

SINGER
9210/9217/9224/9240

LIST OF PARTS

Sewing Machine Models

9210 7057

9217

ALSO

9227

9224

9240

by **SINGER***



A Publication of Product Support
International Group Engineering

Part No. 317161-026

Printed in Taiwan

* A trademark of The Singer Company
Copyright 1993, Singer Sewing Machine Company

All rights reserved throughout the world

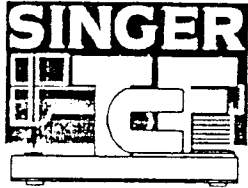

REV _____

REVISION RECORD

REV	DESCRIPTION	APPROVAL AND DATE
1	Page 1 & 2: added item #27 P/N: 179967-456; Page 5 & 6: added item #12 P/N: 286550-900, #13 P/N 286552-451, #14 P/N: 286553-451' #15 P/N: 286716, #16 P/N 286566-451; #1A P/N: 286766-001 change to 286861-001, P/N: 286766-002 change to 286861-002. Page 7 & 8: added item #12, 13, 14, 15 & 16 (same as page 5 & 6). item #1B P/N: 286300-002 change to 286862-002, P/N: 286600-003 change to 286862-003, P/N: 286600-001 change to 286864-001, P/N: 286600-004 change to 286864-004, P/N: 286600-006 chang to 286862-006, P/N: 286600-007 change to 286862-007. P/N: 286600-008 change to 286864-008.	GN92369 12/14/92
2	Page 35 & 36: deleted item #8 P/N: 446138.	GN92356 12/17/92
3	Page 8: deleted P/N: 286864-001 & 286606-900; Added page 37 & 38. Page 4: change P/N: 286529-901 to 286529-001. Page 5: change P/N: 286607-901 to 286607-001. Page 8: change P/N: 286723-901 to 286723-001; chang P/N: 286725-901 to 286725-001; chang P/N: 286728-901 to 286728-901. .Page 1: change P/N: 179967-456 to 179967-461.	GN92354 GN93018 GN93023 03/05/93 GN92110

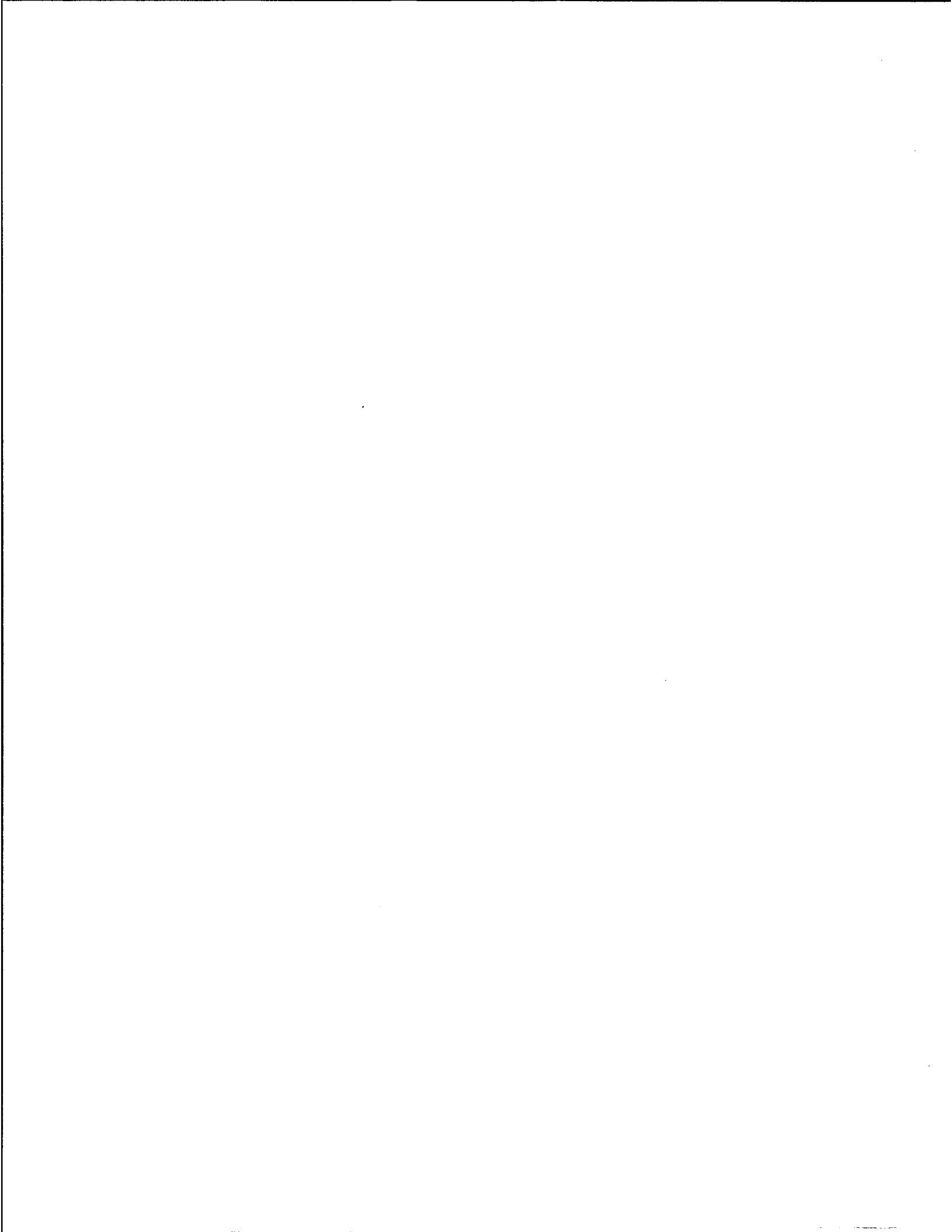

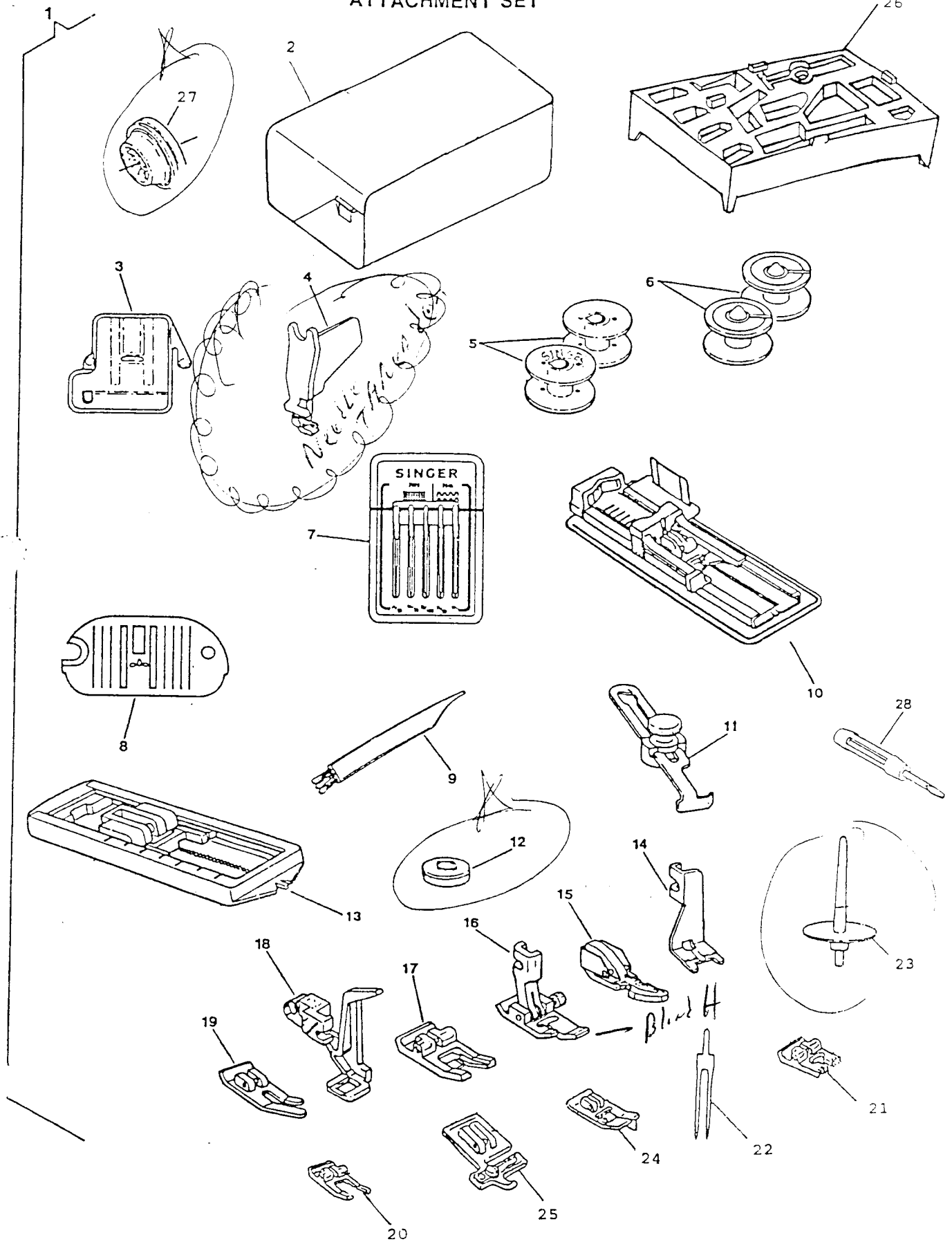

REV. DATE: 03/05/93

COVERS AND ADD ONS PAGE:03

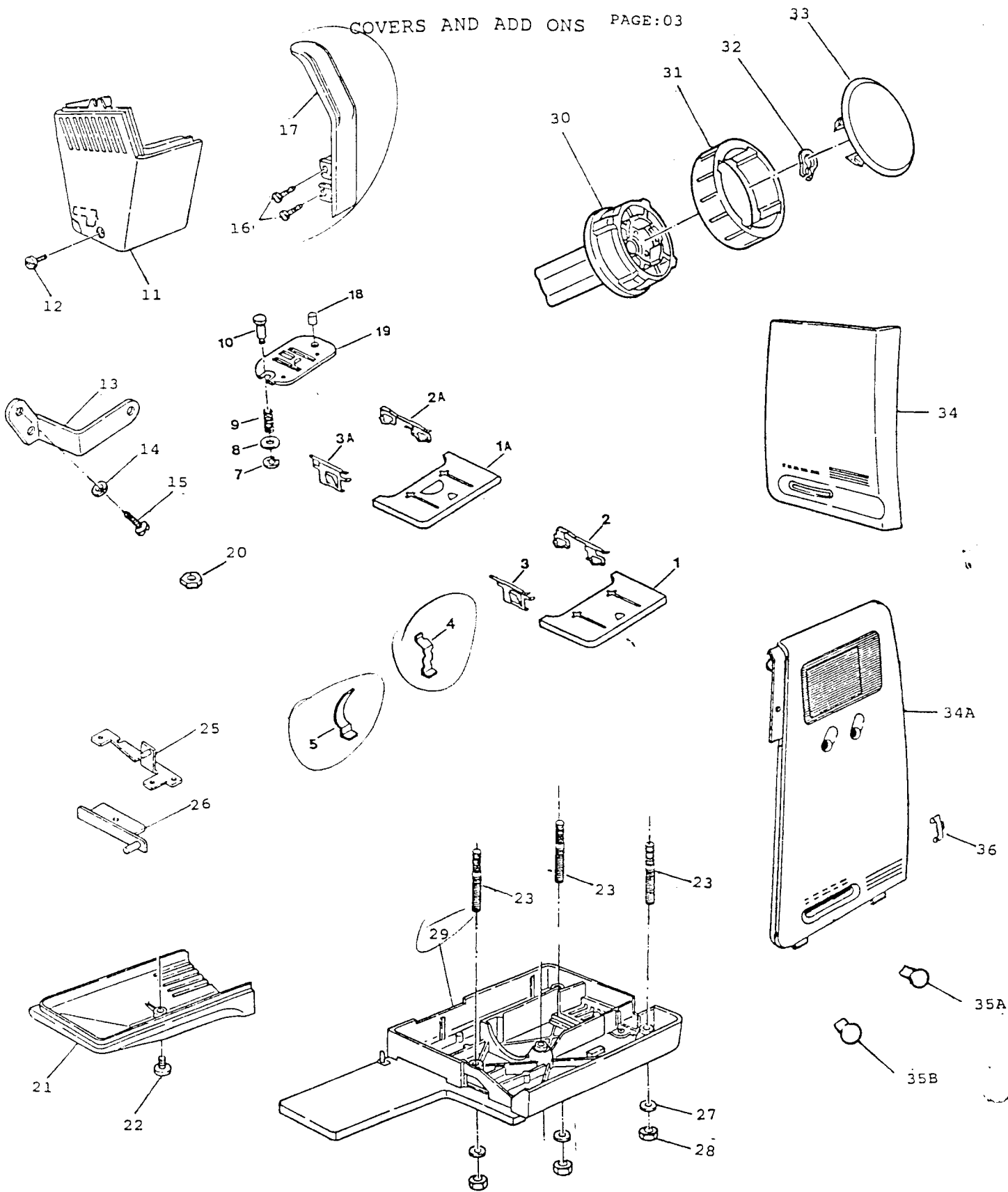

INDEX

PAGE NO.	SUBASSEMBLY
1, 2	ATTACHMENT SET
3, 4	COVERS AND ADD ONS
5, 8	ARM TOP COVER
9, 10	ARM SHAFT DRIVE SYSTEM
11, 12	HAND WHEEL
13, 14	COAXIAL PRESSER BAR SYSTEM
15, 16	NEEDLE BAR & THREAD TAKE-UP
17, 18	ALPHA FEED
19, 20	HOOK SYSTEM (APOLLO)
21, 22	HOOK AND BOBBIN WINDING SYSTEM (CENTAUR)
23, 28	PATTERN, STITCH LENGTH CONTROL & CAM CONTROLLED FEED
29, 30	DEMAND RESPONSIVE NEEDLE TENSION SYSTEM
31, 36	ELECTRICAL EQUIPMENT

ATTACHMENT SET
MODEL: 9210 9217 9224 9240

REF. NO.	PART NO.	DESCRIPTION	9	9	9	9
			9	9	9	9
			2	2	2	2
			1	1	2	4
			0	7	4	0
						X
1	286639-002	ATTACHMENT COMPLETE			X	X
1	286639-001	ATTACHMENT COMPLETE				X
1	286639-003	ATTACHMENT COMPLETE				X
2	286626	ACCESSORY BOX ASS'Y	X	X	X	X
3	313117	FEED COVER PLATE	X	X	X	X
4	503277-454	NEEDLE THREADER COMPLETE				X X X
4	503277-454	NEEDLE THREADER COMPLETE (FOR TAIWAN)	X	X	X	
5	172336	BOBBIN (APOLLO)				X
5	172336-001	BOBBIN (APOLLO)				X
6	312956	ROTATING HOOK BOBBIN ASSEMBLY (TAIWAN)			X	X X X
6	312956-001	BOBBIN (CENTAUR)			X	X X X
7	353364	NEEDLE PACK (ALT:384064)	X	X	X	X
8	313066	THROAT PLATE FOR STRAIGHT SEWING	X	X	X	X
9	546358-453	LINT BRUSH			X	X X X
10	313093-453	BOTTONHOLE PRESSER FOOT (ONE-STEP) COMPLETE			X	X X X
11	161172	SEAM AND BLINDSTITCH HEM GUIDE COMPLETE			X	X X X
12	507664-467	ARM SPOOL PIN THREAD LEAD-OFF (SMALL, PLASTIC)			X	X X X
13	313992-451	PRESSER FOOT PLATE (4-STEPS) FOR SEWING BUTTONHOLES	X			X
14	381066	PRESSER FOOT PLATE FOR BUTTON SEWING			X	X X X
15	171480	PRESSER FOOT PLATE (SNAP-ON) FOR CORDING AND SLIDE FASTENERS	X	X	X	X
		COMPLETE			X	X X X X
16	381491	BLIND HEM PRESSER FOOT ASSEMBLY			X	X X X X
17	171463	SPECIAL PURPOSE PRESSER FOOT PLATE (SNAP-ON)			X	X X X X
18	384037	DARNING AND EMBROIDERY FOOT COMPLETE (PLASTIC)			X	X X X
19	353628	PRESSER FOOT PLATE (SNAP-ON) FOR STRAIGHT SEWING			X	X X X
20	317446	OPEN-TOE EMBROIDERY FOOT				X
21	317263	PINTUCK PRESSER FOOT ASSEMBLY				X
22	N2025-014	TWIN NEEDLE (SIZE 14)				X
23	313026-452	SPOOL PIN (PLASTIC) FOR TWIN NEEDLE SEWING				X
24	541582	OVEREDGE FOOT CPL.				X
25	543106	SHIRring PRESSER FOOT PLATE COMPLETE				X X X
26	286620	TOP TRAY OF ACCESSORY BOX	X	X	X	X
27	179967-461	SPOOL PIN THREAD LEAD-OFF	X	X	X	
28	161295-452	SCREW DRIVER (FOR TAIWAN)	X	X	X	

COVERS AND ADD ONS
 MODEL: 9210 9217 9224 9240

REF. PART NO.	PART NO.	DESCRIPTION	9	9	9	9
			9	9	9	9
			2	2	2	2
			1	1	2	4
			0	7	4	0
1	314666	BED SLIDE ASSEMBLY COMPLETE (APOLLO)				
1A	314109	BED SLIDE ASSEMBLY COMPLETE (ALT:313166)	X			
2	314669	BED SLILDE SPRING (RIGHT)		X	X	X
2A	312779	BED SLIDE SPRING (RIGHT)	X			
3	314670	BED SLIDE SPRING (LEFT)		X	X	X
3A	313108	BED SLIDE SPRING (LEFT)	X			
4	313178	BED SLIDE STOP		X	X	X
5	313179	BED SLIDE STOP SPRING	X			
7	313098	THROAT PLATE PLUNGER RETAINING RING	X			
8	549426-451	THROAT PLATE PLUNGER WASHER	X	X	X	X
9	312805	THROAT PLATE PLUNGER SPRING	X	X	X	X
10	312804	THROAT PLATE PLUNGER	X	X	X	X
11	286610-451	FACE PLATE COMPLETE	X	X	X	X
12	113521-451	FACE PLATE MOUNTING SCREW	X	X	X	X
13	286680	FACE PLATE MOUNTING BRACKER	X	X	X	X
14	446138	FACE PLATE MOUNTING BRACKET SCREW WASHER	X	X	X	X
15	544211-002	FACE PLATE MOUNTING BRACKET SCREW	X	X	X	X
16	113470-003	THREAD TAKE-UP COVER MOUNTING SCREW	X	X	X	X
17	286529-001	THREAD TAKE-UP COVER	X	X	X	X
18	314765	THROAT PLATE LOCATING PIN	X	X	X	X
19	312777	THROAT PLATE FOR ZIG-ZAG SEWING	X	X	X	X
20	313049	BED INSERT NUT	X	X	X	X
21	286505-900	BED COVER (TUBULAR)	X	X	X	X
22	354633-452	BED COVER (TUBULAR)SCREW	X	X	X	X
23	286509-451	BASE COVER MOUNTING BOLT	X	X	X	X
25	286510	HANDLE HINGE BRACKET ASSEMBLY (RIGHT)	X	X	X	X
26	286513	HANDLE HINGE BRACKET ASSEMBLY (LEFT)	X	X	X	X
27	314712-451	BOTTOM COVER MOUNTING BOLT WASHER	X	X	X	X
28	313177-451	BOTTOM COVER MOUNTING BOLT MOUNTING NUT	X	X	X	X
29	286539-001	BASE PLATE ASSEMBLY	X	X	X	X
30	286555-900	PATTERN SELECTOR KNOB	X	X	X	X
31	286561	RING, PATTERN SELECTOR KNOB	X	X	X	X
32	543855-006	RETAINING RING, PATTERN SELECTOR KNOB	X	X	X	X
33	286562	PATTERN SELECTOR KNOB CAP	X	X	X	X
34	286538-001	STITCH LENGTH PANEL W/GRAPHICS	X	X	X	X
34	286538-002	STITCH LENGTH PANEL W/GRAPHICS (CONCERTO)	X	X	X	X
34A	286733	STITCH LENGTH PANEL W/GRAPHICS	X	X	X	X
35A	286548-451	BIGHT AMPLITUDE CONTROL LEVER & STITCH LENGTH CONTROL LEVER KNOB	X	X	X	X
35B	286524-451	THREAD TENSION KNOB	X	X	X	X
36	286858-451	STUFFING, LCD LANGUAGE SELECTION				X

ARM TOP COVER
MODEL: 9210 9217 9224 9240

REF. PART NO.	DESCRIPTION	9	9	9
1A	286861-001 ARM TOP COVER ASSEMBLY WITH HANDLE			X
1A	286861-002 ARM TOP COVER ASSEMBLY WITH HANDLE (CONCERTO 1)			X
2A	286607-001 CONTROL PANEL WITH GRAPHICS			X
3A	286605-901 CONTROL PANEL EXTENSION WITH GRAPHICS			X
3A	286605-906 CONTROL PANEL EXTENSION WITH GRAPHICS (EUROPE)			X
4	286614 BOBBIN WINDER ASSEMBLY			X
5	286793 BOBBIN WINDER LEVER SPRING			X
6	312613 BOBBIN WINDER LEVER HINGE SCREW SHOULDER WASHER			X
7	354927-004 BOBBIN WINDER LEVER HINGE SCREW			X
8	502495-451 WASHER, CONTROL PANEL EXTENSION & CONTROL PANEL MOUNTING SCREW			X
9	113455-003 SCREW, CONTROL PANEL EXTENSION MOUNTING			X
11	113455-001 SCREW, CONTROL PANEL MOUNTING			X
12	286550-900 ARM TOP COVER LID			X
13	286552-451 ARM TOP COVER LID HINGE (LEFT)			X
14	286553-451 ARM TOP COVER LID HINGE (RIGHT)			X
15	286716 MACHINE HANDLE			X
16	286566-451 SPOOL PIN			X

NOT FOR
TWIN
NEEDLE

A TC

REV. DATE: 03/05/93

ARM TOP COVER

PAGE:06.

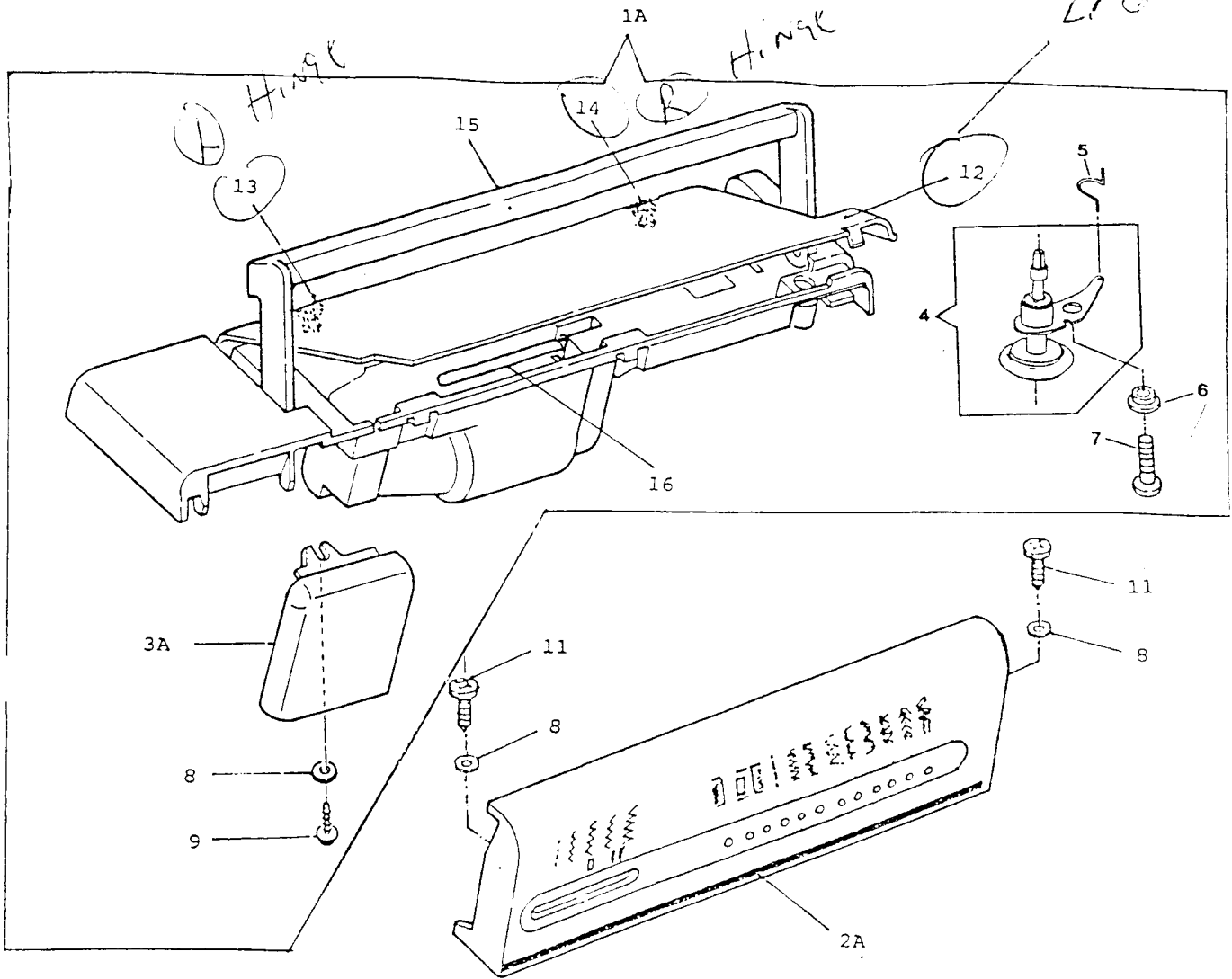

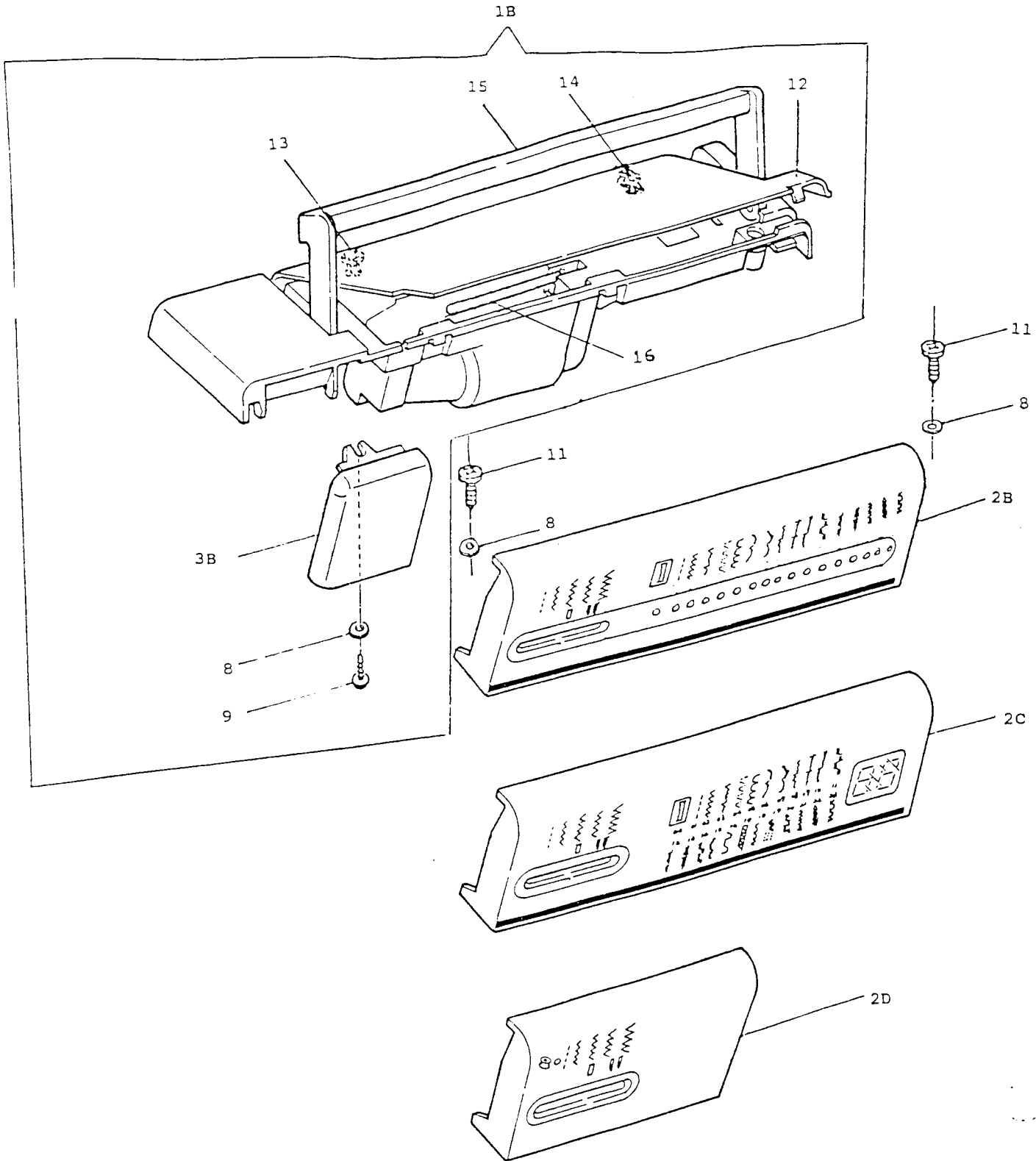

ARM TOP COVER (CONT.)
 MODEL: 9210 9217 9224 9240

9 9 9 9
 2 2 2 2
 1 1 2 4
 0 7 4 0

REF. PART NO.	PART NO.	DESCRIPTION				
1B	286862-002	ARM TOP COVER ASSEMBLY WITH HANDLE		X		
1B	286862-003	ARM TOP COVER ASSEMBLY WITH HANDLE			X	
1B	286862-006	ARM TOP COVER ASSEMBLY WITH HANDLE (CONCERTO 2)		X		
1B	286862-007	ARM TOP COVER ASSEMBLY WITH HANDLE (CONCERTO 3)			X	
1B	286864-008	ARM TOP COVER ASSEMBLY WITH HANDLE (CONCERTO 4)				X
1B	286864-004	ARM TOP COVER ASSEMBLY WITH HANDLE (QUANTUM)				X
2B	286723-001	CONTROL PANEL WITH GRAPHICS		X		
2C	286725-001	CONTROL PANEL WITH GRAPHICS			X	
2D	286728-001	CONTROL PANEL WITH GRAPHICS				X
3B	286605-902	CONTROL PANEL EXTENSION WITH GRAPHICS		X		
3B	286605-903	CONTROL PANEL EXTENSION WITH GRAPHICS			X	
3B	286605-904	CONTROL PANEL EXTENSION WITH GRAPHICS (QUANTUM)				X
3B	286605-907	CONTROL PANEL EXTENSION WITH GRAPHICS (CONCERTO 2)		X		
3B	286605-908	CONTROL PANEL EXTENSION WITH GRAPHICS (CONCERTO 3)			X	
3B	286605-909	CONTROL PANEL EXTENSION WITH GRAPHICS (CONCERTO 4)				X
8	502495-451	WASHER, CONTROL PANEL EXTENSION & CONTROL PANEL MOUNTING SCREW		X	X	X
9	113455-003	SCREW, CONTROL PANEL EXTENSION MOUNTING		X	X	X
11	113455-001	SCREW, CONTROL PANEL MOUNTING		X	X	X
12	286550-900	ARM TOP COVER LID		X	X	
12	286839	ARM TOP COVER LID				X
13	286552-451	ARM TOP COVER LID HINGE (LEFT)		X	X	X
14	286553-451	ARM TOP COVER LID HINGE (RIGHT)		X	X	X
15	286716	MACHINE HANDLE		X	X	X
16	286566-451	SPOOL PIN		X	X	X

ATC Threadguide
 part # 353553451
 pu Bob
 CA NPS

ARM SHAFT DRIVE SYSTEM
 MODEL: 9210 9217 9224 9240

REF. PART NO.	PART NO.	DESCRIPTION	9	9	9	9
			9	9	9	9
			2	2	2	2
			1	1	2	4
			0	7	4	0
1	113455-001	ARM SHAFT (HORIZONTAL) BUSHING (LEFT & RIGHT) CLAMP SCREW	X			
1	113455-002	ARM SHAFT (HORIZONTAL) BUSHING (LEFT &RIGHT) CLAMP SCREW	X	X	X	X
2	312796-451	ARM SHAFT BUSHING CLAMP	X	X		
2	312796-452	ARM SHAFT BUSHING CLAMP			X	X
3	286580-001	ARM SHAFT ASSEMBLY (APOLLO)	X			
3A	286580-002	ARM SHAFT ASSEMBLY (CENTAUR)		X	X	X
4	603975-011	BELT (ROTATING HOOK DRIVE) ALT:603975-012	X	X	X	X
5	313195	IDLER BRACKET ASSEMBLY	X	X	X	X
6	314041-451	ROTATING HOOK DRIVING BELT TENSION ADJUSTER SCREW WASHER	X	X	X	X
7	113455-002	ROTATING HOOK DRIVING BELT TENSION ADJUSTER SCREW	X	X	X	X
8	286824	GROUNDING LEAD ASS'Y			X	X
9	314010	ROTATING HOOK DRIVE SHAFT SUB-ASSEMBLY	X	X	X	X
10	313816	ROTATING HOOK DRIVE SHAFT BUSHING (SELF-ALIGNING) CLAMP	X	X		
10	313184-001	ROTATING HOOK DRIVE SHAFT BUSHING (SELF ALIGNING) CLAMP			X	X
11	314013-451	ARM SHAFT BUSHING CLAMP WASHER		X	X	X
12	314013-451	ROTATING HOOK DRIVE SHAFT BUSHING CLAMP SCREW LOCK WASHER	X	X	X	X
13	113455-003	SCREW, CABLE TIE MOUNTING	X	X	X	X
14	604690-001	SELF LOCKING NYLON CABLE TIE	X	X	X	X

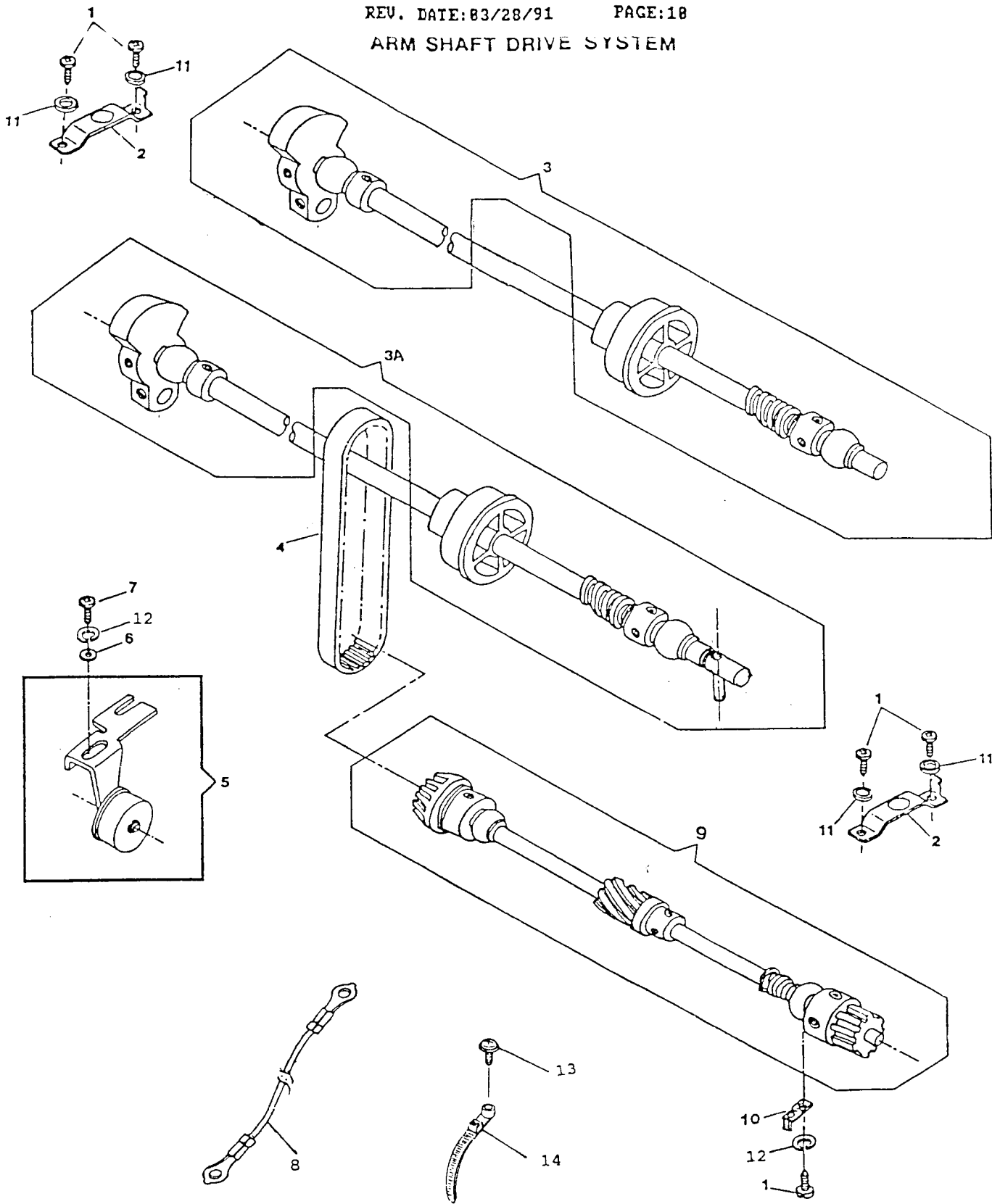

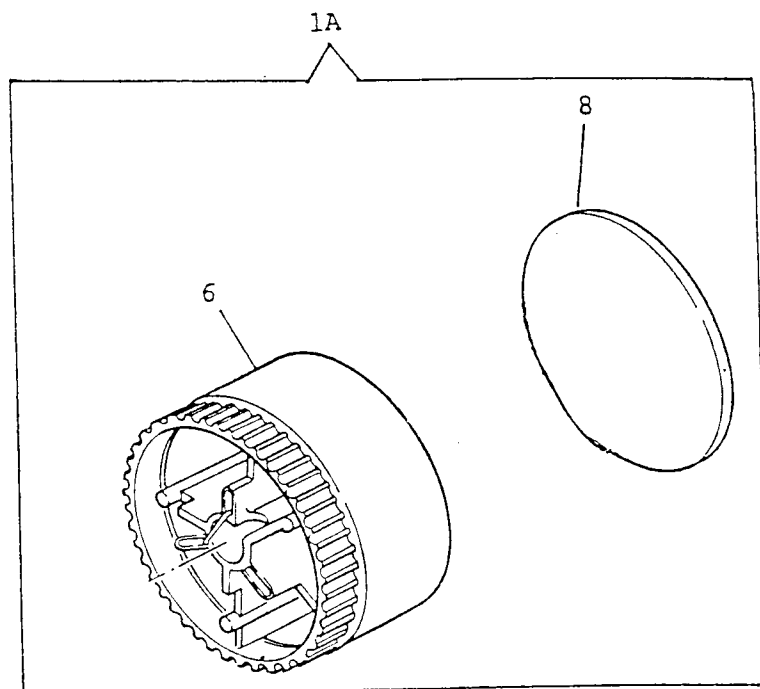
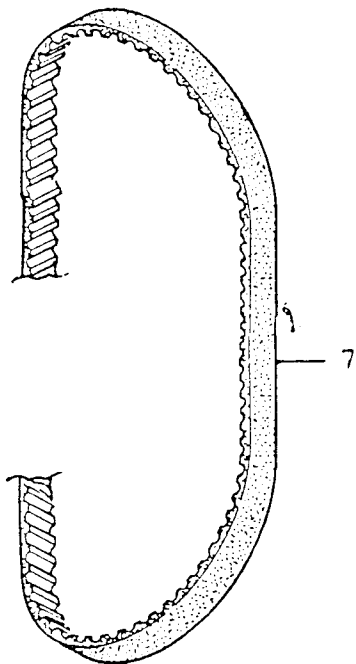
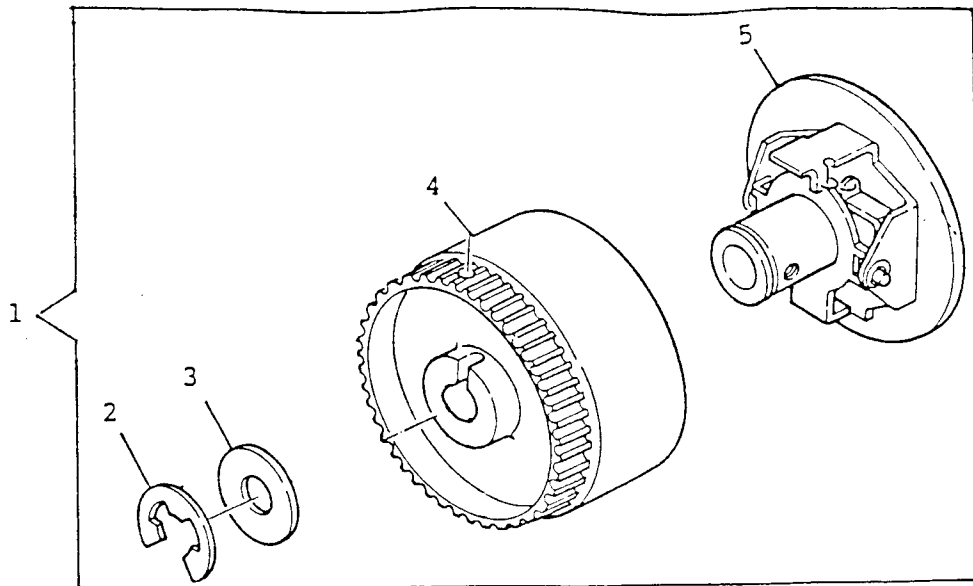

HAND WHEEL
 MODEL: 9210 9217 9224 9240

REF. PART NO.	PART NO.	DESCRIPTION	9	9	9	9
			2	2	2	2
			1	1	2	4
			0	7	4	0
1	286589-001	HAND WHEEL ASSEMBLY	X			
1A	286831-001	HAND WHEEL ASSEMBLY		X	X	X
2	286595-451	HAND WHEEL DISENGAGING CLUTCH BUSHING RETAINING RING	X			
3	286596-451	HAND WHEEL DISENGAGING CLUTCH BUSHING PLASTIC WASHER	X			
4	286590-451	HAND WHEEL (PLASTIC)	X			
5	286586-451	HAND WHEEL DISENGAGING CLUTCH MECH. COMP.	X			
6	286719	HAND WHEEL SPRING SUB-ASS'Y		X	X	X
7	312628-001	BELT (MOTOR DRIVE)	X	X	X	X
8	286692-451	HAND WHEEL COVER PLATE		X	X	X

COAXIAL PRESSER BAR SYSTEM FOR NEW HEAD END
 MODEL: 9210 9217 9224 9240

REF. PART NO.	DESCRIPTION	9	9	9	9
		2	2	2	2
		1	1	2	4
		0	7	4	0
1	314695-002 HEAD END MODULE (APOLLO)	X			
1	314700-005 HEAD END MODULE (CENTAUR)		X	X	
1A	286672 HEAD END MODULE (CENTAUR)				X
2	286784 FACE PLATE MOUNTING BRACKET	X	X	X	X
3	313955-451 HEAD END MOUNTING PLATE LOCK WASHER	X	X	X	X
4	113455-012 HEAD END MOUNTING PLATE SCREW	X	X	X	
5	163706-451 PRESSER FOOT SHANK (SNAP-ON)				X
5	370502-001 PRESSER FOOT SHANK (SNAP-ON)	X	X	X	X
6	313150 PRESSER FOOT PLATE (SNAP-ON) FOR ZIG-ZAG SEWING	X			
7A	113531-451 PRESSER FOOT THUMB SCREW				X
7B	314627-451 PRESSER FOOT THUMB SCREW & BOBBIN WINDER THREAD HOLDER		X	X	
7C	286677-451 PRESSER FOOT THUMB SCREW & BOBBIN WINDER THREAD HOLDER				X
	ASS'Y				
8	286681-001 NEEDLE THREADER COMPLETE				X
9	113455-001 NEEDLE THREAD TENSION RELEASE LEVER HINGE SCREW	X	X	X	X
10	314041-451 NEEDLE THREAD TENSION RELEASE LEVER RETAINING WASHER	X	X	X	X
11	314589 NEEDLE THREAD TENSION RELEASE LEVER ASSEMBLY	X	X	X	X
12	N2020-014 NEEDLE (SIZE NO.14, IN MACHINE)	X	X	X	X
13	113408-001 NEEDLE BAR DRIVING ARM BALL JOINT SCREW	X	X	X	X
14	931929-004 NEEDLE BAR DRIVING ARM BALL JOINT SCREW WASHER	X	X	X	X
15	314690 THREAD PINCH PLATE	X	X	X	X

COAXIAL PRESSER BAR SYSTEM FOR NEW HEAD END

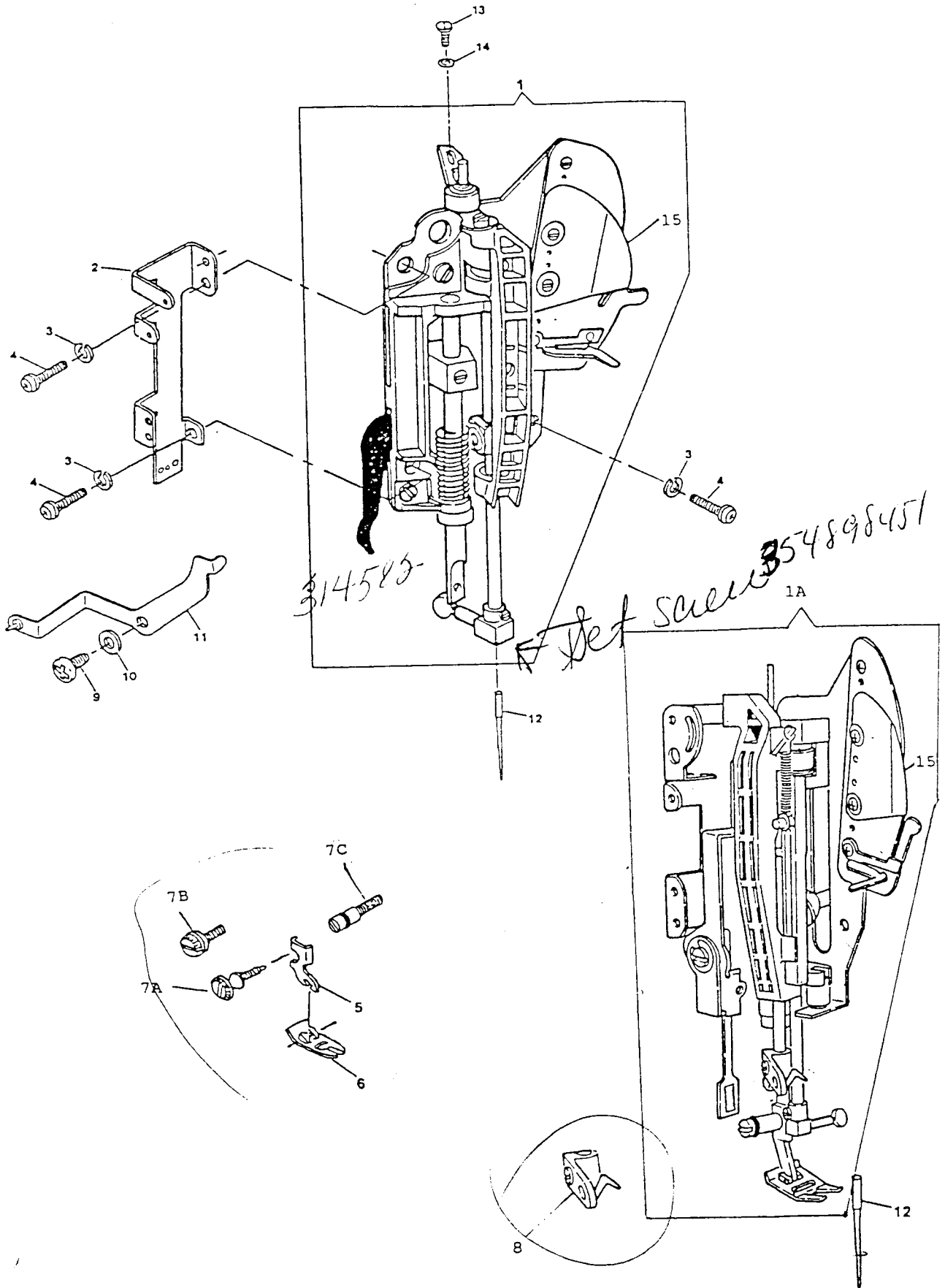

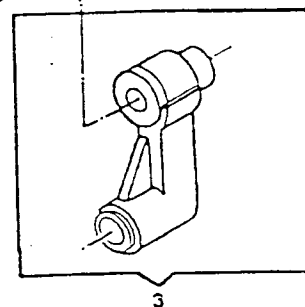
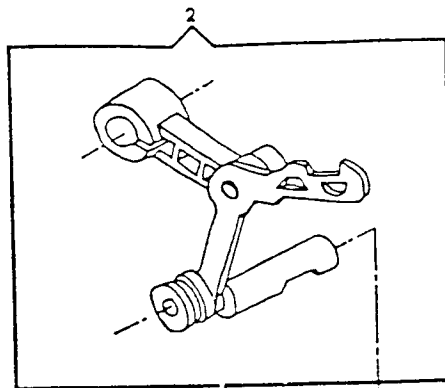
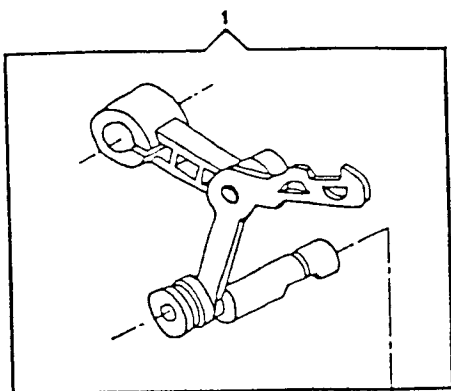

NEEDLE BAR & THREAD TAKE-UP FOR NEW HEAD END
 MODEL: 9210 9217 9224 9240

REF. PART NO.	PART NO.	DESCRIPTION	9	9	9	9
			2	2	2	2
			1	1	2	4
			0	7	4	0
1	314694	THREAD TAKE-UP COMPLETE (APOLLO)				X
2	314699	THREAD TAKE-UP COMPLETE (CENTAUR)			X	X X X
3	137528-901	NEEDLE BAR CONNECTING LINK ASSEMBLY			X	X X X X

ALPHA FEED
 MODEL: 9210 9217 9224 9240

REF. PART NO.	DESCRIPTION	9	9	9	9
		9	9	9	9
		2	2	2	2
		1	1	2	4
		0	7	4	0
1	141920-452 FEED DOG MOUNTING SCREW	X	X	X	X
2	313021 FEED DOG (ZINC) (CENTAUR)	X	X	X	
2A	312679 FEED DOG (APOLLO) ALT:313171	X			
3	314140-002 ALPHA FEED MODULE (APOLLO)		X	X	X
3	314140-001 ALPHA FEED MODULE (CENTAUR)	X	X	X	X
4	312851 FEED BAR PIVOT HINGE STUD CLAMP	X	X	X	X
5	113455-003 SCREW, FEED BAR PIVOT HINGE STUD CLAMP	X	X	X	X
6	314141 FEED BAR ASSEMBLY	X	X	X	X
7	354921-451 FEED & ROTATING HOOK DRIVE SHAFT BEARING BLOCK SCREW	X	X	X	X
8	314070 ROTATING HOOK DRIVE SHAFT BUSHING SPRING	X	X	X	X
9	514674-451 FEED & ROTATING HOOK DRIVE SHAFT BEARING BLOCK MOUNTING	X	X	X	X
	SCREW NUT	X	X	X	X
10	286817 FEED REGULATOR SHAFT BUSHING CLAMP	X	X	X	X
11	313133 FEED REGULATOR SHAFT ASSEMBLY	X	X	X	X
12	313816 FEED REGULATOR SHAFT BUSHING CLAMP	X	X	X	X
13	314013-451 FEED REGULATOR SHAFT BUSHING CLAMP SCREW LOCK WASHER	X	X	X	X
14	113455-001 FEED REGULATOR SHAFT BUSHING CLAMP SCREW	X	X	X	X
15	511030 FEED REGULATOR SLIDE BLOCK		X	X	
16	317479-001 GROUNDING LEAD ASSEMBLY (R/H DRIVE)		X	X	
17	313852 ROTATING HOOK GROUNDING CLIP		X	X	
18	317470-001 GROUNDING LEAD ASSEMBLY (ROTATING HOOK)		X	X	
19	113455-001 SCREW, ROTATING HOOK GROUNDING CLIP		X	X	

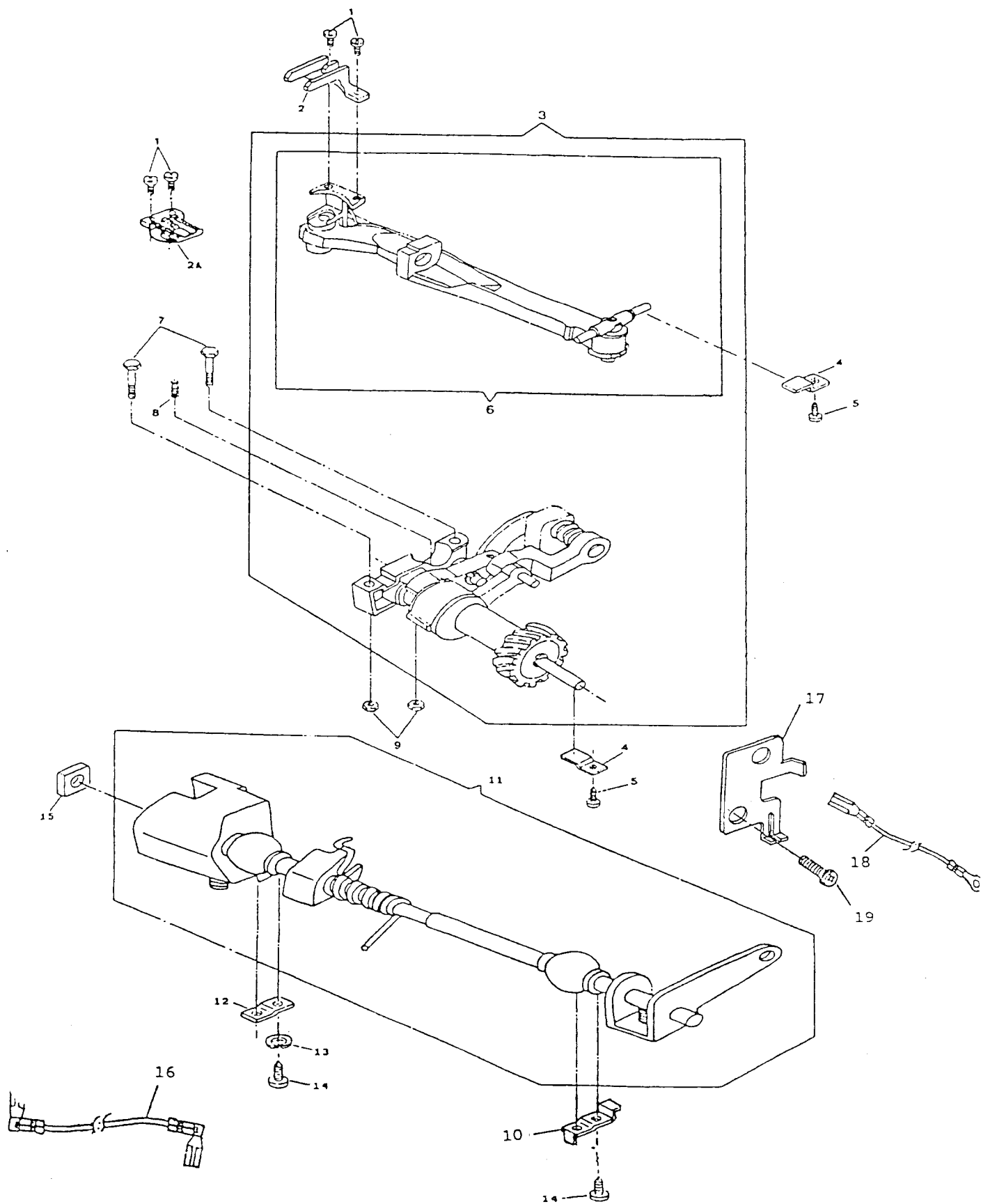

HOOK SYSTEM (APOLLO)

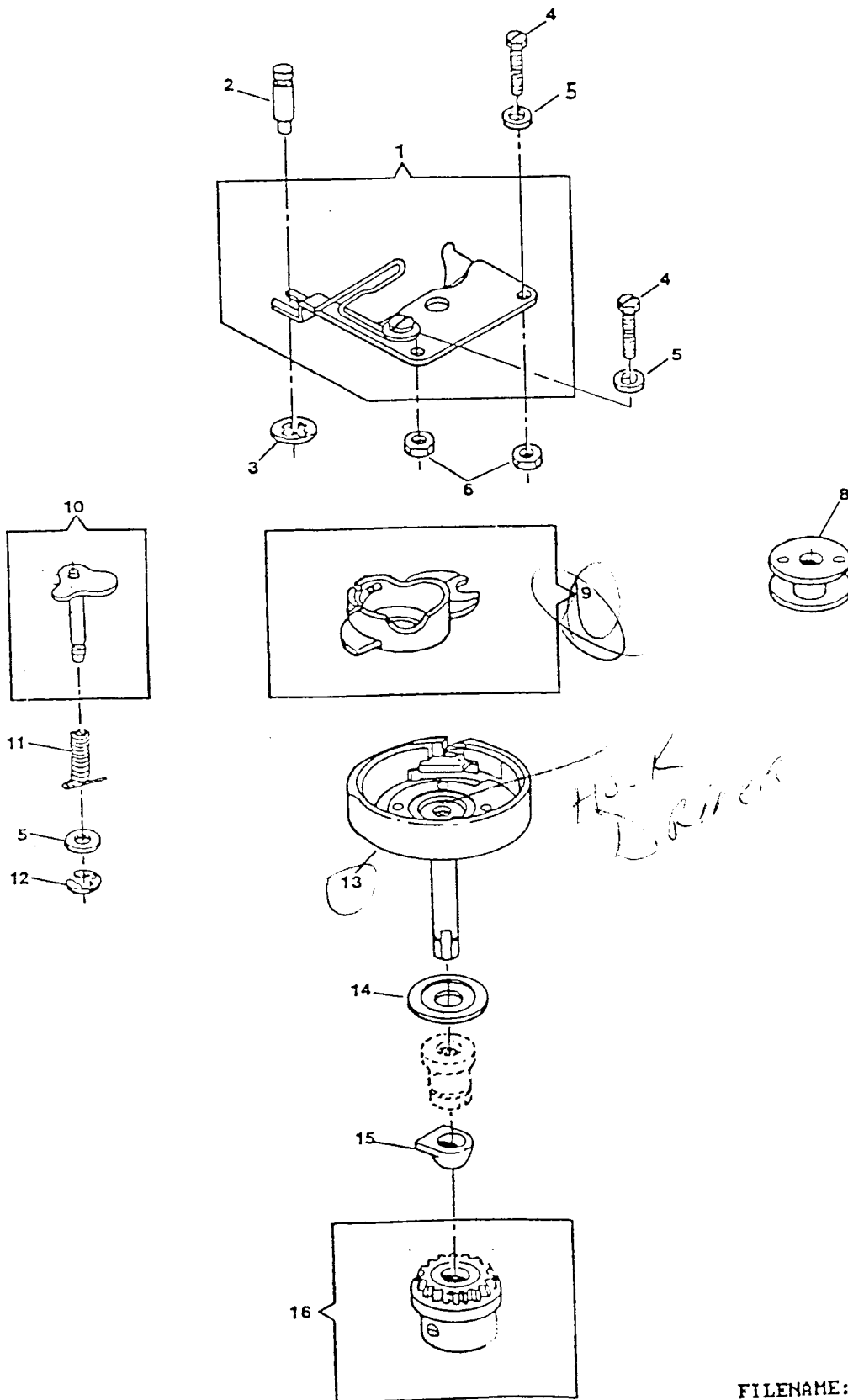

HOOK SYSTEM (APOLLO)
 MODEL: 9210 9217 9224 9240

REF. NO.	PART NO.	DESCRIPTION	9	9	9	9
1	313089	ROTATING HOOK BOBBIN CASE POSITION PLATE ASSEMBLY				X
2	312603	ROTATING HOOK BOBBIN CASE POSITION PLATE HOLD DOWN STUD				X
3	313161	ROTATING HOOK BOBBIN CASE POSITION PLATE HOLD DOWN STUD RETAINER				X
4	113439-451	ROTATING HOOK BOBBIN CASE POSITION PLATE SCREW				X
5	313190-451	ROTATING HOOK BOBBIN CASE POSITION PLATE SCREW WASHER				X
6	313945-451	ROTATING HOOK BOBBIN CASE POSITION PLATE SCREW NUT				X
8	172336	ROTATING HOOK BOBBIN (PLASTIC)				X
8	172336-001	ROTATING HOOK BOBBIN (PLASTIC)				X
9	421325-451	ROTATING HOOK BOBBIN CASE COMPLETE <i>aplo</i>				X
10	312846	ROTATING HOOK BOBBIN CASE RETAINING PLATE SUB-ASSEMBLY				X
11	312607	ROTATING HOOK BOBBIN CASE RETAINING PLATE STUD SPRING				X
12	313783	ROTATING HOOK BOBBIN CASE RETAINING PLATE STUD RETAINING RING				X
13	447926-932	ROTATING HOOK COMPLETE				X
14	314049-001	ROTATING HOOK FLANGED BUSHING THRUST WASHER				X
15	312847	ROTATING HOOK FLANGED BUSHING WASHER				X
16	314012	ROTATING HOOK BEVEL GEAR COMPLETE				X

HOOK AND BOBBIN WINDING SYSTEM (CENTAUR)
 MODEL: 9210 9217 9224 9240

REF. NO.	PART NO.	DESCRIPTION	9	9	9	9
			9	9	9	9
			2	2	2	2
			1	1	2	4
			0	7	4	0
1	312956-001	BOBBIN			X	X X
2	314662-001	ROTATING HOOK BOBBIN CASE COMPLETE				X
2	314662-002	ROTATING HOOK BOBBIN CASE COMPLETE			X	X
3	313183-002	ROTATING HOOK ASSEMBLY			X	X X
4	314049-001	ROTATING HOOK FLANGED BUSHING THRUST WASHER			X	X X
5	312847	ROTATING HOOK FLANGED BUSHING WASHER			X	X X
6	314012	ROTATING HOOK BEVEL GEAR COMPLETE			X	X X
7	313956	BED SLIDE ACTUATING LEVER ASSEMBLY			X	X X
8	354929-451	BED SLIDE ACTUATING LEVER STUD SCREW			X	X X
9	113439-451	ROTATING HOOK BOBBIN CASE POSITION PLATE SCREW			X	X X
10	312738	ROTATING HOOK BOBBIN CASE POSITION PLATE			X	X X
11	313190-451	ROTATING HOOK BOBBIN CASE POSITION PLATE SCREW WASHER			X	X X
12	313945-451	ROTATING HOOK BOBBIN CASE POSITION PLATE SCREW NUT			X	X X
13	313088	ROTATING HOOK BOBBIN CASE RETAINING PLATE COMPLETE			X	X X
14	313930	ROTATING HOOK BOBBIN CASE RETAINING PLATE RETURN SPRING			X	X X
15	314072	ROTATING HOOK BOBBIN CASE RETAINING PLATE SPRING			X	X X
16	312702	ROTATING HOOK BOBBIN CASE RETAINING PLATE SPRING RETAINING RING			X	X X
17	314766	BED SLIDE STOP PIN			X	X X
18	314768	BED SLIDE STOP PIN RETAINING RING			X	X X
19	314767	BED SLIDE STOP PIN SPRING			X	X X
20	113455-006	SCREW, BED SLIDE STOP PIN			X	X X

REV. DATE: 9/12/91 PAGE: 22
HOOK AND BOBBIN WINDING SYSTEM (CENTAUR)

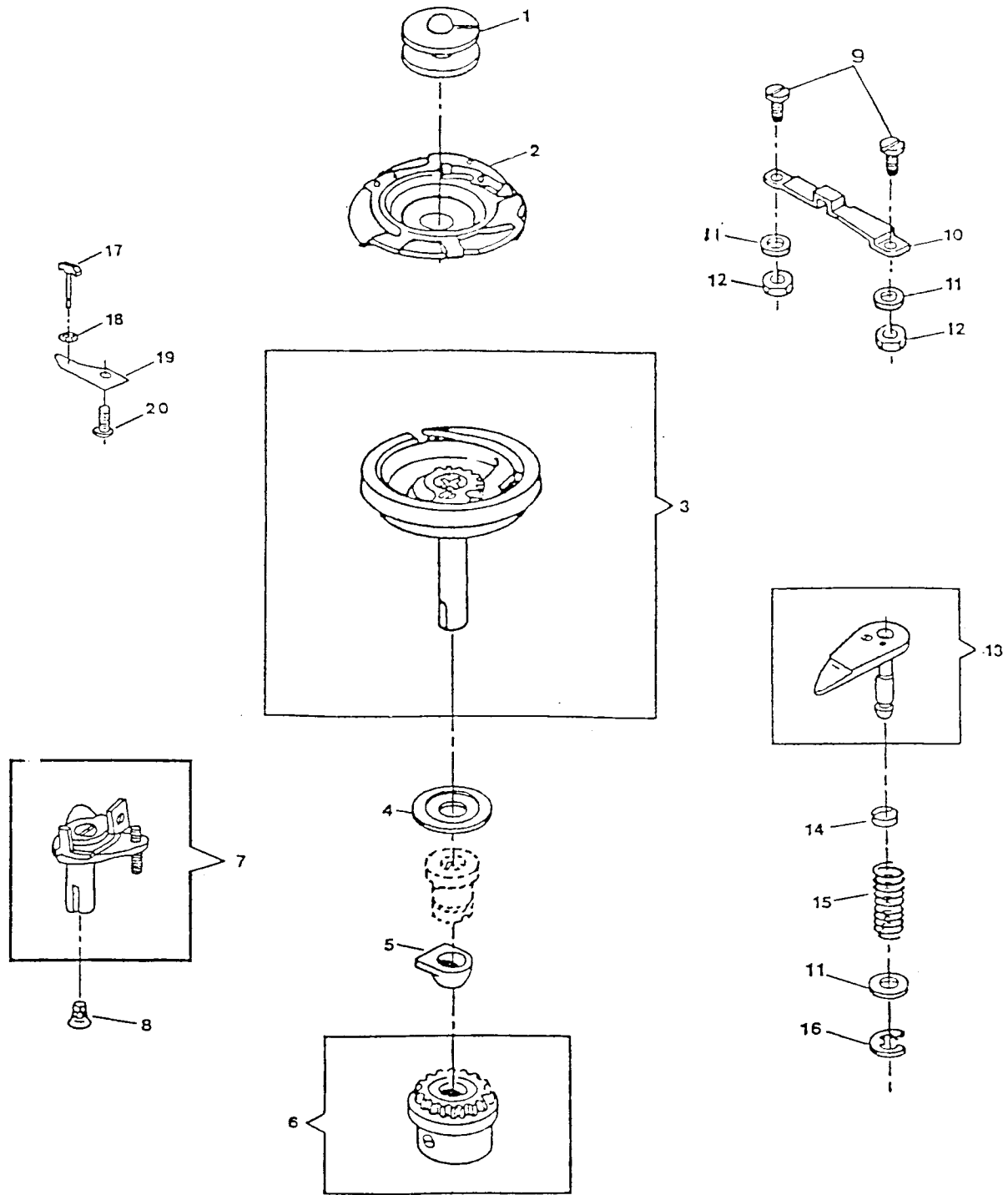

HOOK AND BOBBIN WINDING SYSTEM

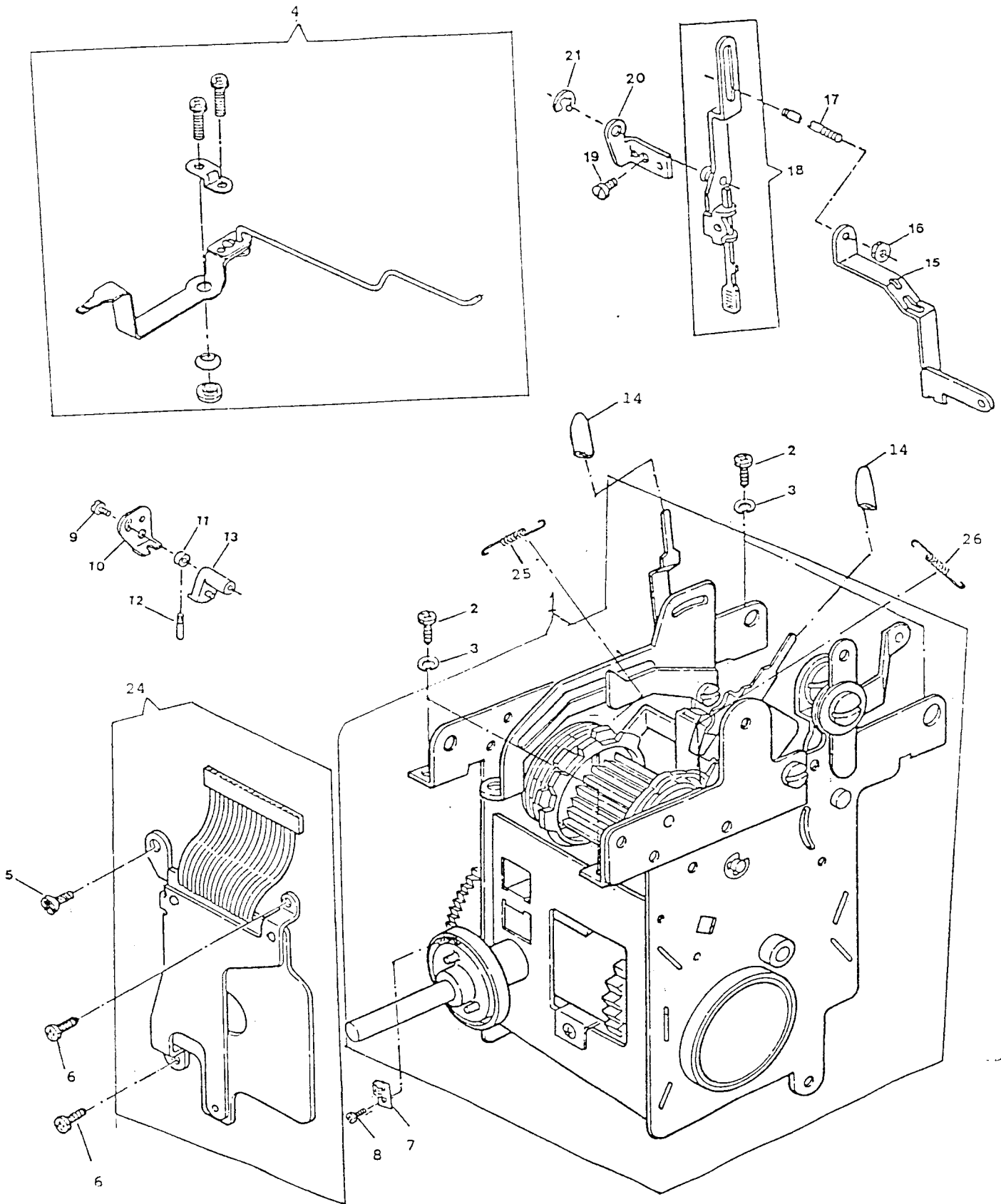

HOOK AND BOBBIN WINDING SYSTEM (APOLLO)
MODEL: 9210 9217

REF. NO.	PART NO.	DESCRIPTION	9	9
			2	2
			1	1
			0	7
1	286630-001	PATTERN SELECTOR MODULE	X	
1	286833-001	PATTERN SELECTOR MODULE		X
2	113455-001	DISC SELECTOR MECHANISM MOUNTING PLATE SCREW (LEFT & RIGHT)	X	X
3	314013-451	DISC SELECTOR MECHANISM MOUNTING PLATE SCREW (LEFT & RIGHT) LOCK WASHER	X	X
4	286738-001	BIGHT AMPLITUDE CONTROL LEVER ASSEMBLY	X	X
5	544212-006	SCREW	X	X
6	354935-451	SCREW	X	X
7	286691	PATTERN SELECTOR CONTACT PLATE	X	X
8	544251	SCREW	X	X
9	544211-010	BUTTONHOLE ACTUATOR CAM ADJUSTING BRACKET SCREW		X
10	313073	BUTTONHOLE ACTUATOR CAM ADJUSTING BRACKET		X
11	313022	BUTTONHOLE FOLLOWER HUB RELEASE		X
12	313023	BUTTONHOLE FOLLOWER HUB RELEASE PIN		X
13	313025	BUTTONHOLE ACTUATOR CAM		X
14	370533-451	NEEDLE POSITION CONTROL LEVER & STITCH BALANCE CONTROL LEVER KNOB	X	X
15	313005	BUTTONHOLE DISC CONTROL CATCH RELEASE LINK		X
16	314763-451	BUTTONHOLE TRIPPING ROD ADJUSTING AND LOCKING NUT		X
17	312982	BUTTONHOLE TRIPPING LEVER ROD		X
18	286789	BUTTONHOLE KICK-OUT SHAFT TRIPPING ROD SUB-ASSY		X
19	354877-451	BUTTONHOLE PIVOT LEVER SCREW		X
20	286782	BUTTONHOLE LEVER PIVOT		X
21	312685	BUTTONHOLE KICK-OUT SHAFT TRIPPING ROD RETAINING RING		X
24	286740-001	<u>PATTERN SELECTOR P.C. BOARD ASSEMBLY</u>	X	
24	286740-002	PATTERN SELECTOR P.C. BOARD ASSEMBLY		X
25	313799	BUTTONHOLE ACTUATOR ADJUSTING ROD SPRING		X
26	314497	NEEDLE BAR DRIVING ARM SLIDE POSITION SPRING	X	X

PATTERN, STITCH LENGTH CONTROL & CAM CONTROLLED FEED (CONT.)
MODEL: 9224 9240

REF. PART NO.	PART NO.	DESCRIPTION	9	9
			2	2
			2	4
			4	0
			X	
1	286834-001	PATTERN SELECTOR MODULE		X
1	286835-001	PATTERN SELECTOR MODULE		X
2	113455-001	DISC SELECTOR MECHANISM MOUNTING PLATE SCREW(LEFT AND RIGHT)	X	X
3	314013-451	DISC SELECTOR MECHANISM MOUNTING PLATE SCREW (LEFT & RIGHT) LOCK WASHER	X	X
4	286738-001	BIGHT AMPLITUDE CONTROL LEVER ASSEMBLY	X	
4	286738-002	BIGHT AMPLITUDE CONTROL LEVER ASSEMBLY		X
5	544211-001	SCREW	X	X
6	317253-001	ROTARY SWITCH ASSEMBLY COMPLETE	X	X
7	314497	NEEDLE BAR DRIVING ARM SLIDE POSITIONING SPRING	X	X
8	286769	BUTTONHOLE KICK-OUT SHAFT TRIP		X
9	544211-010	BUTTONHOLE ACTUATOR CAM ADJUSTING BRACKET SCREW	X	X
10	313073	BUTTONHOLE ACTUATOR CAM ADJUSTING BRACKET	X	X
11	313022	BUTTONHOLE FOLLOWER HUB RELEASE	X	X
12	313023	BUTTONHOLE FOLLOWER HUB RELEASE PIN	X	X
13	313025	BUTTONHOLE ACTUATOR CAM	X	X
14	370533-451	NEEDLE POSITION CONTROL LEVER & STITCH BALANCE CONTROL LEVER KNOB	X	
15	313005	BUTTONHOLE DISC CONTROL CATCH RELEASE LINK	X	X
16	314763-451	BUTTONHOLE TRIPPING ROD ADJUSTING AND LOCKING NUT	X	X
17	312982	BUTTONHOLE TRIPPING LEVER ROD	X	X
18	286789	BUTTONHOLE KICK-OUT SHAFT TRIPPING ROD SUB-ASSEMBLY	X	
19	354877-451	BUTTONHOLE PIVOT LEVER SCREW	X	X
20	286782	BUTTONHOLE LEVER PIVOT	X	X
21	312685	BUTTONHOLE KICK-OUT SHAFT TRIPPING ROD RETAINING RING	X	X
23	317340	SELF-ADHESIVE WIRE CLIP (FC-1)	X	X
25	313799	BUTTONHOLE ACTUATOR ADJUSTING ROD SPRING	X	X

PATTERN, STITCH LENGTH CONTROL & CAM CONTROLLED FEED (CONT.)

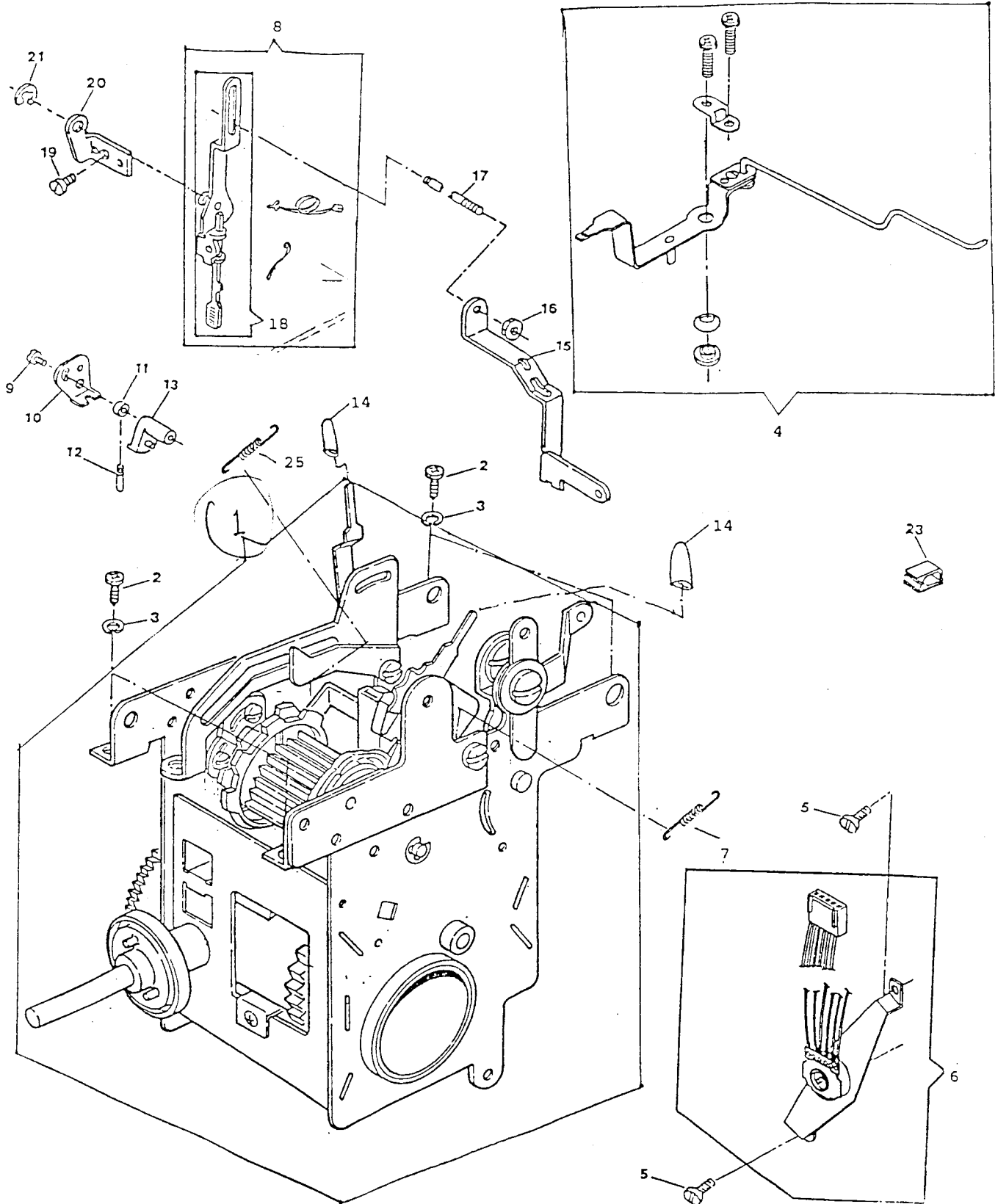

Feed
Reverse
Lever

REV. DATE: 01/13/93 PAGE: 27

PATTERN, STITCH LENGTH CONTROL & CAM CONTROLLED FEED (CONT.)

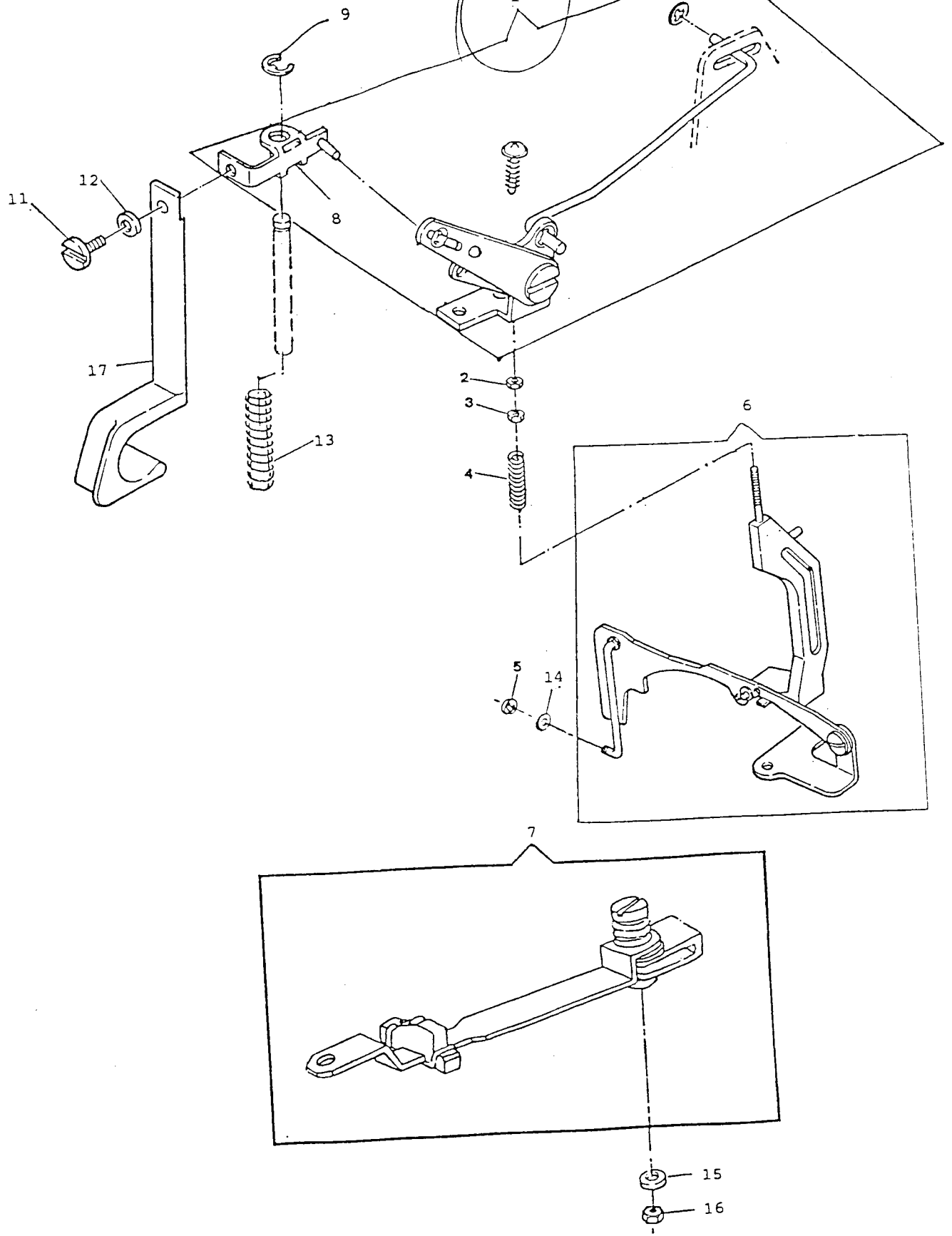

PATTERN, STITCH LENGTH CONTROL & CAM CONTROLLED FEED (CONT.)
 MODEL: 9210 9217 9224 9240

REF. PART NO.	NO.	DESCRIPTION	9	9	9	9
			2	2	2	2
			1	1	2	4
			0	7	4	0
1	286739	REVERSE FEED CONTROL LEVER ASSEMBLY	X	X	X	X
2	514674-451	CAM CONTROLLER FEED CONNECTING ROD LOCKING NUT	X	X	X	X
3	312645-451	CAM CONTROLLER FEED DISC FOLLOWER ACTUATOR CONNECTING ROD ADJUSTING NUT	X	X	X	X
4	313143	CAM CONTROLLED FEED DISC FOLLOWER ACTUATOR CONNECTING ROD SPRING	X	X	X	X
5	312702	CAM CONTROLLED FEED LEVER CONNECTING LINK RETAINING RING	X	X	X	X
6	286597-001	REVERAE FEED MACHINISM	X	X	X	X
7	286598-001	STITCH LENGTH CONTROL LEVER ASSEMBLY	X	X	X	
7	286598-002	STITCH LENGTH CONTROL LEVER ASSEMBLY				X
8	286710	REVERSE FEED CONTROL LEVER CONNECTING PLATE ASSEMBLY	X	X	X	X
9	312686	RETAINING RING, REVERSE FEED CONTROL LEVER CONNECTING PLATE	X	X	X	X
11	286712	REVERSE FEED CONTROL LEVER HINGE STUD	X	X	X	X
12	314013-451	DISC SELECTOR MECHANISM MOUNTING PLATE SCREW LOCK WASHER	X	X	X	X
13	370451	REVERSE FEED CONTROL LEVER CONNECTION PLATE RETURN SPRING	X	X	X	X
14	313891-000	CAM CONTROLLED FEED CONNECTING ROD STABILIZING WASHER	X	X	X	X
15	313172-451	STITCH LENGTH CONTROL LEVER PIVOT LOCK WASHER	X	X	X	X
16	313177-451	STITCH LENGTH CONTROL LEVER NUT	X	X	X	X
7	286660-900	REVERSE FEED CONTROL LEVER	X	X	X	X

DEMAND RESPONSIVE NEEDLE TENSION SYSTEM
 MODEL: 9210 9217 9224 9240

REF. PART NO.	PART NO.	DESCRIPTION	9	9	9	9
			9	9	9	9
			2	2	2	2
			1	1	2	4
			0	7	4	0
1	286616-001	THREAD TENSION MODULE	X	X	X	X
2	313199	TENSION COVER MOUNTING RETAINER	X	X	X	X
3	313047-451	TENSION COVER RETAINING CLIP	X	X		
3	313047-452	TENSION COVER RETAINING CLIP			X	X
4	317478	GROUNDING SPRING (TENSION MODULE)			X	X

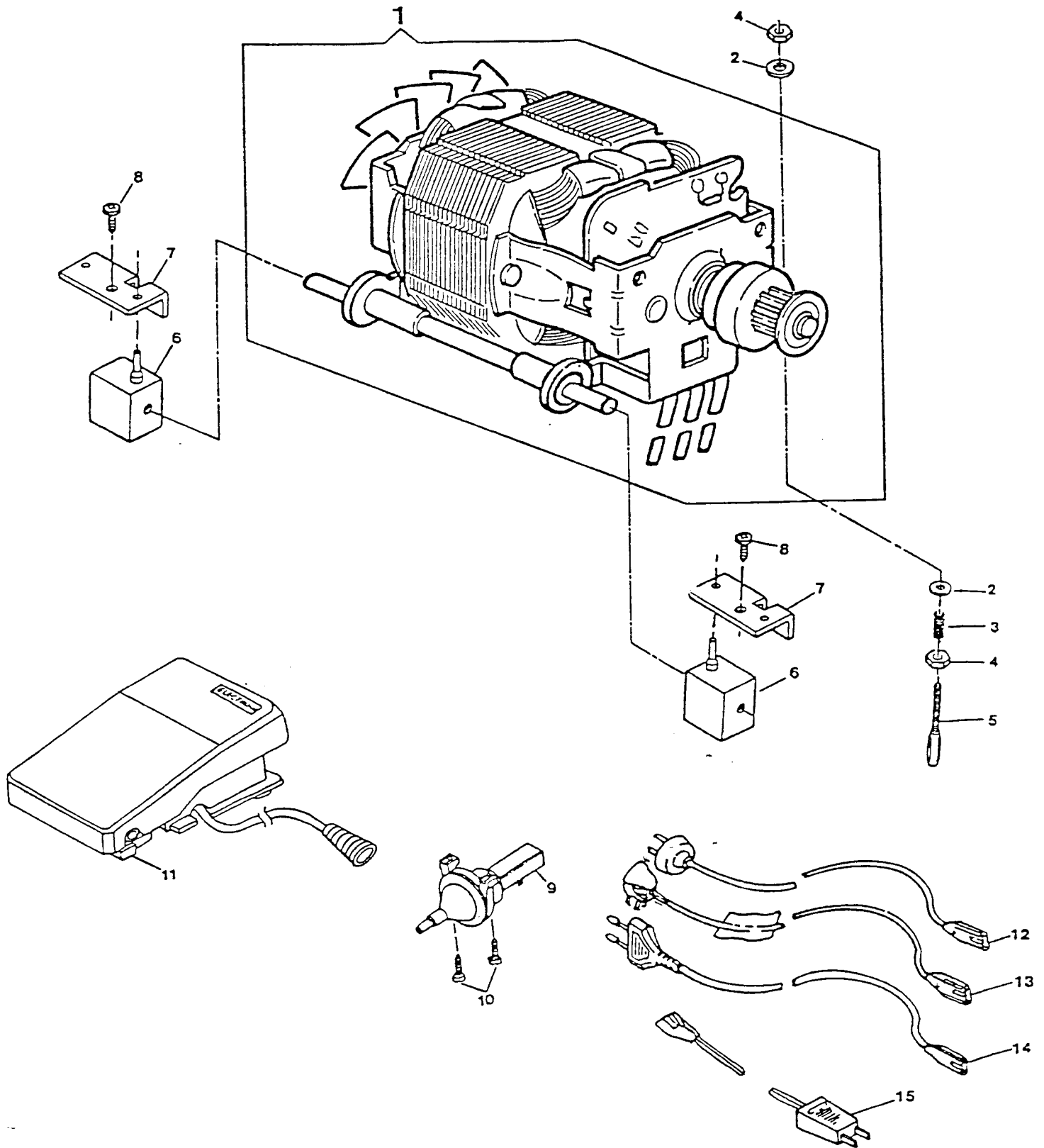



ELECTRICAL EQUIPMENT
 MODEL: 9210 9217 9224 9240

REF. PART NO.	PART NO.	DESCRIPTION	9	9	9	9
			2	2	2	2
			1	1	2	4
			0	7	4	0
1	988529-210	MOTOR COMPLETE (220/240VOLT)	X	X	X	X
1	988529-222	MOTOR COMPLETE (120VOLT)	X	X	X	X
2	37969	MOTOR ADJUSTING STUD NUT WASHER	X	X	X	X
3	314058	MOTOR BELT TENSION SPRING	X	X	X	X
4	53646	MOTOR ADJUSTING STUD NUT	X	X	X	X
5	988653-001	MOTOR ADJUSTING STUD	X	X	X	X
6	979329-001	RESILIENT MOUNT	X	X	X	X
7	988651-001	CLIP, RESILIENT MOUNT	X	X	X	X
8	113470-004	MOTOR MOUNTING SCREW	X	X	X	X
9	988549-005	PNEUMATIC TRANSDUCER	X	X	X	X
10	113444-003	PNEUMATIC TRANSDUCER MOUNTING SCREW	X	X	X	X
11	979583-003	PNEUMATIC CONTROLLER ASSEMBLY	X	X	X	X
11	319003-005	FOOT CONTROLLER (DUAL VOLTAGE) (FOR U.S.A. ONLY)	X	X	X	X
12	988638-004	APPLIANCE COUPLER (240VOLT) FOR AUSTRALIA	X	X	X	X
13	137902	APPLIANCE COUPLER (240VOLT) FOR U.K.	X	X	X	X
14	988638-001	APPLIANCE COUPLER (220VOLT) (FOR EUROPE)	X	X	X	X
15	988638-009	APPLIANCE COUPLER (120VOLT) FOR (U.S.A. & CANADA)	X	X	X	X

ACK

Power



ELECTRICAL EQUIPMENT
MODEL: 9210 9217 9224 9240

REF. PART NO.	PART NO.	DESCRIPTION	9	9	9	9
			2	2	2	2
			1	1	2	4
			0	7	4	0
1	317095-002	LINT AND HEAT SHIELD-ASSEMBLY	X	X	X	X
2	979585-006	ROCKER SWITCH	X	X	X	X
3	286751	APPLIANCE COUPLE HOLDER ASS'Y	X	X	X	X
4	113455-002	SCREW, CABLE TIE MOUNTING	X	X	X	X
5	604690-001	SELF LOCKING NYLON CABLE TIE	X	X	X	X
6	113455-003	SCREW, CABLE TIE MOUNTING AND TRANSFORMER MOUNTING	X	X	X	X
7	317347-201	TRANSFORMER ASSEMBLY WITH LEAD (LCD 120V)	X	X	X	X
7	317412-201	TRANSFORMER ASSEMBLY WITH LEAD (LCD 220V)	X	X	X	X
7	317413-201	TRANSFORMER ASSEMBLY WITH LEAD (240V)	X	X	X	X
9	979603-001	WEDGE BULB	X	X	X	X
10	988547-001	WASHER, P.C. BOARD MOUNTING SCREW	X	X	X	X
11	988547-002	WASHER, P.C. BOARD MOUNTING SCREW	X	X	X	X
12	113444-001	SCREW, P.C. BOARD MOUNTING	X	X	X	X
13	979584-201	SPEED CONTROL P.C. BOARD ASSEMBLY (120V)	X	X	X	X
13	979586-201	SPEED CONTROL P.C. BOARD ASSEMBLY (220/240V)	X	X	X	X
13	979612-201	SPEED CONTROL P.C. BOARD ASSEMBLY (220/240V) (SCAND)	X	X	X	X
14	317350-002	EXTENSION LEADS W/HOUSING PLUG (TRANSFORMER)	X	X	X	X

#15- *Light socket Asy.*
317187 002 *92" pencils*

reflector - 317181002

29608
2108

ELECTRICAL EQUIPMENT

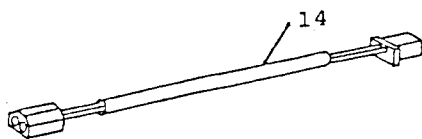
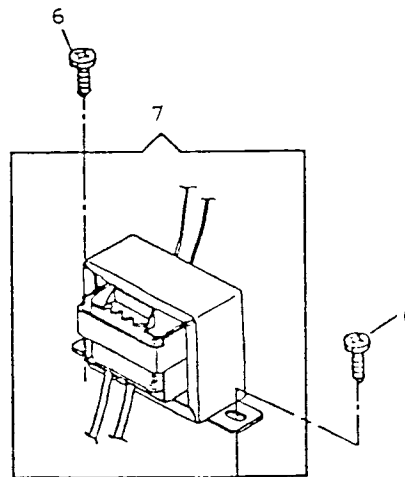
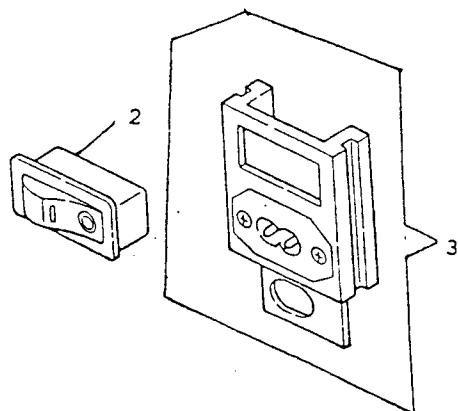
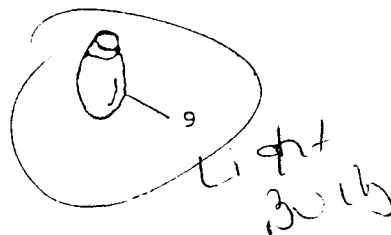
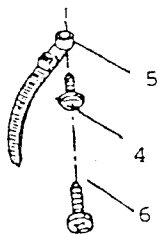
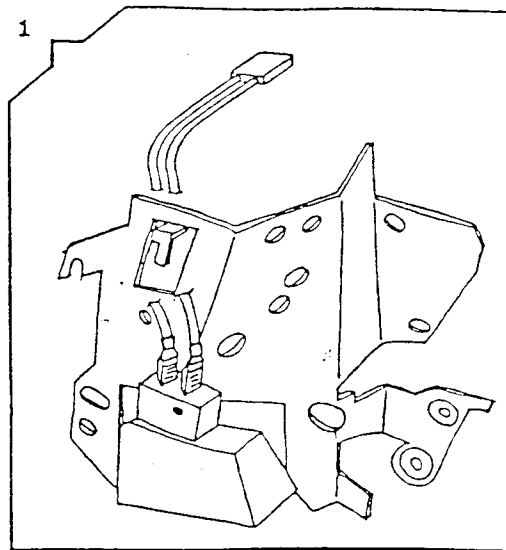
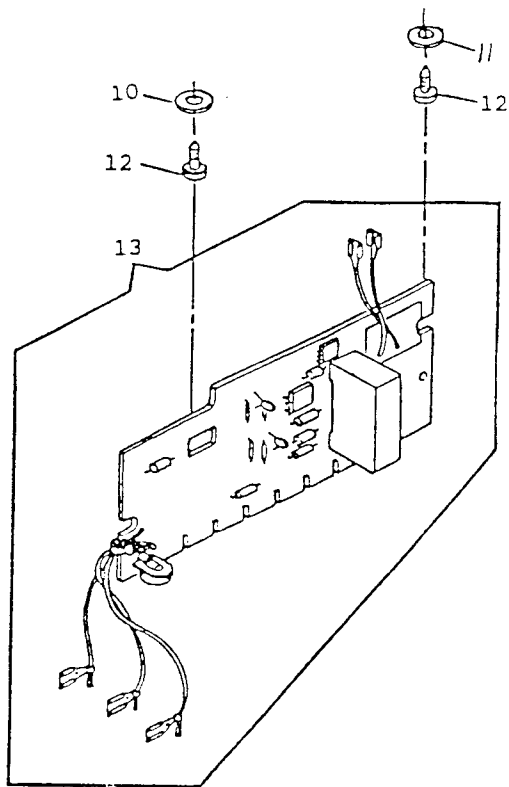

ELECTRICAL EQUIPMENT (CONT.)

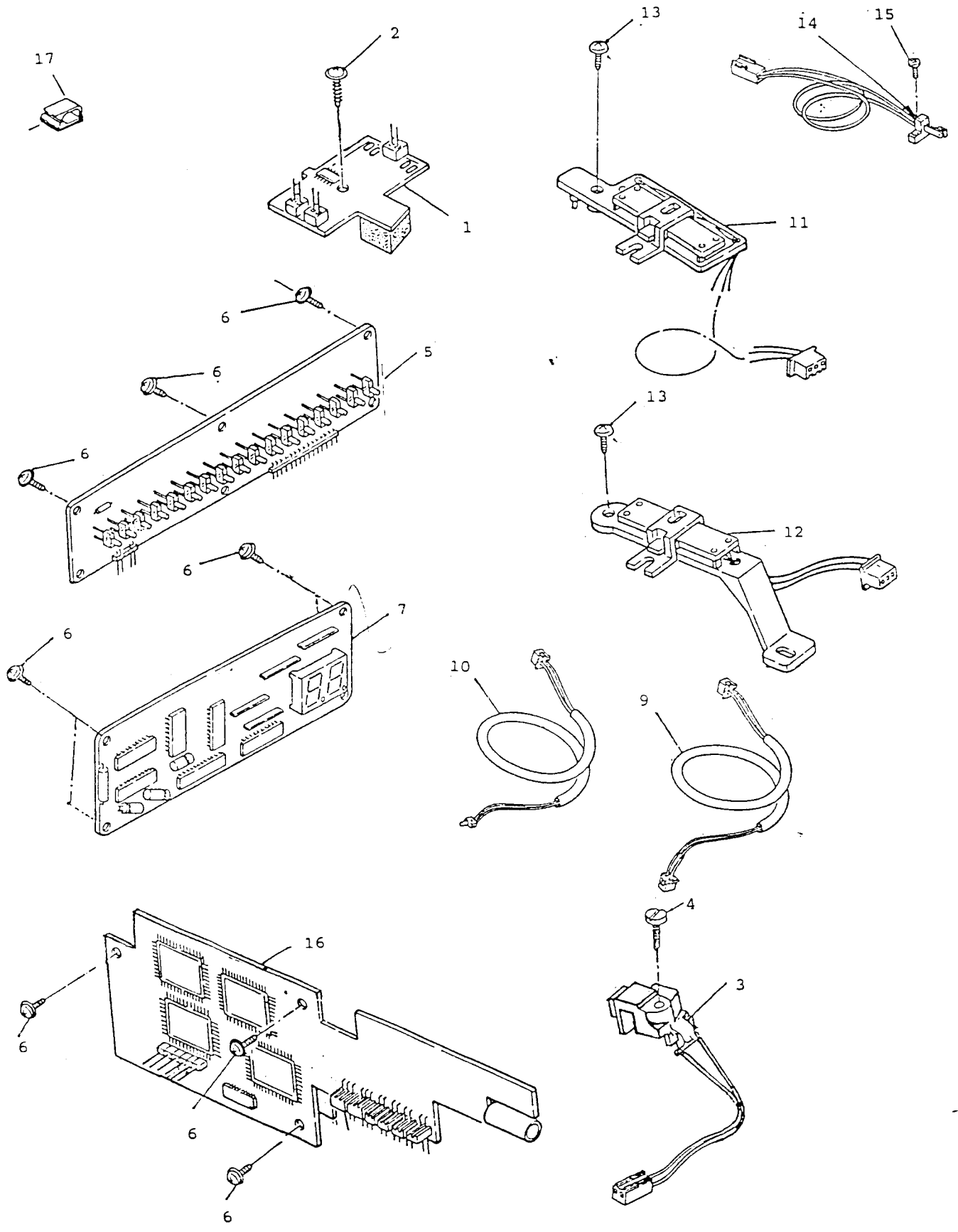

ELECTRICAL EQUIPMENT (CONT.)
 MODEL: 9210 9217 9224 9240

REF. PART NO.	PART NO.	DESCRIPTION	9	9	9	9
			9	9	9	9
			2	2	2	2
			1	1	2	4
			0	7	4	0
1	286785	LOW BOBBIN P.C. BOARD ASSEMBLY				
2	113455-017	SCREW, LOW BOBBIN P.C. BOARD MOUNTING				X
3	286787	INFRARED LED ASSEMBLY				X
4	113361-003	SCREW, INFRARED LED ASSEMBLY MOUNTING				X
5	286705	LED P.C. BOARD COMPLETE				X
5	286707	LED P.C. BOARD COMPLETE				X
6	317480-002	SCREW, LED/LCD P.C. BOARD MOUNTING	X			
7	286754	LED MODULE (SEVEN SEGMENT)	X	X	X	X
9	286814	LEAD, (POWER).				X
10	286815	LEAD, (LED)				X
11	286808	STITCH LENGTH SENSOR BRACKET W/LEAD ASSEMBLY				X
12	286810	STITCH WIDTH SENSOR BRACKET W/LEAD ASSEMBLY				X
13	113455-001	SCREW, SENSOR BRACKET MOUNTING				X
14	286822	MICRO SWITCH ASSEMBLY				X
15	286832-451	SCREW, MICRO SWITCH MOUNTING				X
16	286755-000	SMART LCD MODULE				X
17	317340	SELF-ADHSIVE WIRE CLIP				X

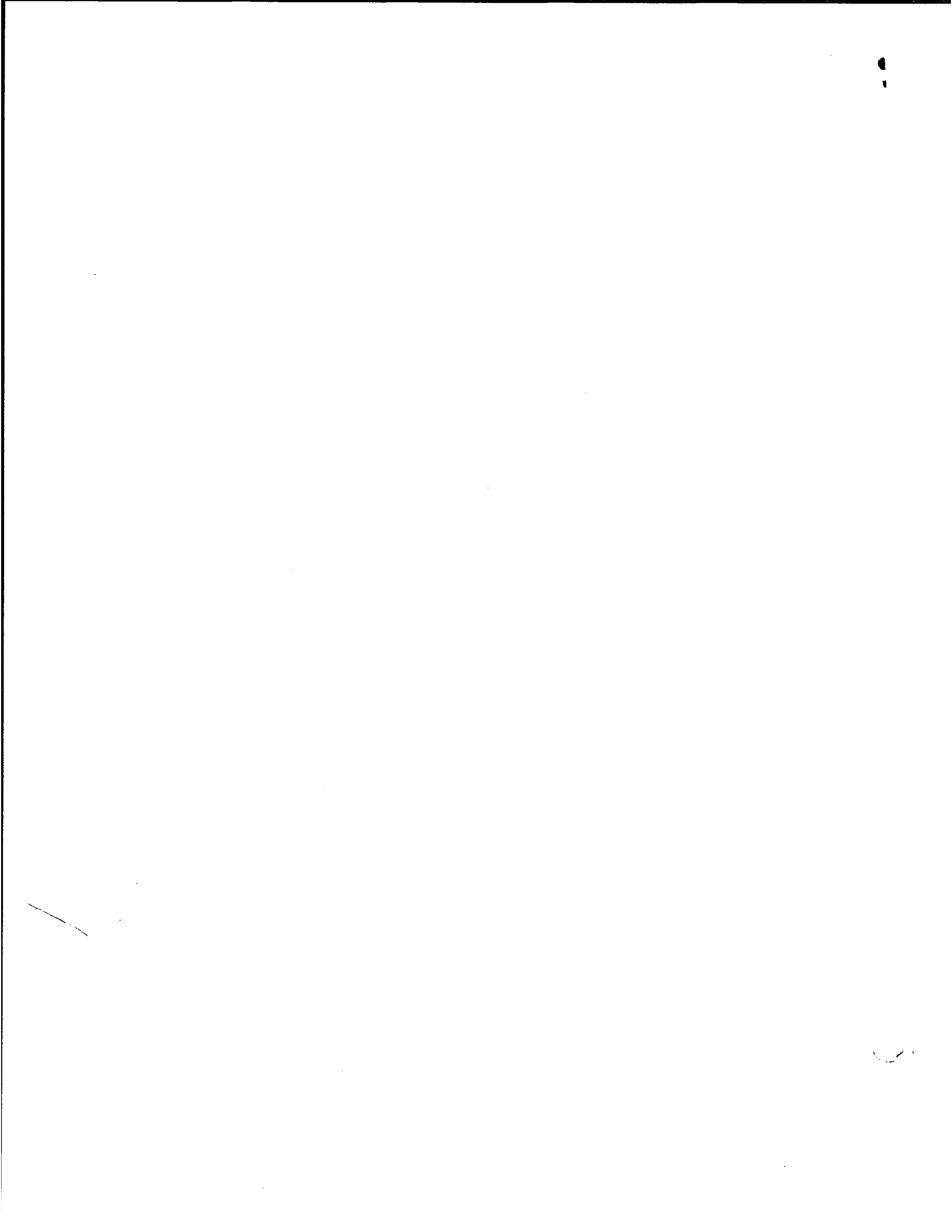

DUAL-VOLTAGE

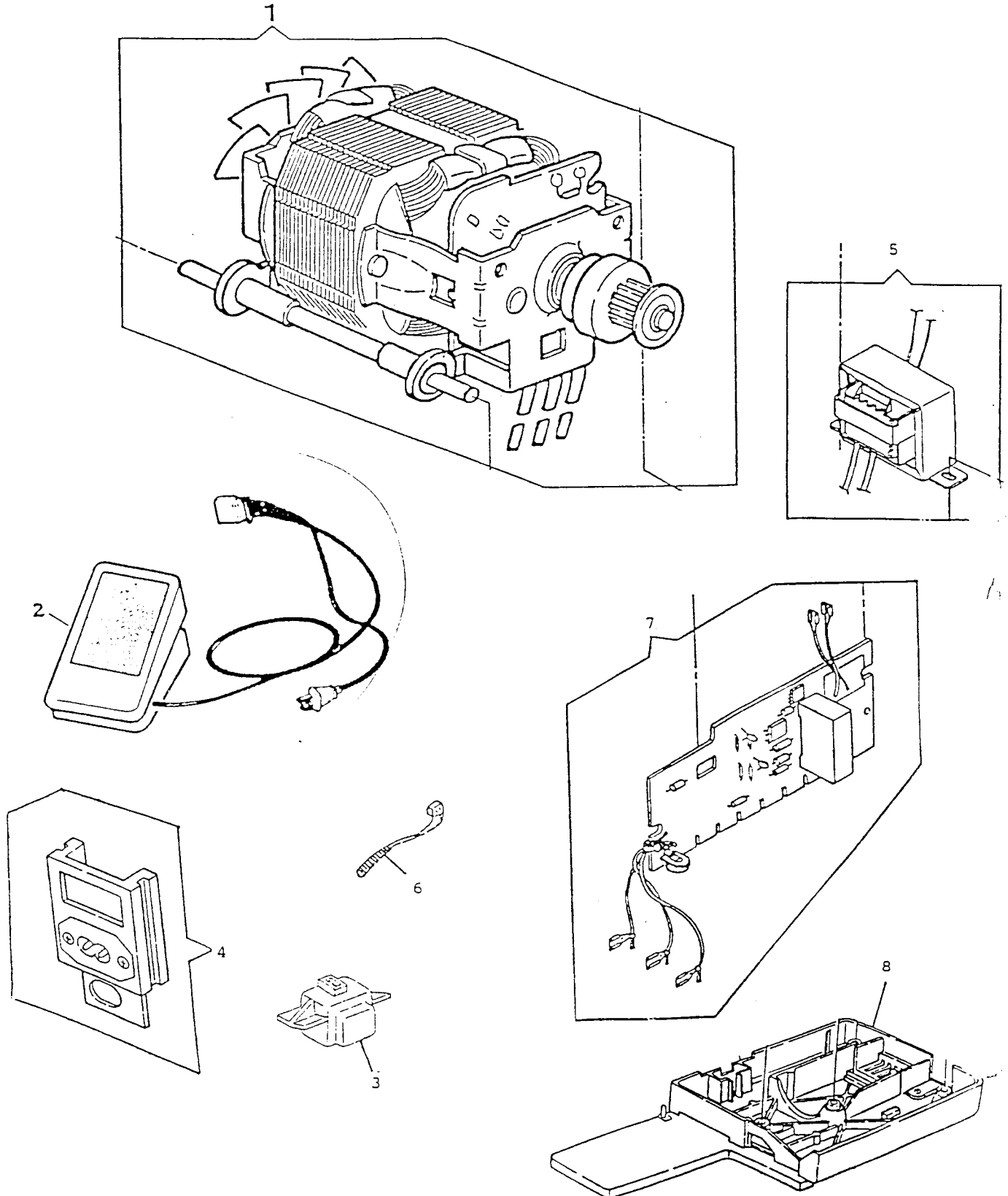

ELECTRICAL EQUIPMENT (DUAL VOLTAGE)
 MODEL: 9210 9217

REF. PART NO.	PART NO.	DESCRIPTION	9N	9N	9N	9N	9N	9N
			25	25	25	25	25	25
			10	10	10	10	10	10
			00	01	02	70	71	72
1	317375	MOTOR WITH RECEPTACLE	X	X	X	X	X	X
2	<u>317281-001</u>	<u>FOOT CONTROLLER WITH PACKING</u>	X	X	X	X	X	X
3	286856-901	CARRIER WITH GRAPHICS (VOLTAGE SELECTOR SWITCH)	X	X	X	X	X	X
4	286854	APPLIANCE COUPLE HOLDER ASS'Y	X	X	X	X	X	X
5	286829	TRANSFORMER COMPLETE	X	X	X	X	X	X
6	540899	TY-WRAP SELF LOCKING (ALT:605600-001)(DUAL VOLTAGE)	X	X	X	X	X	X
7	286827-001	SPEED CONTROL P.C. BOARD ASSEMBLY	X	X	X	X	X	X
8	286539-002	BASE PLATE ASSEMBLY	X	X	X	X	X	X

*DUAL
 VOLTAGE*