

**SINGER**

**9022/9420/9423/9432/9408N304**

# LIST OF PARTS

## *Sewing Machine Models*

9022

9420

9423

9432

9408N304

by **SINGER**\*



A Publication of Product Support  
International Group Engineering

Part No.317161-021

Printed in Taiwan

\* A trademark of The Singer Company.  
Copyright 1994, Singer Sewing Machine Company

All rights reserved throughout the world

## INDEX

PAGE NO.	SUBASSEMBLY
1, 2	ATTACHMENT SET
3, 4	COVERS AND ADD ONS
5, 8	ARM TOP COVER
9, 10	ARM SHAFT DRIVE SYSTEM
11, 12	HAND WHEEL
13, 14	COAXIAL PRESSER BAR SYSTEM
15, 16	NEEDLE BAR & THREAD TAKE-UP
17, 18	ALPHA FEED
19, 20	HOOK SYSTEM (APOLLO)
21, 22	HOOK AND BOBBIN WINDING SYSTEM (CENTAUR)
23, 28	PATTERN, STITCH LENGTH CONTROL & CAM CONTROLLED FEED
29, 30	DEMAND RESPONSIVE NEEDLE TENSION SYTEM
31, 34	ELECTRICAL EQUIPMENT

ATTACHMENT SET  
 MODEL: 9022 9420 9423 9432 9408N304

REF. PART NO.	PART NO.	DESCRIPTION	9	9	9	9	9	9
			0	4	4	4	4	43
			2	2	2	3	00	
			2	0	3	2	S4	
1	313030-007	ATTACHMENT COMPLETE	X	X	X	X	X	X
2A	317396	ACCESSARY BAG	X	X	X	X	X	X
5	172336-001	BOBBIN (APOLLO)	X	X	X	X	X	X
7	353364	NEEDLE PACK (ALT: 384064)	X	X	X	X	X	X
9	546358	LINT BRUSH	X	X	X	X	X	X
13	313992-451	PRESSER FOOT PLAT (4-STEPS) FOR SEWING BUTTONHOLE	X	X	X	X	X	X
15	171480	PRESSER FOOT PLATE (SNAP-ON) FOR CORDING AND SLIDE FASTENERS COMPLETE	X	X	X	X	X	X
17	171463	SPECIAL PURPOSE PRESSER FOOT PLATE (SNAP-ON)	X	X	X	X	X	X
20	421588	FINGER GUARD (FOR GERMANY & ITALY)	X	X	X	X	X	X
21	171110	BLINDSTITCH GUIDE	X	X	X	X	X	X

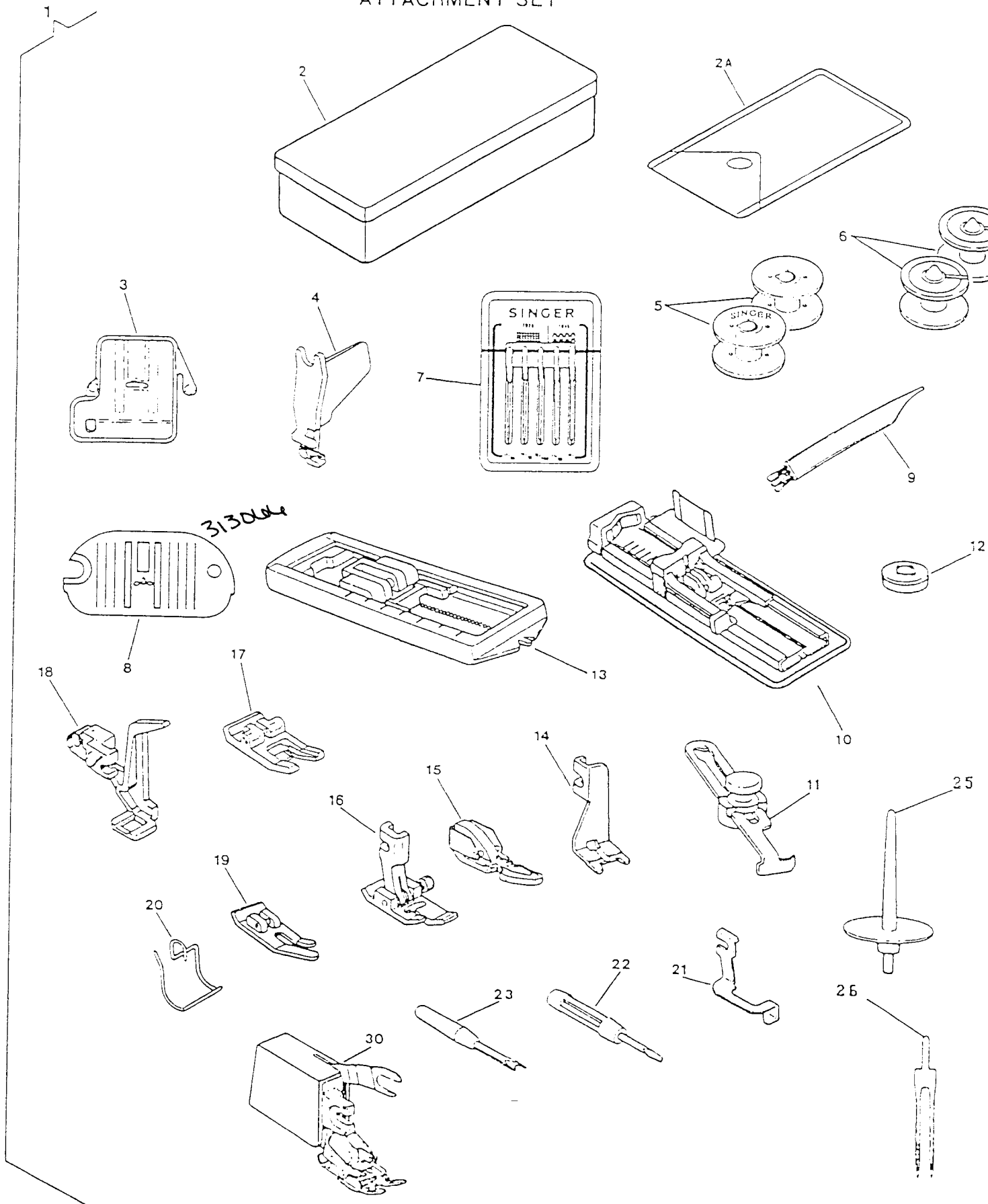

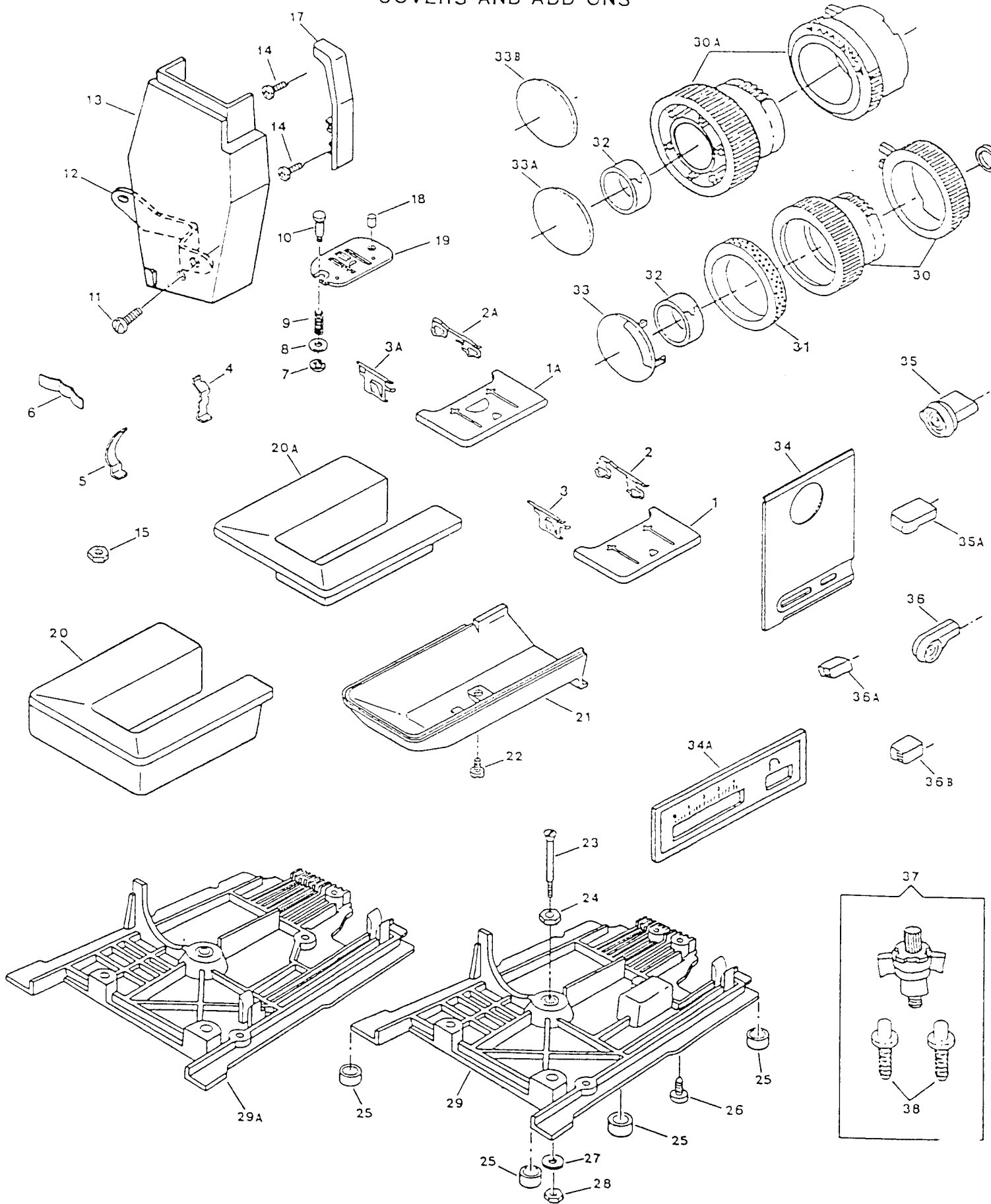

COVERS AND ADD OMS  
 MODEL: 9022 9420 9423 9432 9408N304

REF. NO.	PART NO.	DESCRIPTION	9	9	9	9	9N
			0	4	4	4	43
			2	2	2	3	00
			2	0	3	2	84
1	314666	BED SLIDE ASSEMBLY COMPLETE (APOLLO)	X	X	X	X	X
2	314669	BED SLIDE SPRING (RIGHT)	X	X	X	X	X
3	314670	BED SLIDE SPRING (LEFT)	X	X	X	X	X
4	313178	BED SLIDE STOP	X	X	X	X	X
5	313179	BED SLIDE STOP SPRING	X	X	X	X	X
6	313118	CLOTH PLATE SPRING	X	X	X	X	X
7	313098	THROAT PLATE POUNGER RETAINING RING	X	X	X	X	X
8	549426-451	THROAT PLATE PUNGER WASHER	X	X	X	X	X
9	312805	THROAT PLATE PLUNGER SPRING	X	X	X	X	X
10	312804	THROAT PLATE PLUNGER	X	X	X	X	X
11	113521-451	FACE PLATE MOUNTING SCREW	X	X	X	X	X
12	314263	FACE PLATE MOUNTING BRACKET	X	X	X	X	X
13	314259-004	FACE PLATE COMPLETE	X	X	X	X	
13	314259-006	FACE PLATE COMPLETE					X
14	113470-003	THREAD TAKE-UP COVER MOUNTING SCREW	X	X	X	X	X
15	313049	BED INSERT NUT	X	X	X	X	X
17	314718-455	THREAD TAKE-UP COVER	X	X	X	X	
17	314718-458	THREAD TAKE-UP COVER					X
18	353624	THROAT PLATE LOCATING PIN	X	X	X	X	X
19	312777	THROAT PLATE FOR ZIG-ZAG SEWING	X	X	X	X	
20A	317379-900	CLOTH PLATE	X	X	X	X	
21	312773-452	BED COVER (TUBULAR)	X	X	X	X	X
22	354633-452	BED COVER (TUBULAR) SCREW	X	X	X	X	X
23	313052-451	BOTTOM COVER MOUNTING BOLT	X	X	X	X	X
24	313173-451	BOTTOM COVER MOUNTING BOLT RETAINING NUT	X	X	X	X	X
25	313909-451	BED LEG CUSHION	X	X	X	X	X
26	113455-002	BED COVER PLATE (BOTTOM) SCREW	X	X	X	X	X
27	314712-451	BOTTOM COVER MOUNTING BOLT WASHER	X	X	X	X	X
28	313177-452	BOTTOM COVER MOUNTING BOLT MOUNTING NUT	X	X	X	X	X
29A	314774-001	BED COVER PLATE (BOTTOM)	X	X	X	X	
29A	314774-003	BED COVER (DUAL VOLTAGE FOR U.S.A./KOREA/GERMANY & H.K.)					X
30A	314239-461	PATTERN SELECTOR KNOB AND STITCH BALANCE KNOB KIT ASSEMBLY (FOR U.S.A.)	X	X	X	X	
30A	314239-467	PATTERN SELECTOR KNOB AND STITCH BALANCE KNOB KIT ASSEMBLY (FOR EUROPE)	X	X	X	X	
30A	314239-471	PATTERN SELECTOR KNOB AND STITCH BALANCE KNOB KIT ASSEMBLY					X
32	313535	PATTERN SELECTOR KNOB COMPRESSION RING	X	X	X	X	X
33A	314744-481	PATTERN SELECTOR KNOB TRIM PLATE					X
33A	314744-492	PATTERN SELECTOR KNOB TRIM PLATE (FOR EUROPE)				X	
33A	314744-493	PATTERN SELECTOR KNOB TRIM PLATE	X				
33A	314744-488	PATTERN SELECTOR KNOB TRIM PLATE					X
33A	314744-489	PATTERN SELECTOR KNOB TRIM PLATE (FOR U.S.A.)				X	
33A	314744-490	PATTERN SELECTOR KNOB TRIM PLATE		X			
34A	317009-006	STITCH LENGTH CONTROL PANEL WITH GRAPHICS	X		X		
34A	317009-015	STITCH LENGTH CONTROL PANEL WITH GRAPHICS		X			
34A	317009-016	STITCH LENGTH CONTROL PANEL WITH GRAPHICS (FOR U.S.A.)				X	X
34A	317009-022	STITCH LENGTH CONTROL PANEL WITH GRAPHICS					X
35A	312657-460	REVERSE FEED CONTROL LEVER KNOB (FOR U.S.A.)		X	X	X	
35A	312657-464	REVERSE FEED CONTROL LEVER KNOB (PLASTIC)	X		X		
35A	312657-467	REVERSE FEED CONTROL LEVER KNOB					X
36A	314676-460	BIGHT AMPLITUDE CONTROL LEVER KNOB (FOR U.S.A.)		X	X	X	
36A	314676-464	BIGHT AMPLITUDE CONTROL LEVER KNOB (PLASTIC)	X		X		
36A	314676-467	BIGHT AMPLITUDE CONTROL LEVER KNOB					X
36B	312664-468	STITCH LENGTH CONTROL LEVER KNOB					X
36B	312664-460	STITCH LENGTH CONTROL LEVER KNOB (FOR U.S.A.)		X	X	X	
36B	314664-465	STITCH LENGTH CONTROL LEVER KNOB (PLASTIC)	X		X		
37	313180	MACHINE HOLD DOWN MOUNTING KIT	X	X	X	X	X
38	148869	MACHINE LOCATOR PIN	X	X	X	X	X



ARM TOP COVER  
 MODEL: 9022 9420 9423 9432 9408N304

REF. PART NO.	NO.	DESCRIPTION	9	9	9	9	SN
			0	4	4	4	43
			2	2	2	3	00
			2	0	3	2	84
1A	317027-015	ARM TOP COVER ASSEMBLY WITH HANDLE					
1A	317027-015	ARM TOP COVER COMPLETE WITH HANDLE (9022N403)	X				X
1A	317122-064	ARM TOP COVER COMPLETE WITH HANDLE (FOR U.S.A.)		X			
1A	317122-065	ARM TOP COVER COMPLETE WITH HANDLE (FOR U.S.A.)				X	
1A	317122-074	ARM TOP COVER ASSEMBLY WITH HANDLE (TEMPO 80)				X	
1A	317122-081	ARM TOP COVER ASSEMBLY WITH HANDLE				X	
2A	314640-801	CONTROL PANEL WITH GRAPHICS (FOR U.S.A.)					X
2A	314640-803	CONTROL PANEL WITH GRAPHICS (TEMPO 80)				X	
2A	314640-929	CONTROL PANEL WITH GRAPHICS				X	
2A	314640-956	CONTROL PANEL WITH GRAPHICS		X			
2A	317197-903	CONTROL PANEL WITH GRAPHICS					X
2A	317197-904	CONTROL PANEL WITH GRAPHICS					X
3A	314703-806	CONTROL PANEL EXTENSION WITH GRAPHICS (FOR U.S.A.)	X				
3A	314703-811	CONTROL PANEL EXTENSION WITH GRAPHICS (TEMPO 80)				X	X
3A	314703-929	CONTROL PANEL EXTENSION WITH GRAPHICS				X	
3A	314703-955	CONTROL PANEL EXTENSION WITH GRAPHICS (9022N403)				X	
3A	314703-958	CONTROL PANEL EXTENSION WITH GRAPHICS	X				
4	312901	BOBBIN WINDER ASSEMBLY					X
5	312897	BOBBIN WINDER LEVER SPRING	X	X	X	X	X
6	312613	BOBBIN WINDER LEVER HING SCREW SHOULDER WASHER	X	X	X	X	X
7	354927-004	BOBBIN WINDER LEVER HING SCREW	X	X	X	X	X
8	354927-001	ARM TOP COVER MOUNTING SCREW	X	X	X	X	X
10	179967-456	SPOOL PIN THREAD LEAD-OFF	X	X	X	X	X

ARM TOP COVER

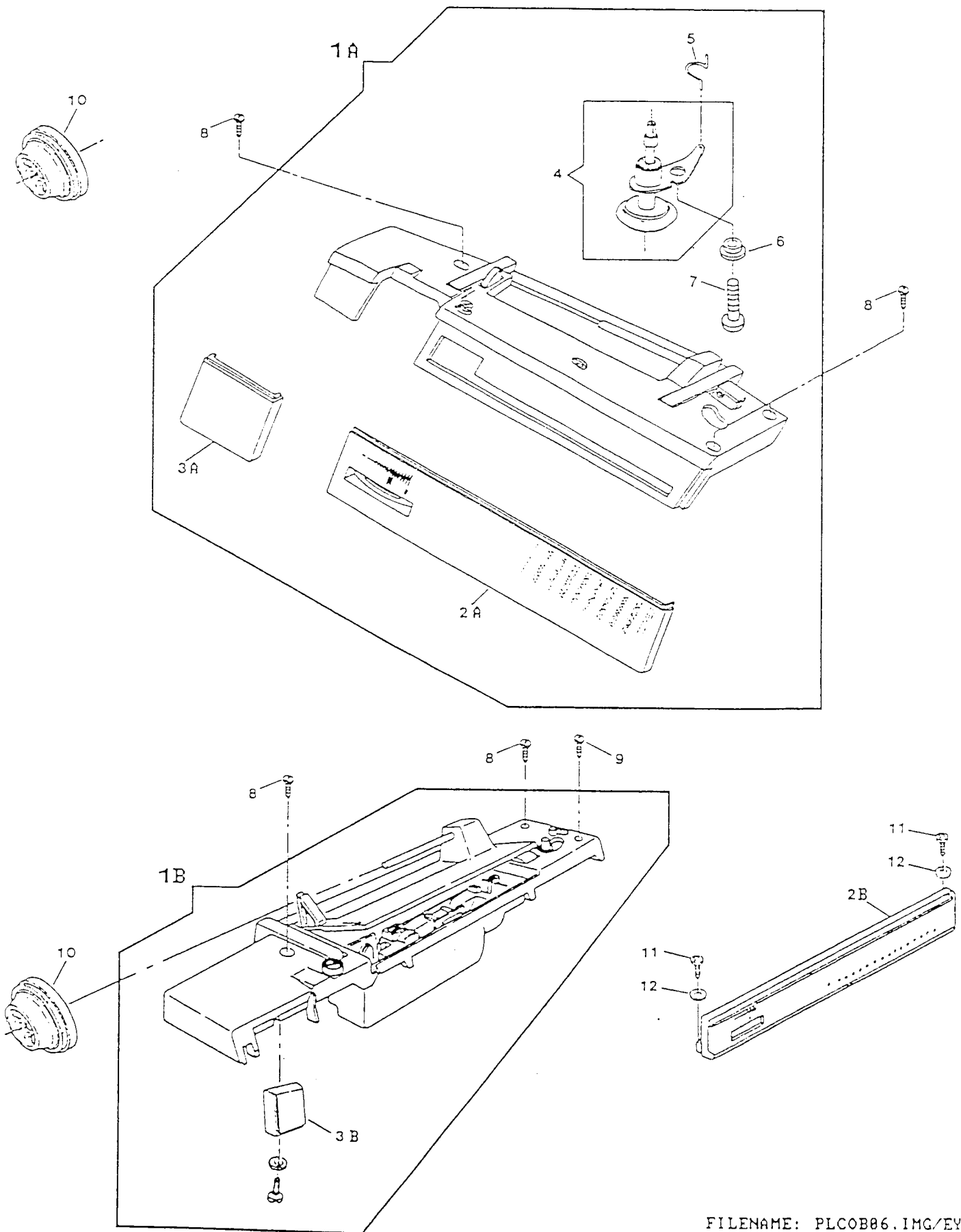

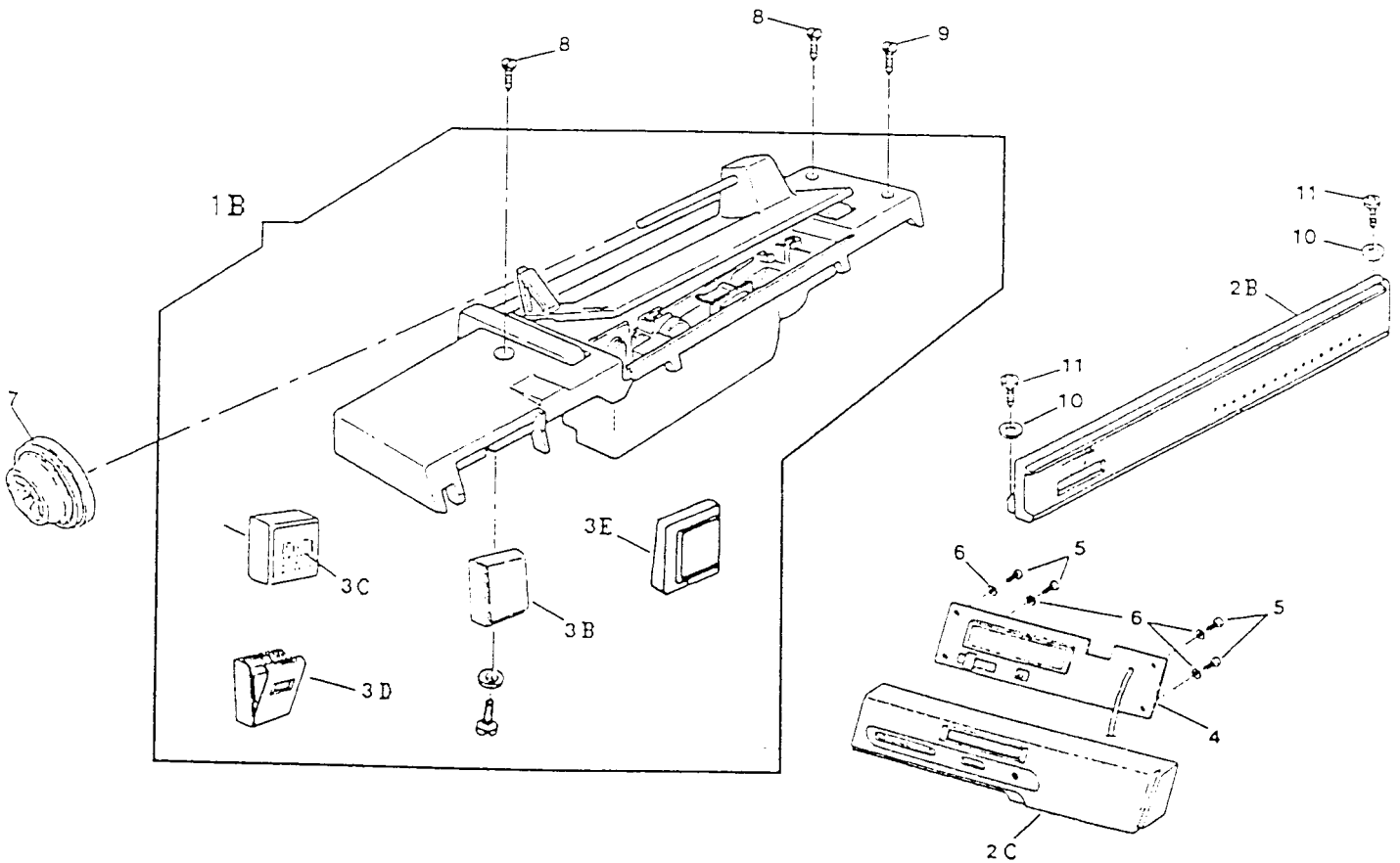
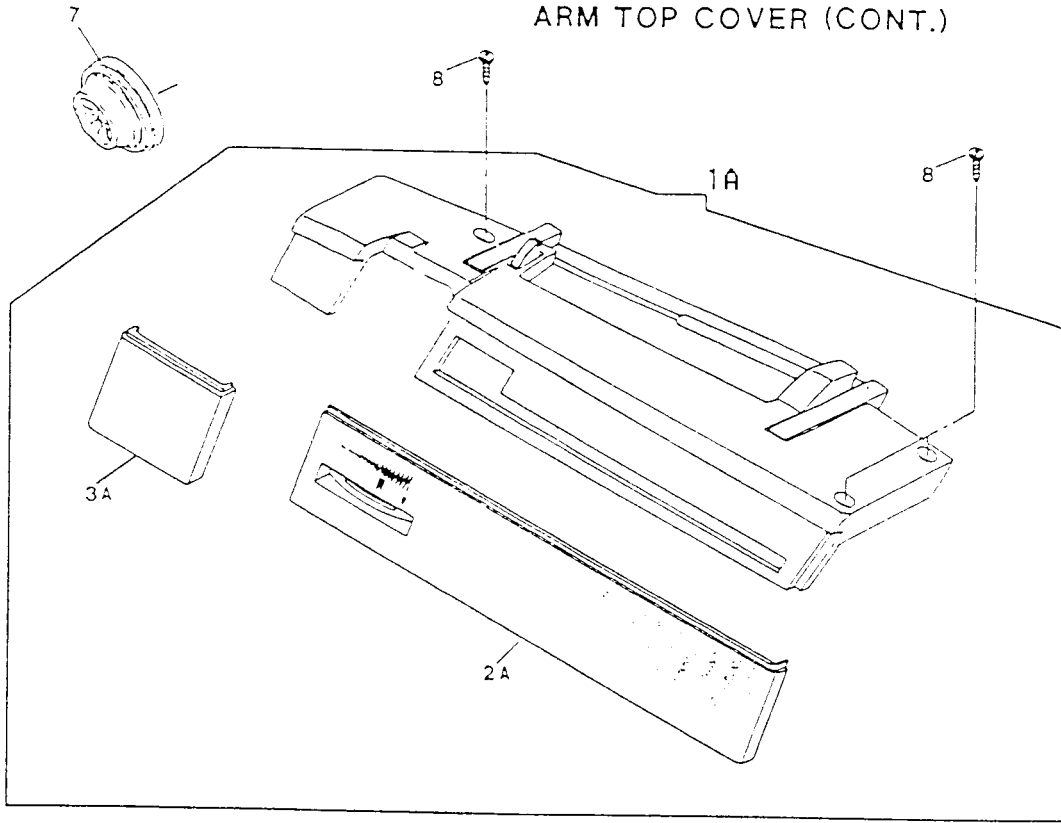

REV. DATE: 03/01/94

PAGE: 08

BLANK PAGE

ARM SHAFT DRIVE SYSTEM  
 MODEL: 9022 9420 9423 9432 9402N304

REF. NO.	PART NO.	DESCRIPTION	9	9	9	9	9N
			0	4	4	4	43
			2	2	2	3	00
			2	0	3	2	84
1	113455-001	ARM SHAFT (HORIZONTAL) BUSHING (LEFT & RIGHT) CLAMP SCREW	X	X	X	X	X
2	312796	ARM SHAFT (HORIZONTAL) BUSHING (LEFT & RIGHT) CLAMP	X	X	X	X	X
3	313111-002	ARM SHAFT ASSEMBLY (APOLLO)	X	X	X	X	X
4	603975-011	BELT (ROTATING HOOK DRIVE) ALT: 603975-012	X	X	X	X	X
5	313195	IDLER BRACKET ASSEMBLY	X	X	X	X	X
6	314041-451	ROTATING HOOK DRIVING BELT TENSION ADJUSTER SCREW WASHER	X	X	X	X	X
7	113455-002	ROTATING HOOK DRIVING BELT TENSION ADJUSTER SCREW	X	X	X	X	X
8	313153	HAND WHEEL RETAINING RING	X	X	X	X	X
9	314010	ROTATING HOOK DRIVE SHAFT SUB-ASSEMBLY	X	X	X	X	X
10	313816	ROTATING HOOK DRIVE SHAFT BUSHING (SELF-ALIGNING) CLAMP	X	X	X	X	X
11	314013-451	ROTATING HOOK DRIVE SHAFT BUSHING (SELF-ALIGNING) CLAMP SCREW AND ARM SHAFT BUSHING CLAMP SCREW LOCK WASHER	X	X	X	X	X

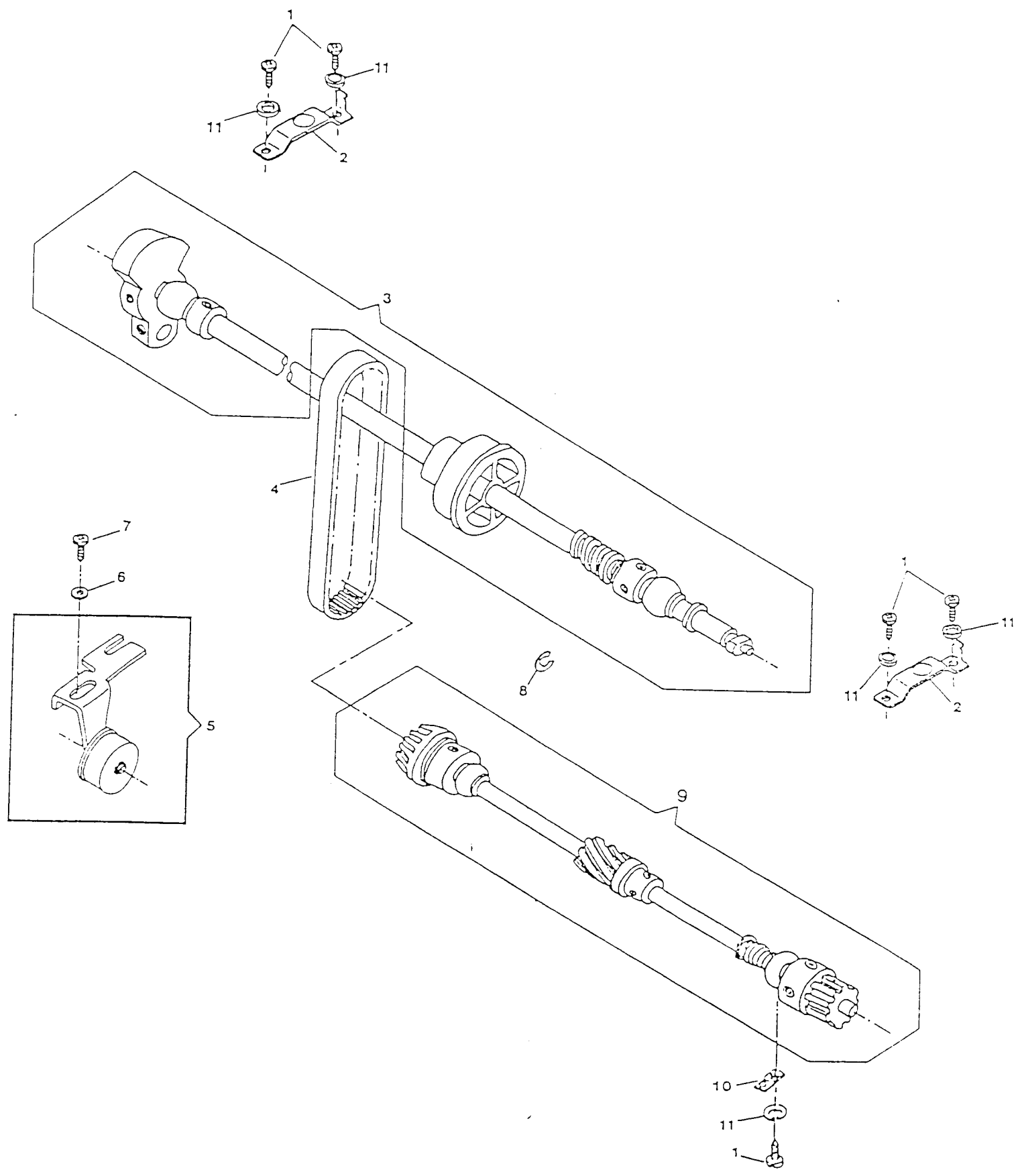

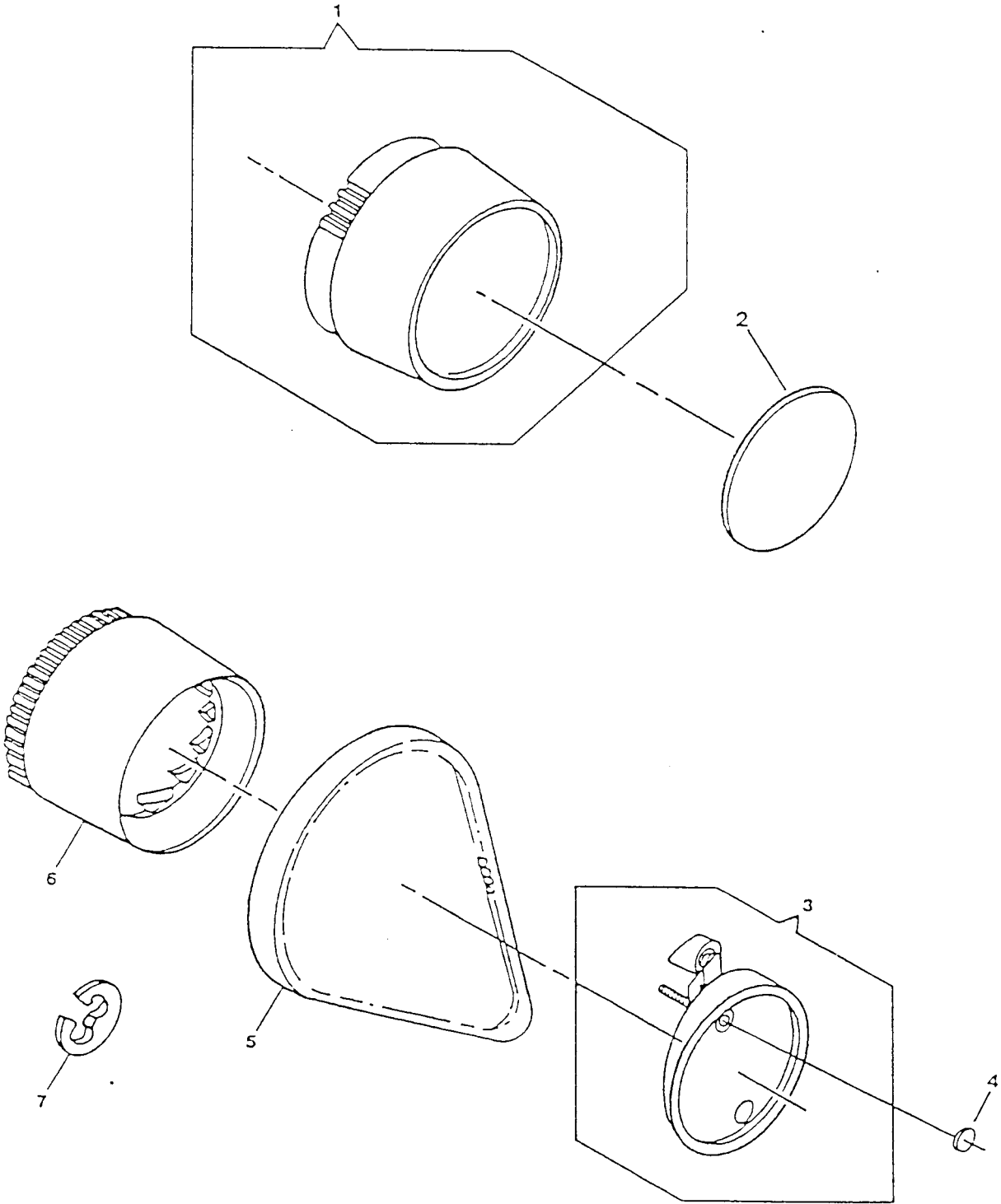

HAND WHEEL  
 MODEL: 9022 9420 9423 9432 9403N304

REF. PART NO.	DESCRIPTION	9	9	9	9	9N
		0	4	4	4	43
		2	2	2	3	00
		2	0	3	2	84
3	313185-451 HAND WHEEL CLUTCH PLATE ASSEMBLY	X	X	X	X	X
4	314733-920 HAND WHEEL ACCESS PLATE (APOLLO)	X	X	X	X	X
5	31262S-001 BELT (MOTOR DRIVE) ALT: 979285-001	X	X	X	X	X
6	312625-453 HAND WHEEL	X	X	X	X	X
7	313153 HAND WHEEL RETAINING RING	X	X	X	X	X



COAXIAL PRESSER BAR SYSTEM FOR NEW HEAD END  
 MODEL: 9022 9420 9423 9432 9408N304

REF. NO.	PART NO.	DESCRIPTION	9	9	9	9	9N
			0	4	4	4	43
			2	2	2	3	00
			2	0	3	2	84
1	314695-001	HEAD END MODULE (APOLLO)	X	X	X	X	X
2	314591	FACE PLATE MOUNTING BRACKET	X	X	X	X	X
3	313955-451	HEAD END MOUNTING PLATE LOCK WASHER	X	X	X	X	X
4	113455-012	HEAD END MOUNTING PLATE SCREW	X	X	X	X	X
5	163706-451	PRESSER FOOT SHANK (SNAP-ON)	X	X	X	X	X
6	313150	PRESSER FOOT PLATE (SNAP-ON) FOR ZIG-ZAG SEWING	X	X	X	X	X
7	113531-451	PRESSER FOOT THUMB SCREW	X	X	X	X	X
9	113455-001	NEEDLE THREAD TENSION RELEASE LEVER HINGE SCREW	X	X	X	X	X
10	314041-451	NEEDLE THREAD TENSION RELEASE LEVER RETAINING WASHER	X	X	X	X	X
11	317401	NEEDLE THREAD TENSION RELEASE LEVER ASSEMBLY	X	X	X	X	X
12	N2045-014	NEEDLE (SIZE NO. 14)	X	X	X	X	X
13	113408-001	NEEDLE BAR DRIVING ARM BALL JOINT SCREW	X	X	X	X	X
14	931929-004	NEEDLE BAR DRIVING ARM BALL JOINT SCREW WASHER	X	X	X	X	X
15	314690	THREAD PINCH PLATE	X	X	X	X	X
16	314582	PRESSER BAR LIFTER	X	X	X	X	X

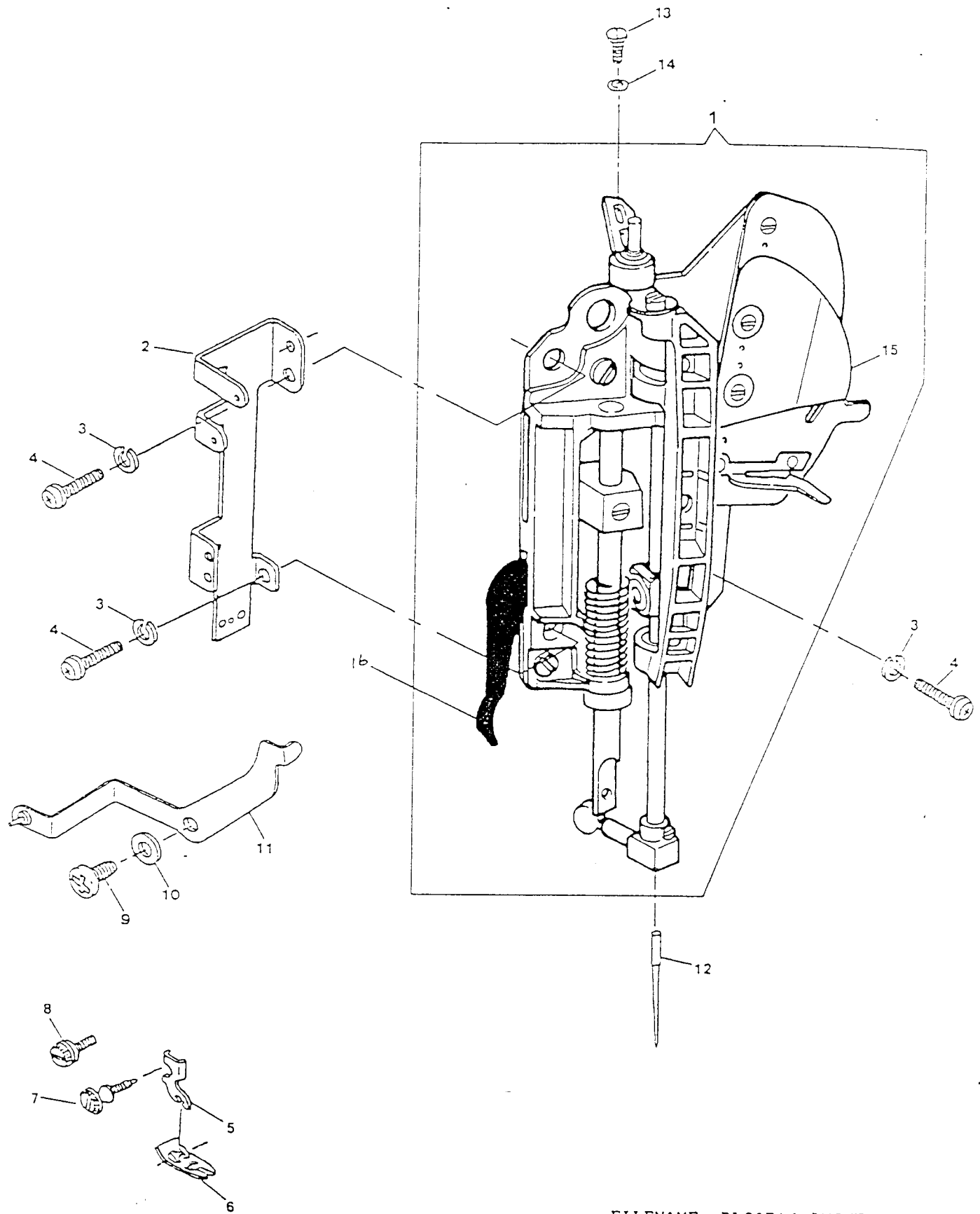

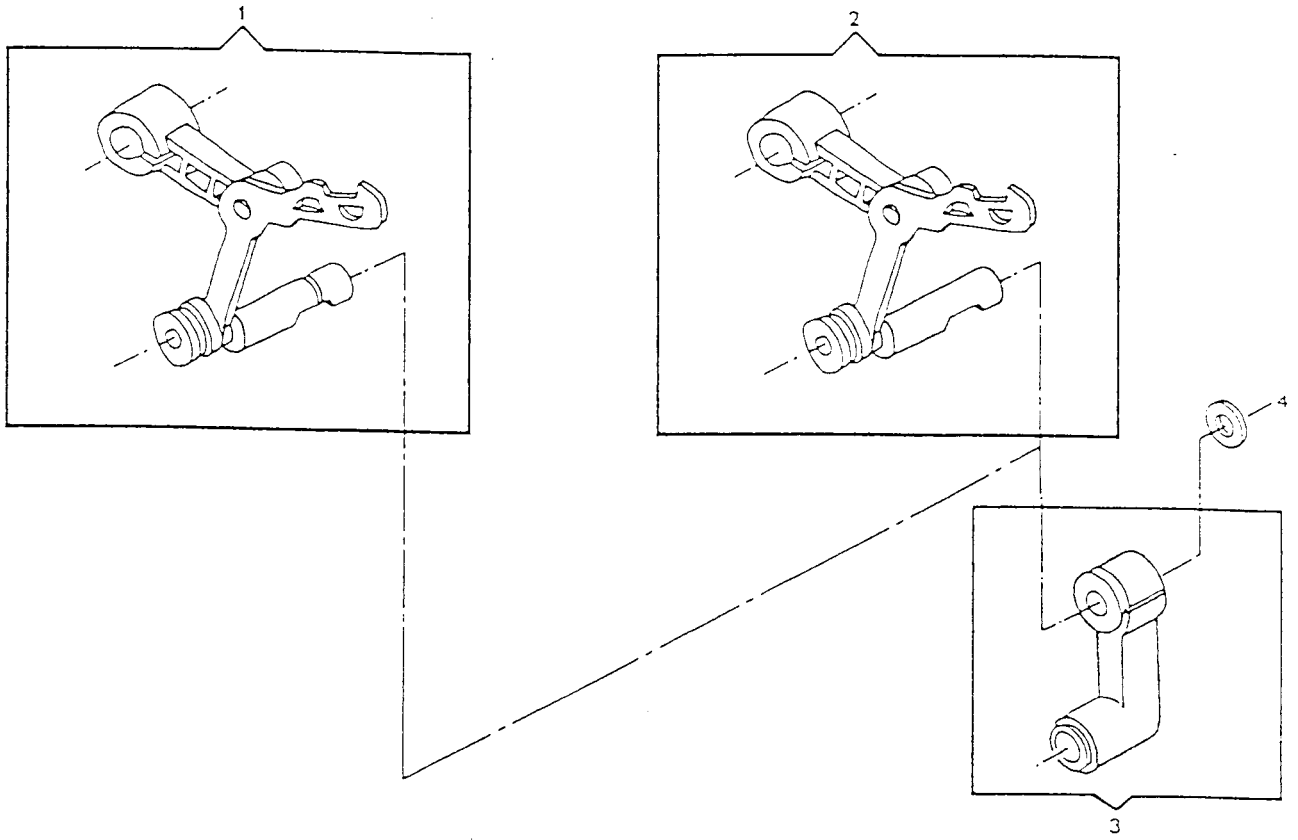

NEEDLE BAR & THREAD TAKE-UP FOR NEW HEAD END  
 MODEL: 9022 9420 9423 9432 9408N304

REF. PART NO.	PART NO.	DESCRIPTION	9	9	9	9	9N
			0	4	4	4	43
			2	2	2	3	00
			2	0	3	2	34
1	314694	THREAD TAKE-UP COMPLETE (APOLLO)	X	X	X	X	X
3	137528-901	NEEDLE BAR CONNECTING LINK	X	X	X	X	X
4	314071	WASHER, THREAD TAKE-UP LEVER	X	X	X	X	X

ALPHA FEED  
 MODEL: 9022 9420 9423 9432 9408N304

REF. PART NO.	PART NO.	DESCRIPTION	9	9	9	9	9N
			0	4	4	4	43
			2	2	2	3	00
			2	0	3	2	84
1	141920-452	FEED DOG SCREW	X	X	X	X	X
2A	312679	FEED DOG (APOLLO) ALT:313171	X	X	X	X	X
3	314140-002	ALPHA FEED MODULE (ALT:313011)	X	X	X	X	X
4	312851	FEED BAR PIVOT HING STUD CLAMP	X	X	X	X	X
5	113455-003	CLAMP SCREW	X	X	X	X	X
6	314141	FEED BAR ASSEMBLY	X	X	X	X	X
7	354921-451	FEED & ROTATING HOOK DRIVE SHAFT BEARING BLOCK SCREW	X	X	X	X	X
8	314070	ROTATING HOOK DRIVE SHAFT BUSHING SPING	X	X	X	X	X
9	514674-451	FEED & ROTATING HOOK DRIVE SHAFT BEARING BLOCK MOUNTING SCREW NUT	X	X	X	X	X
11	313133	FEED REGULATOR SHAFT ASSEMBLY	X	X	X	X	X
12	313816	FEED REGULATOR SHAFT BUSHING (SELF-ALIGNING) CLAMP	X	X	X	X	X
13	314013-451	FEED REGULATOR SHAFT BUSHING (SELF-ALIGNING) CLAMP SCREW LOCK WASHER	X	X	X	X	X
14	113455-001	FEED REGULATOR SHAFT BUSHING (SELF-ALIGNING) CLAMP SCREW	X	X	X	X	X
15	511030	FEED REGULATOR SLIDE BLOCK	X	X	X	X	X

# ALPHA FEED

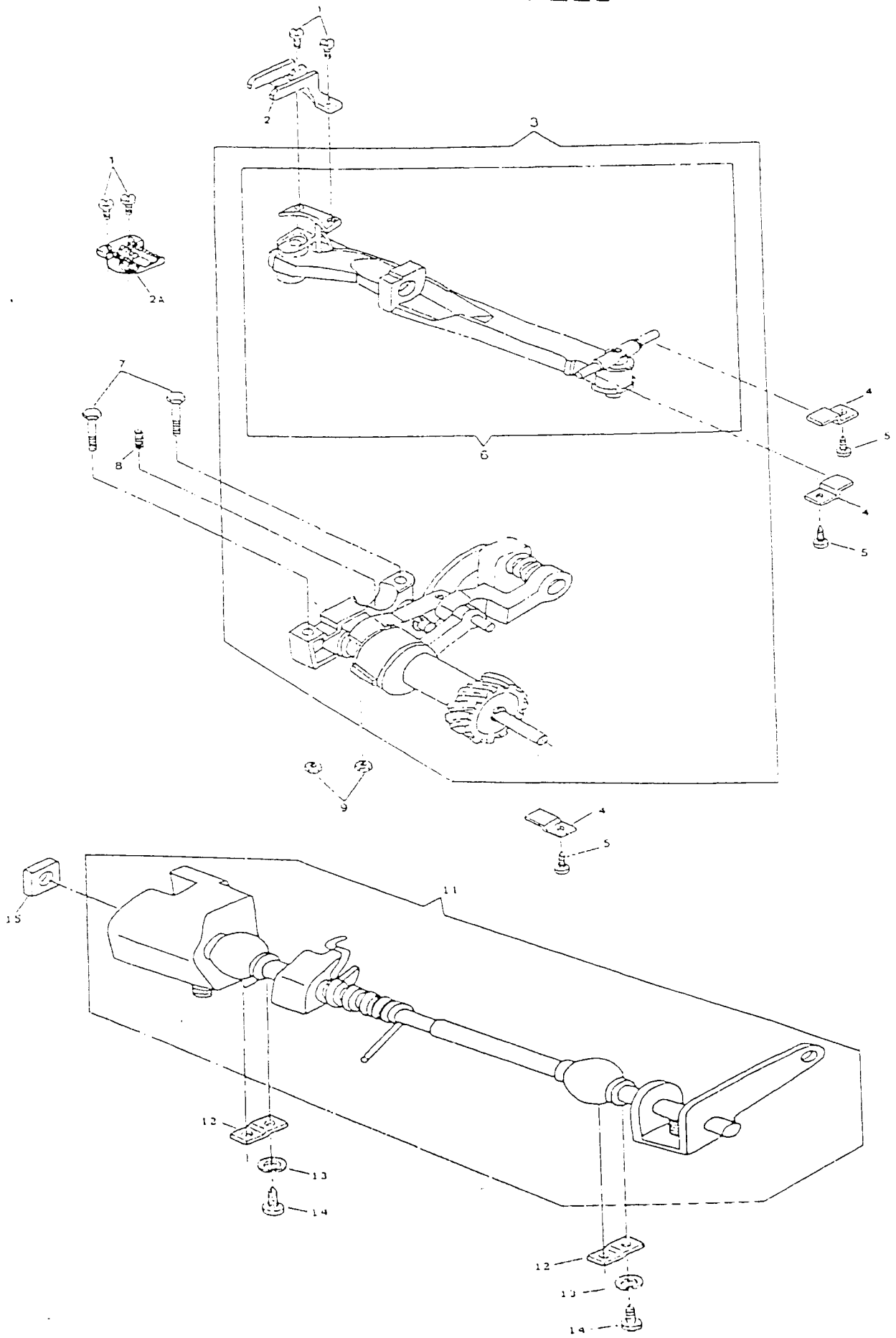

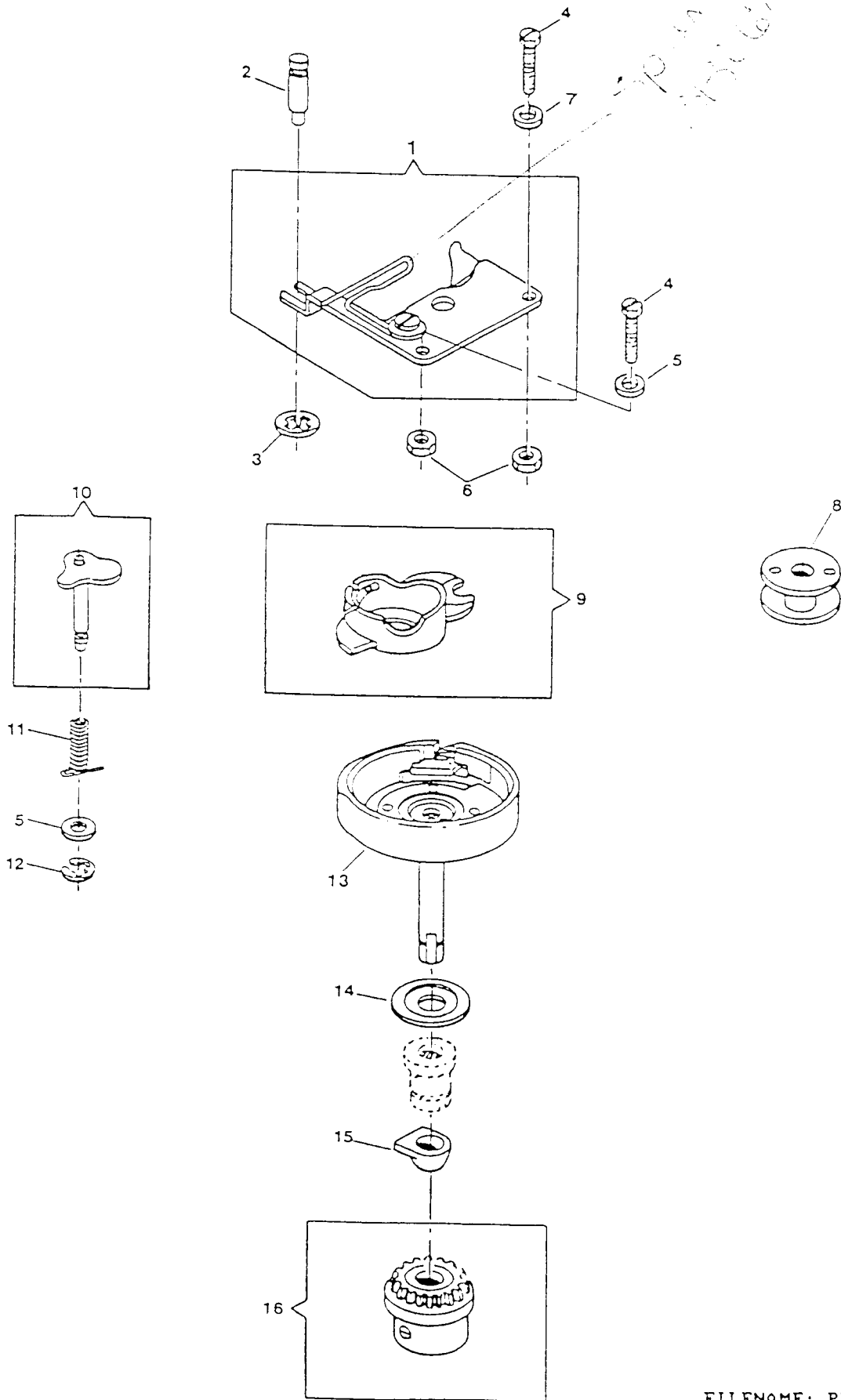

HOOK SYSTEM (APOLLO)  
 MODEL: 9022 9420 9423 9432 9408N304

REF. NO.	PART NO.	DESCRIPTION	9	9	9	9	9N
			0	4	4	4	43
			2	2	2	3	00
			2	0	3	2	84
1	313089	ROTATING HOOK BOBBIN CASE POSITION PLATE ASSEMBLY	X	X	X	X	X
1	314066	ROTATING HOOK BOBBIN CASE POSITION PLATE ASSEMBLY (ALT: 313089)	X	X	X	X	X
2	312603	ROTATING HOOK BOBBIN CASE POSITION PLATE HOLD DOWN STUD	X	X	X	X	X
3	313161	ROTATING HOOK BOBBIN CASE POSITION PLATE HOLD DOWN STUD RETAINER	X	X	X	X	X
4	113439-451	ROTATING HOOK BOBBIN CASE POSITION PLATE SCREW	X	X	X	X	X
5	313190-451	ROTATING HOOK BOBBIN CASE POSITION PLATE SCREW WASHER	X	X	X	X	X
6	313945-451	ROTATING HOOK BOBBIN CASE POSITION PLATE SCREW NUT	X	X	X	X	X
7	446138	ROTATING HOOK BOBBIN CASE POSITION PLATE SCREW WASHER (RIGHT)	X	X	X	X	X
8	172336-001	ROTATING HOOK BOBBIN (PLASTIC)	X	X	X	X	X
9	421325	ROTATING HOOK BOBBIN CASE COMPLETE	X	X	X	X	X
10	312846	ROTATING HOOK BOBBIN CASE RETAINING PLATE SUB-ASSEMBLY	X	X	X	X	X
11	312607	ROTATING HOOK BOBBIN CASE RETAINING PLATE STUD SPRING	X	X	X	X	X
12	313783	ROTATING HOOK BOBBIN CASE RETAINING PLATE STUD RETAINING RING	X	X	X	X	X
13	314025	ROTATING HOOK COMPLETE	X	X	X	X	X
14	314049-001	ROTATING HOOK FLANGED BUSHING THRUST WASHER	X	X	X	X	X
15	312847	ROTATING HOOK FLANGED BUSHING WASHER	X	X	X	X	X
16	314012	ROTATING HOOK BEVEL GEAR COMPLETE	X	X	X	X	X
16	314101-900	ROTATING HOOK BEVEL GEAR COMPLETE (ALT: 314012)	X	X	X	X	X



BLANK PAGE

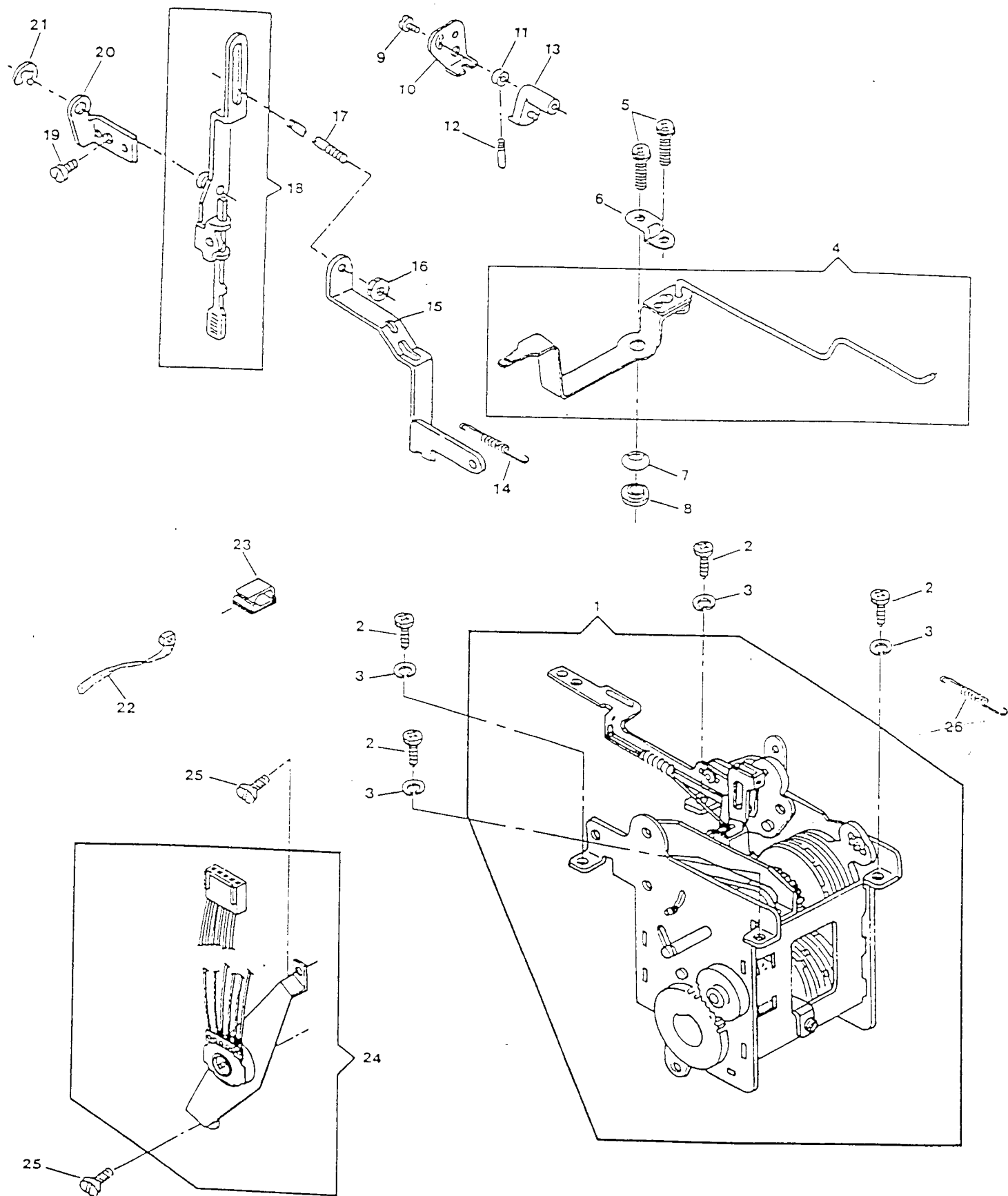

PATTERN, STITCH LENGTH CONTROL AND CAM CONTROLLED FEED  
 MODEL: 9022 9420 9423 9432 9408N304

REF. PART NO.	PART NO.	DESCRIPTION	9	9	9	9	9N
			0	4	4	4	43
			2	2	2	3	00
			2	0	3	2	84
1	314601-001	PATTERN SELECTOR MODULE					
1	314601-002	PATTERN SELECTOR MODULE				X	
1	314601-012	PATTERN SELECTOR MODULE					X
1	317407-001	PATTERN SELECTOR MODULE				X	X
2	113455-001	DISCSELECTOR MECHANISM MOUNTING PLATE SCREW (LEFT AND RIGHT)	X	X	X	X	X
3	314013-451	DISC SELECTOR MECHANISM MOUNTING PLATE SCREW (LEFT AND RIGHT)	X	X	X	X	X
4	314607-003	BIGHT AMPLITUDE CONTROL LEVER ASSEMBLY	X	X	X	X	X
5	113455-014	BIGHT AMPLITUDE CONTROL LEVER STOP ADJUSTMENT SCREW	X	X	X	X	X
6	314683	BIGHT AMPLITUDE CONTROL LEVER RETAINER	X	X	X	X	X
7	353457	BIGHT AMPLITUDE CONTROL LEVER FRICTION WASHER	X	X	X	X	X
8	314611	BIGHT AMPLITUDE CONTROL LEVER SHOULDER WASHER	X	X	X	X	X
26	314497	NEEDLE BAR DRIVING ARM SLIDE POSITIONING SPRING	X	X	X	X	X

PATTERN STITCH LENGTH CONTROL AND CAM CONTROLLED FEED (CONT.)

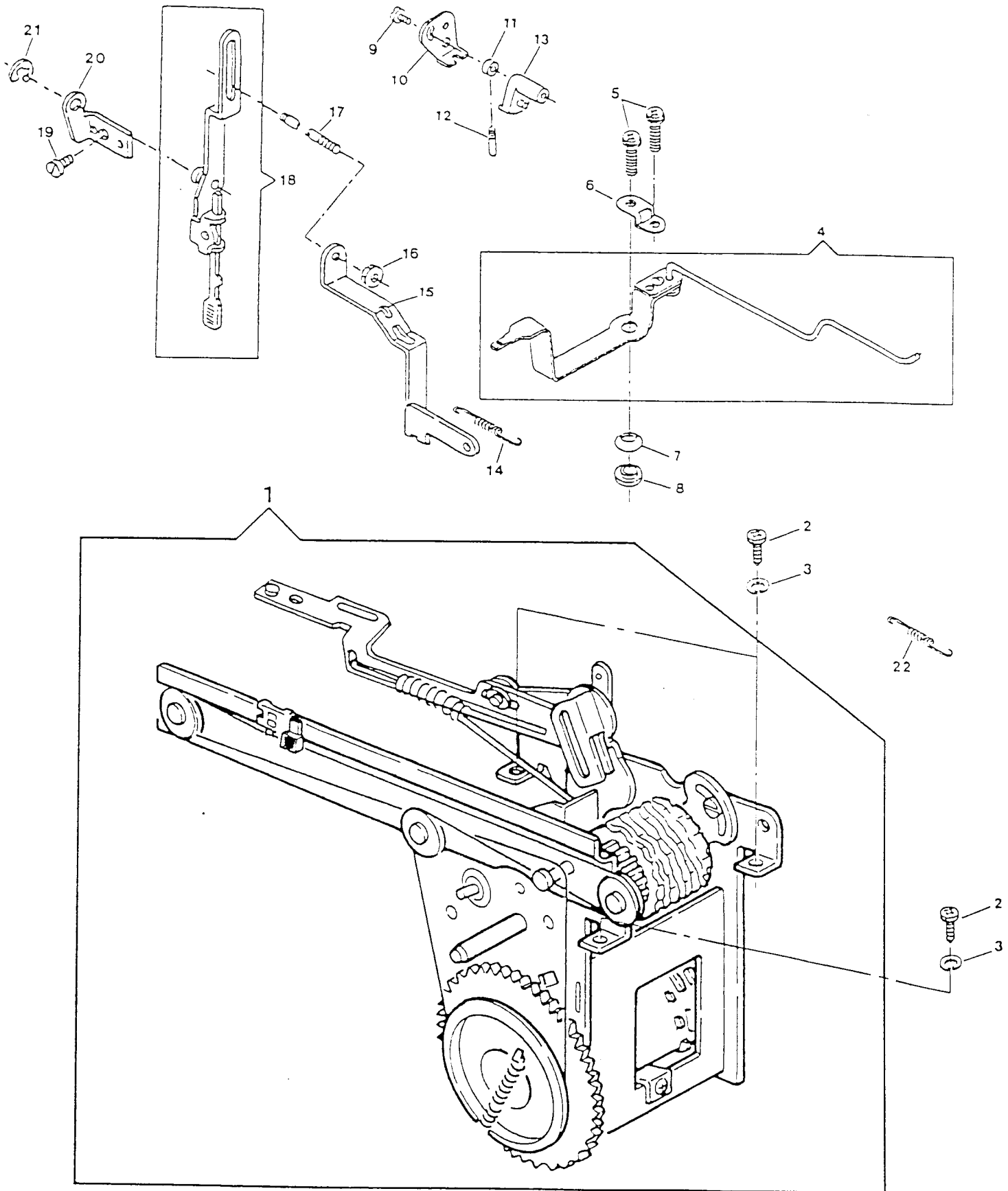

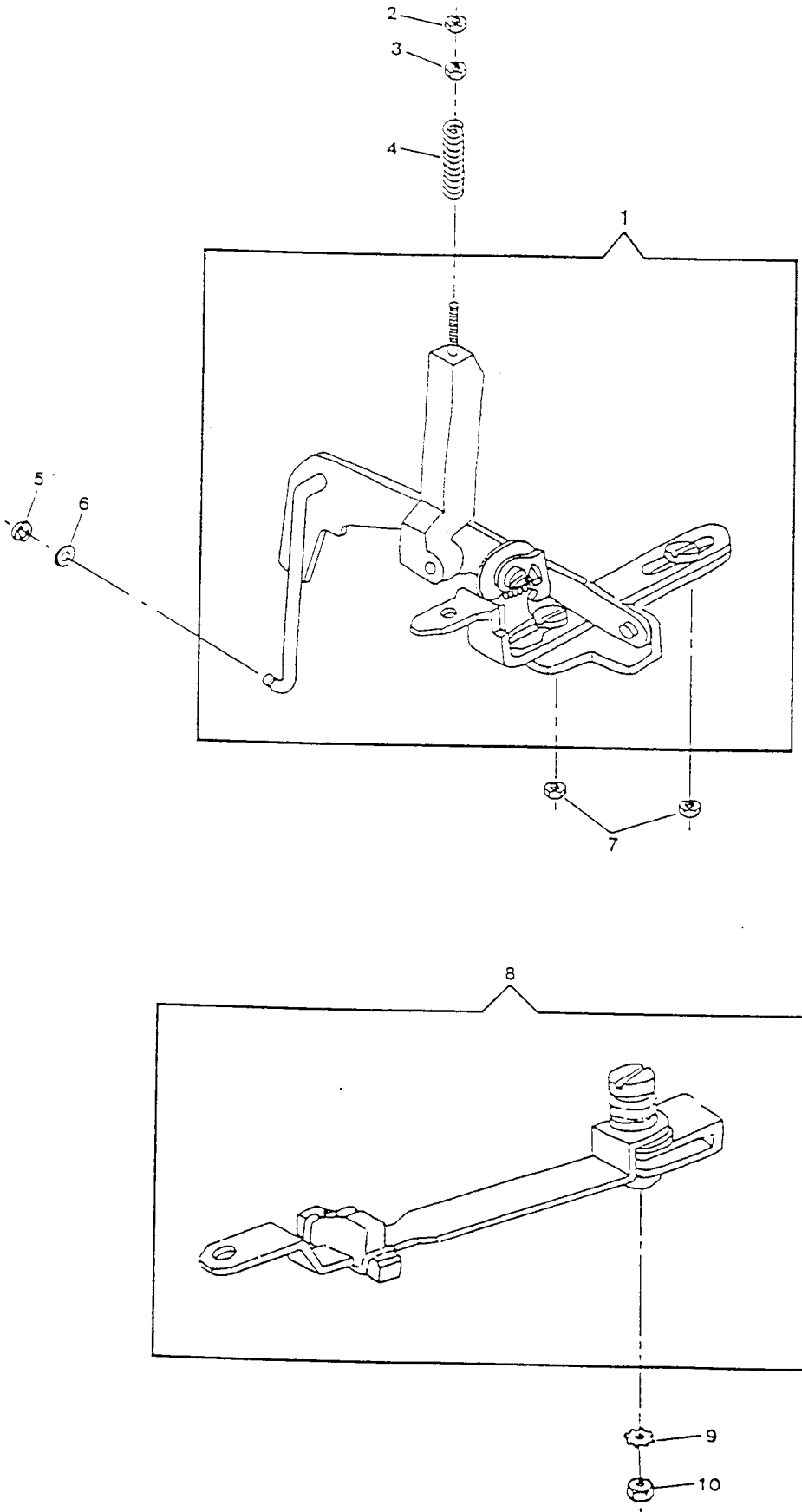

PATTERN, STITCH LENGTH CONTROL & CAM CONTROLLED FEED (CONT.)  
 MODEL: 9022 9420 9423 9432 9408N304

REF. PART NO.	PART NO.	DESCRIPTION	9	9	9	9	9N
			0	4	4	4	43
			2	2	2	3	00
			2	0	3	2	84
1	314300-001	FEED REVERSE MECHANIS	X	X	X	X	X
2	514674-451	CAM CONTROLLED FEED CONNECTING ROD LOCKING NUT	X	X	X	X	X
3	312645-451	CAM CONTROLLED FEED DISC FOLLOWER ACTUATOR CONNECTING ROD ADJUSTING	X	X	X	X	X
4	313143	CAM CONTROLLED FEED DISC FOLLOWER ACTUATOR CONNECTING ROD SPRING	X	X	X	X	X
5	312702	FEED LEVER CONNECTING LINK RETAINING RING	X	X	X	X	X
6	313891	CAM CONTROLLED FEED CONNECTING ROD STABILIZING WASHER	X	X	X	X	X
7	514674-451	REVERSE FEED CONTROL LEVER GUIDE SCREW NUT	X	X	X	X	X
8	313569	STITCH LENGTH CONTROL LEVER ASSEMBLY	X	X	X	X	X
9	313172-451	STITCH LENGTH CONTROL LEVER PIVOT LOCK WASHER	X	X	X	X	X
10	313177-451	STITCH LENGTH CONTROL LEVER NUT	X	X	X	X	X

DEMAND RESPONSIVE NEEDLE TENSION SYSTEM  
 MODEL: 9022 9420 9423 9432 9408N304

REF. PART NO.	PART NO.	DESCRIPTION	9	9	9	9	9N
			0	4	4	4	43
			2	2	2	3	00
			2	0	3	2	84
1A	317383-900	THREAD TENSION MODULE	X	X	X	X	
1A	317383-950	THREAD TENSION MODULE	X		X	X	
1A	317383-951	THREAD TENSION MODULE					X
2	313199	TENSION COVER MOUNTING RETAINER	X	X	X	X	X
3	313047	TENSION COVER RETAINING CLIP	X	X	X	X	X

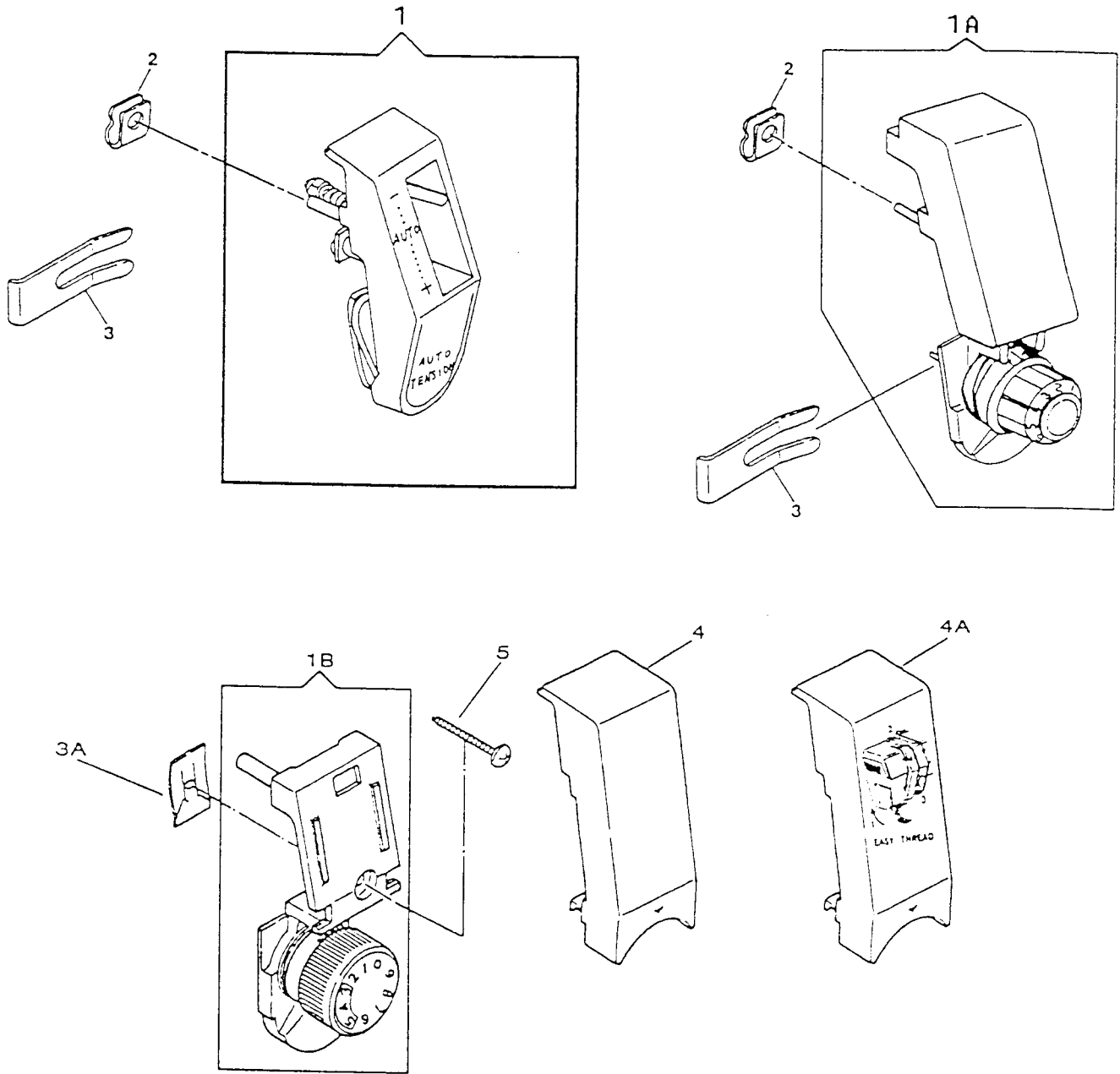



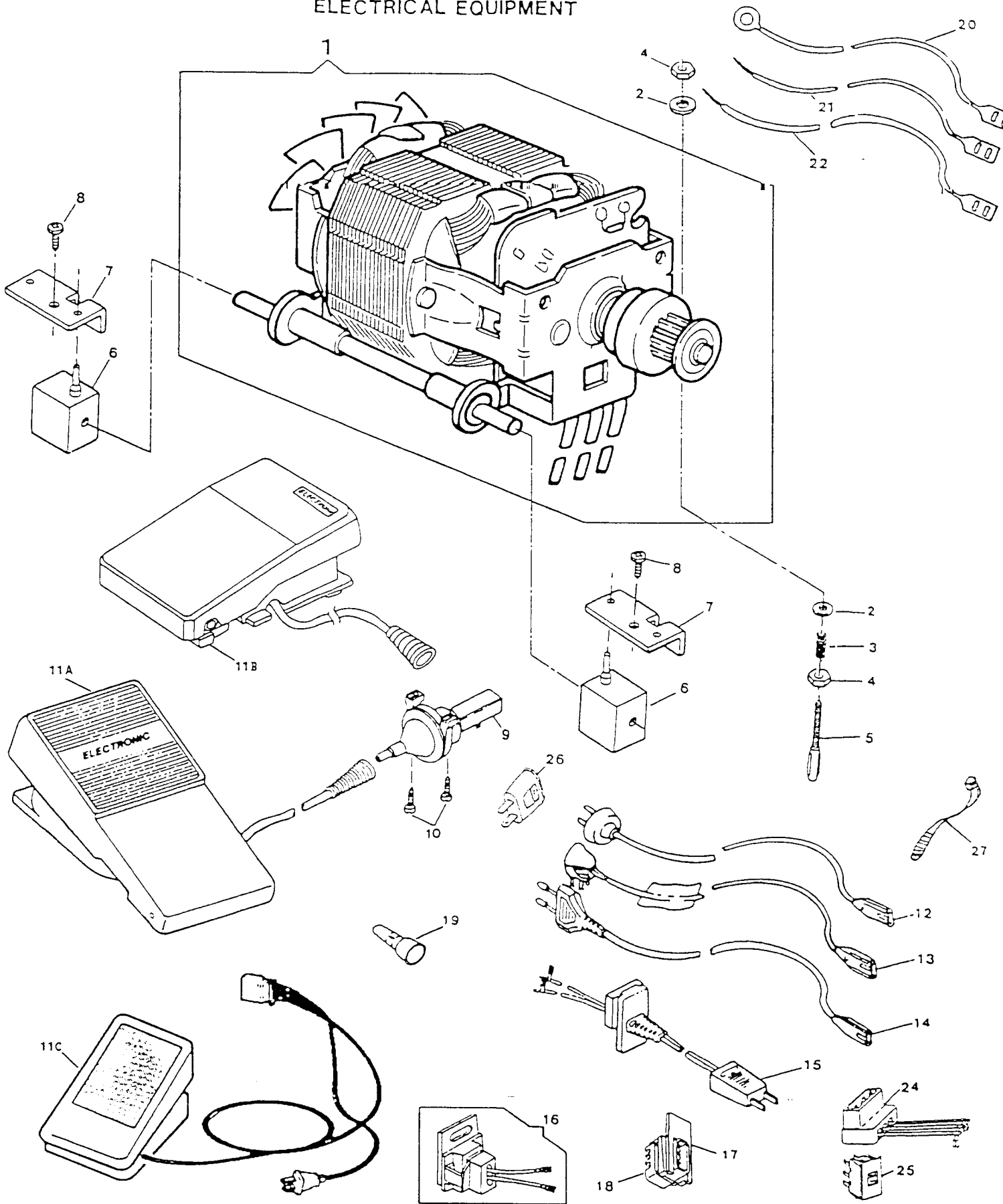

ELECTRICAL EQUIPMENT  
MODEL: 9022 9420 9423 9432 9408N304

REF. PART NO.	NO.	DESCRIPTION	9	9	9	9	9N
			0	4	4	4	43
			2	2	2	3	00
			2	0	3	2	84
1	317279-001	MOTOR COMPLETE (DUAL VOLTAGE FOR U.S.A./KOREA/GERMANY & H.K.)					X X
1	317352	MOTOR COMPLETE (120V CARBON PILE)	X	X	X	X	
1	317427-001	MOTOR COMPLETE (240V CARBON PILE)(7028N304)	X	X	X	X	X
1	317436	MOTOR COMPLETE (230V CARBON PILE)(7028N305)	X	X	X	X	
2	37969	MOTOR ADJUSTING STUD NUT WASHER	X	X	X	X	X
3	314058	MOTOR BELT TENSION SPRING	X	X	X	X	X
4	53646	MOTOR ADJUSTING STUD NUT	X	X	X	X	X
5	988653-001	MOTOR ADJUSTING STUD	X	X	X	X	X
6	979329-001	RESILIENT MOUNT	X	X	X	X	X
7	988651-001	CLIP	X	X	X	X	X
8	113470-004	MOTOR MOUNTING SCREW	X	X	X	X	X
11C	137904	FOOT CONTROLLER W/PLUG ASSEMBLY (240V, UK)	X	X	X	X	X
11C	317281-001	CARBON PILE FOOT CONTROLLER ASS'Y (230V EUROPE)	X	X	X	X	X
11C	317281-002	CARBON PILE FOOT CONTROLLER ASSEMBLY (240V) (UK)	X	X	X	X	
11C	317281-003	CARBON PILE FOOT CONTROLLER ASSEMBLY (240V, AUST)	X	X	X	X	
11C	317281-006	CARBON PILE CONTROLLER ASSEMBLY (FOR ALL TERRITORIES EXCEPT: AUST., HK, EUROPE & SCAND.)	X	X	X	X	X
11C	317281-007	CARBON PILE FOOT CONTROLLER ASSEMBLY (FOR SCAN.)	X	X	X	X	
11C	<u>317353-001</u>	CARBON PILE FOOT CONTROLLER ASSEMBLY (120V, UL)	X	X	X	X	
11C	317353-002	CARBON PILE FOOT CONTROLLER ASSEMBLY (120V FOR CSA)	X	X	X	X	
11C	<del>317353-003</del>	CARBON PILE FOOT CONTROLLER ASSEMBLY (U.S./CANADA) (SPT-2)	X	X	X	X	
11C	<del>319003-003</del>	<u>TRIAC FOOT CONTROLLER ASSEMBLY</u>	X	X	X	X	
11C	319003-005	TRIAC FOOT CONTROLLER (DUAL VOLTAGE) (FOR U.S.A.)	X	X	X	X	X
13	137902	POWER PLUG WITH CORD ASS'Y (240V FOR U.K.)	X	X	X	X	X
17	317282-901	HOLDER (220/240V) (DUAL VOLTAGE FOR U.S.A./KOREA/GERMANY & H.K.)	X	X	X	X	X
18	317428-900	RECEPTACLE (220/240V)(FOR 9008N304)	X	X	X	X	X
19	317355	WIRE CONNECTOR	X	X	X	X	X
20	317356-001	LEAD (A) W/TERMINAL ASSEMBLY (120V)	X	X	X	X	
21	317356-002	LEAD (B) W/TERMINAL ASSEMBLY (120V)	X	X	X	X	
22	317356-003	LEAD W/TERMINAL ASSEMBLY (230/240V)	X	X	X	X	X
24	317283-001	RECEPTACLE W/LEAD ASS'Y (DUAL VOLTAGE FOR U.S.A/KOREA/GERMANY & H.K.)					X X
25	317284-901	VOLTAGE SELECTOR SWIETH (DUAL VOLTAGE FOR U.S.A/ KOREA/ GERMANY & H.K.)					X X
26	137547	ADAPTOR (DUAL VOLTAGE FOR U.S.A. /KOREA/ GERMANY & H.K.)					X X
27	540899	TY-WRAP SELF-LOCKING (DUAL-VOLTAGE FOR U.S.A./ KOREA/ GERMANY & H.K.)					X X

ELECTRICAL EQUIPMENT (CONT.)  
 MODEL: 9022 9420 9423 9432 9408N304

REF. PART NO.	PART NO.	DESCRIPTION	9	9	9	9	9M
			0	4	4	4	43
			2	2	2	3	00
			2	0	3	2	S4
1A	314823-001	LINT AND HEAT SHIELD ASSEMBLY (230/240V) (FOR 9008N304)	X	X	X	X	X
1B	314823-003	LINT AND HEAD SHIELD ASSEMBLY (120V)	X	X	X	X	
2A	317439	LAMP SOCKET (230/240V) (FOR 9008N304)	X	X	X	X	X
3	540899	TY-WRAP SELF-LOCKING (ALT:605600-001)	X	X	X	X	X
4A	317397-902	LAMP SOCKET ASSEMBLY (120V, DOUBLE INSULATION)	X	X	X	X	
5	113455-003	THREAD TAKE-UP COVER AND LING/HEAT SHIELD SCREW	X	X	X	X	X
7	137813-002	SCREW, LINT AND HEAT SHIELD MOUNTING	X	X	X	X	X
8	194120-019	LIGHT BULB (120V) (ALT: 542656-005) (DUAL VOLTAGE FOR U.S.A./KOREA/GERMANY & H.K.)	X	X	X	X	
8	194120-020	LIGHT BULB (230V) (ALT:542656-003) (FOR 9008N304)	X	X	X	X	X
8	194120-021	LIGHT BULB (240V) (ALT:542656-004)	X	X	X	X	
10	979585-911	ROCKER SWITCH	X	X	X	X	X

