

SINGER

8734/8834

RECEIVED
FEB 24 1935
ORDER ENTER

List of Parts

Sewing Machine

8734

same as
8834

contents

	PAGE
1. TOP COVER	
BACK and SIDES COVERS	2
2. MACHINE BASE and CLOTH PLATE	4
3. NEEDLE BAR and DRIVE MECHANISM	6
4. NEEDLE HOOK and PLATES	8
5. PRESSURE BAR and TENSION	10
6. FEED and HOOK DRIVE MECHANISM (Tubular Bed)	12
7. BUTTONHOLER, FEED REGULATOR and CAM CONTROL FEED ENGAGING MECHANISM	14
8. CAM CONTROL FEED and STITCH BALANCING MECHANISM	16
9. BIGHT AMPLITUDE and NEEDLE POSITION SELECTORS	18
10. CAM STACK	
PATTERN SELECTOR	20
11. ATTACHMENTS	22
12. ELECTRICS	24

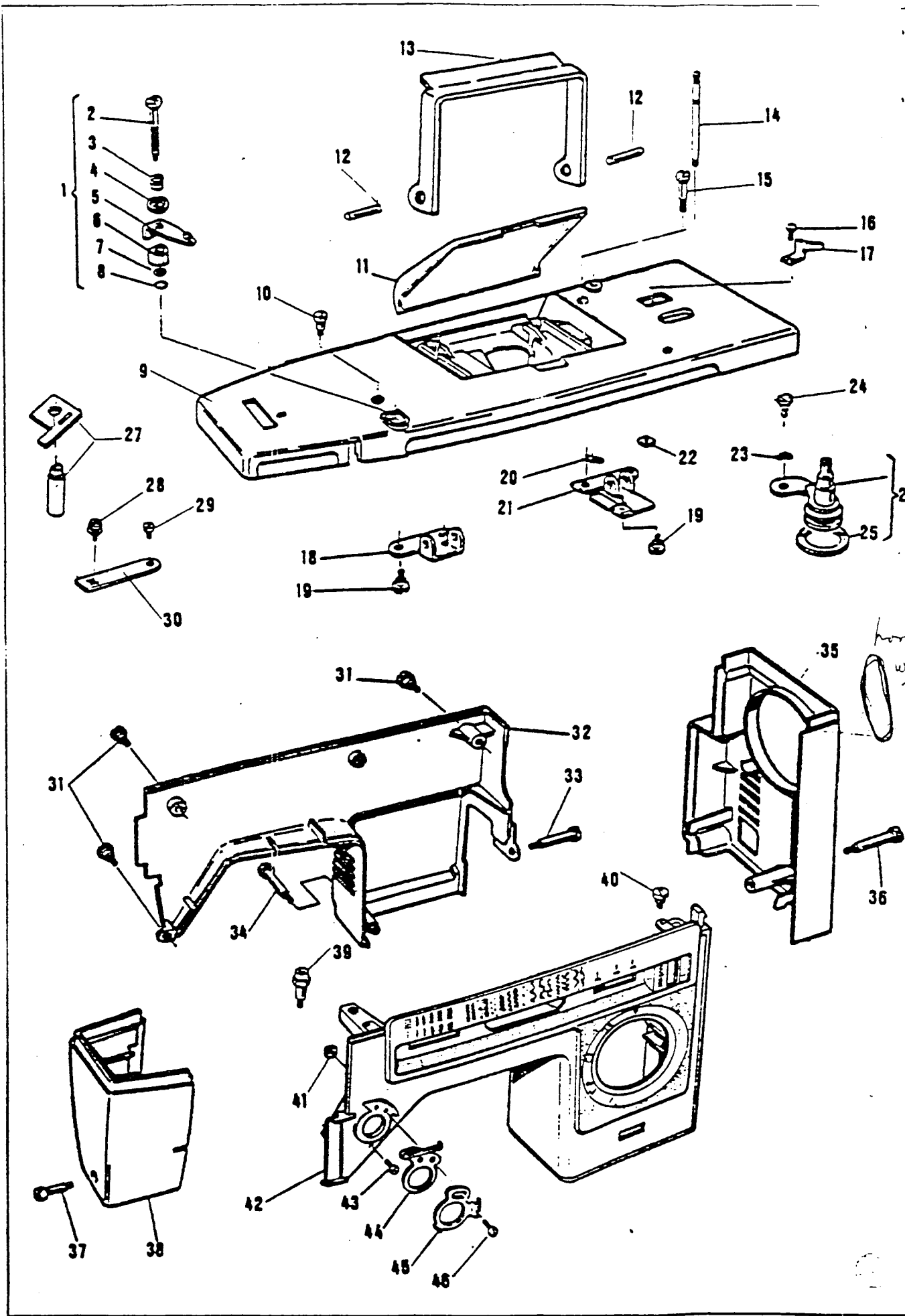

1 - TOP COVER, BACK AND SIDES COVERS

REF. N.	PART. N.	PART DESCRIPTION
1	352515-455	BOBBIN WINDER TENSION CPL.
2	44751	BOBBIN WINDER TENSION STUD
3	45847	TENSION DISC SPRING
4	45913	TENSION DISC
5	319717	TENSION BRACKET AND THREAD GUIDE
6	44770-461	TENSION BRACKET SPACER
7	352737	TENSION STUD WASHER
8	44447	TENSION STUD RETAINING RING
9	447514-901	ARM TOP COVER
10	421720	ARM TOP COVER SCREW (LEFT)
11	447506-452	ARM TOP COVER LID ASSEMBLY
12	447503	MACHINE HANDLE HINGE PIN
13	447502-000	MACHINE HANDLE
14	44998-452	ARM TOP COVER SPOOL PIN (RETRACTABLE)
15	141788	ARM TOP COVER SCREW (RIGHT)
16	141808	BOBBIN WINDER STOP SCREW
17	44365	BOBBIN WINDER STOP
18	352927	MACHINE HANDLE MOUNTING BRACKET (LEFT)
19	113418-451	SCREW
20	45000	ARM TOP COVER SPOOL PIN RETAINING
21	352929	MACHINE HANDLE MOUNTING BRACKET
22	53640	BOBBIN WINDER STOP SCREW NUT
23	353457	HINGE SCREW WASHER
24	422025-451	HINGE SCREW
25	15287-701	FRICTION RING
26	421960	BOBBIN WINDER CPL.
27	447522	NEEDLE STOP PLATE ASSEMBLY
28	514733-451	SCREW
29	113367-451	SCREW
30	447555	HANDLE RETAINING PLATE
31	139910	ARM COVER (BACK) SCREW (3)
32	421652-452	ARM COVER (BACK)
33	354659-451	ARM COVER (BACK AND FRONT) SCREW
34	354252-451	ARM COVER (BACK) SCREW
35	421654-452	ARM COVER HAND WHEEL SIDE
36	354655-451	ARM COVER HAND WHEEL SIDE SCREW
37	514727-451	FACE PLATE SCREW
38	447881-451	FACE PLATE
39	421719-451	ARM FRONT COVER SCREW (UPPER, LEFT)
40	421720	ARM FRONT COVER SCREW (UPPER, RIGHT)
41	53640	NUT
42	447885-451	ARM FRONT COVER CPL.
43	141808	ARM FRONT COVER SCREW (LOWER, LEFT)
44	446958	THREAD GUIDE (UPPER)
45	44392	TENSION THREAD GUIDE
46	141808	SCREW
	353467-454	Hand wheel

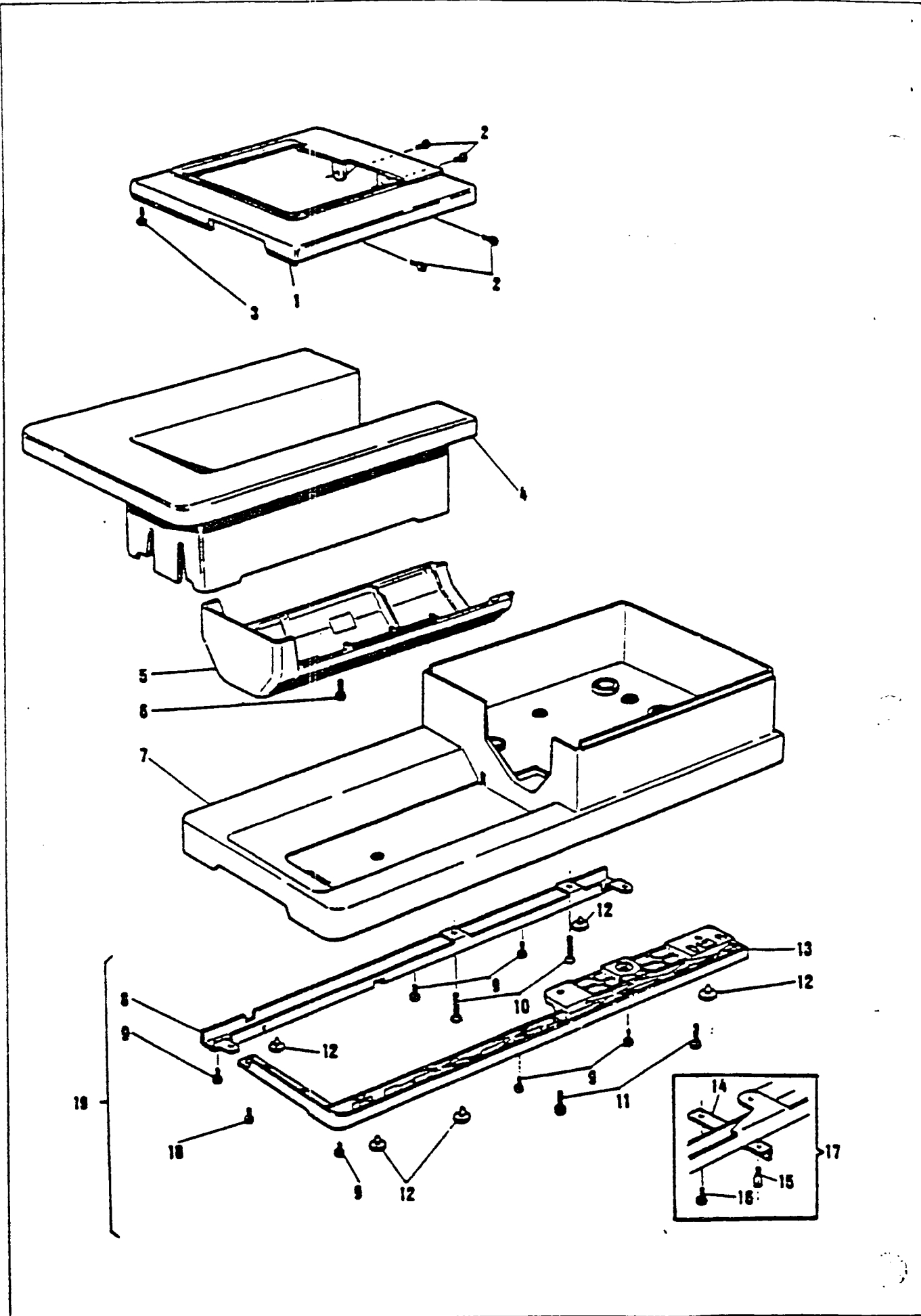

2 - MACHINE BASE AND CLOTH PLATE

REF. N.	PART. N.	PART DESCRIPTION
1	421656-454	Bed cover
2	139910	Bed cover screw (4)
3	139984	Bed cover screw (1)
4	421657-454	Cloth plate <i>NLA</i>
5	352839-454	Bed cover (tubular)
6	514690-451	Bed cover (tubular) screw
7	421655-454	Machine base
8	421660	Machine base support back
9	354738-451	Machine support (back and front) screw (8)
10	354790-451	Base support (back) screw (2)
11	354745-451	Base support (front) screw (2)
12	352797	Machine base cushion (3)
13	421736	Machine base support
14	352795	Bracket (<u>for cabinets only</u>)
15	422481-451	Cushion (<u>for cabinets only</u>)
16	354745-451	Bracket screw (<u>for cabinets only</u>)
17	353035	Kit cpl. (<u>for cabinets only</u>)
18	421712	Screw
19	422010-455	Machine base cpl.

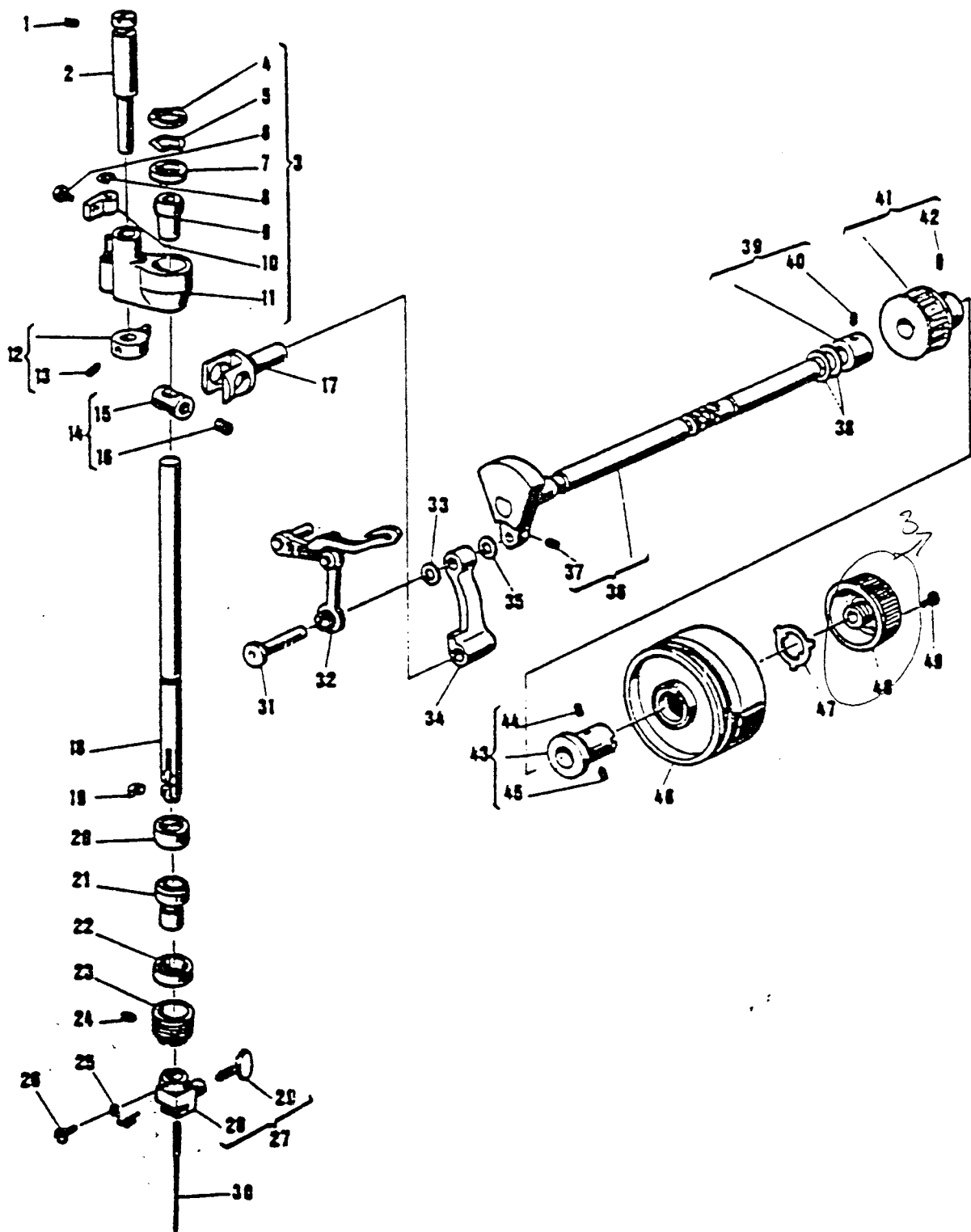

REF. N.	PART. N.	PART DESCRIPTION
1	141918	Screw
2	445124	Hinge pin eccentric
3	422318	Needle bar vibrating bracket cpl.
4	422320	Retaining ring
5	502354	Washer
6	354621-451	Screw
7	507379	Ball bushing (upper) socket
8	507343	Retaining ring
9	37927	Ball bushing (upper)
10	37934	Bracket
11	422404	Vibrating bracket with hinge pin
12	44673	Hinge pin (eccentric) collar
13	141940	Set screw
14	37932	Needle bar connecting stud hinge pin cpl.
15	37931	Needle bar connecting stud hinge pin
16	141916	Set screw
17	37930	Needle bar connecting stud
18	352912	Needle bar
19	37943	Needle bar glb
20	44450	Ball bushing (lower) socket (upper)
21	37927	Ball bushing (lower)
22	507379	Ball bushing (lower) socket (lower)
23	44473	Ball bushing (lower) adjusting screw
24	141803	Set screw
25	319721	Needle clamp thread guide
26	141808	Screw
27	319729 -	Needle clamp cpl.
28	319728	Needle clamp body
29	511171	Needle thumb screw
30	Cat. 2045	Needle size 14 (fitted on machine)
31	422310	Thread take-up stud
32	422307	Thread take-up
33	421356	Washer
34	352753	Needle bar connecting link
35	352754	Washer
36	352573	Arm shaft
37	354105	Thread take-up crank set screw
38	319764	Washer (2)
39	353357	Arm shaft retaining collar cpl.
40	141916	Set screw
41	353239	Arm shaft belt drive pulley cpl.
42	141918	Arm shaft belt drive pulley set screw
43	44679	Clamp stop motion flanged bushing cpl.
44	141916	Set screw
45	141915	Flanged bushing positioning screw
46	353107-454	Hand wheel
47	44464	Clamp stop motion clamp washer
48	352589-454	Clamp stop motion clamp screw = 352-589-452
49	141914	Clamp stop motion clamp stop screw

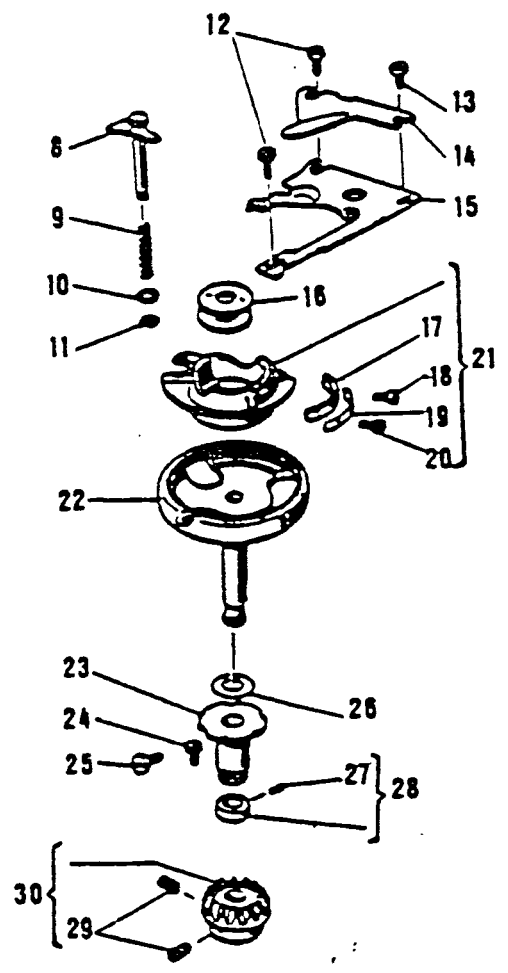
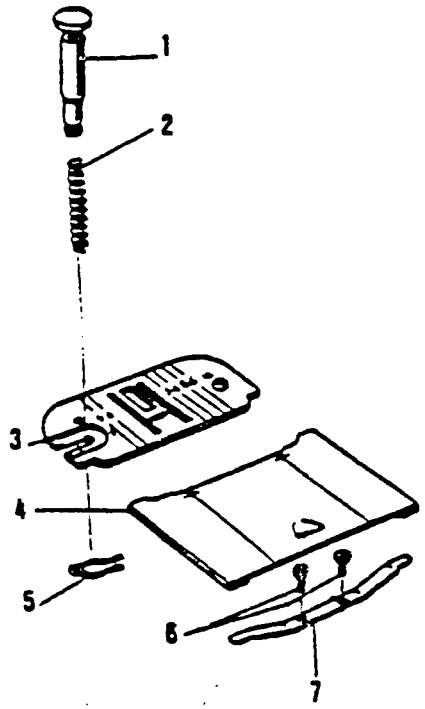

4 - NEEDLE HOOD AND PLATES

REF. N.	PART. N.	PART DESCRIPTION
1	102840	NEEDLE PLATE CLAMP
2	153930	NEEDLE PLATE CLAMP SPRING
3	312391	NEEDLE PLATE
4	422229	BED SLIDE
5	179658	CLIP
6	354134	BED SLIDE SPRING SCREW (2)
7	103344	BED SLIDE SPRING
8	422129	RETAINING PLATE
9	319735	SPRING
10	319737-451	WASHER
11	319736	CLIP
12	354229-451	POSITION PLATE SCREW (2)
13	354227-451	POSITION PLATE SCREW
14	381903	RETAINING PLATE (ADJUSTABLE)
15	44873	POSITION PLATE
16	172336	BOBBIN
17	310884-452	TENSION SPRING SEGMENT
18	139975	TENSION SPRING SEGMENT SCREW
19	310883	TENSION SPRING
20	354183-451	TENSION REGULATING SCREW
21	421325	BOBBIN CASE CPL.
22	353104	ROTATING HOOK
23	353237	FLANGED BUSHING (ECCENTRIC)
24	354133-451	POSITION SCREW
25	514689-451	BUSHING SET SCREW
26	506164	WASHER
27	114312	COLLAR SET SCREW
28	116084	ROTATING HOOK COLLAR
29	514721	BEVEL GEAR SET SCREW (2)
30	103361-001	BEVEL GEAR CPL.

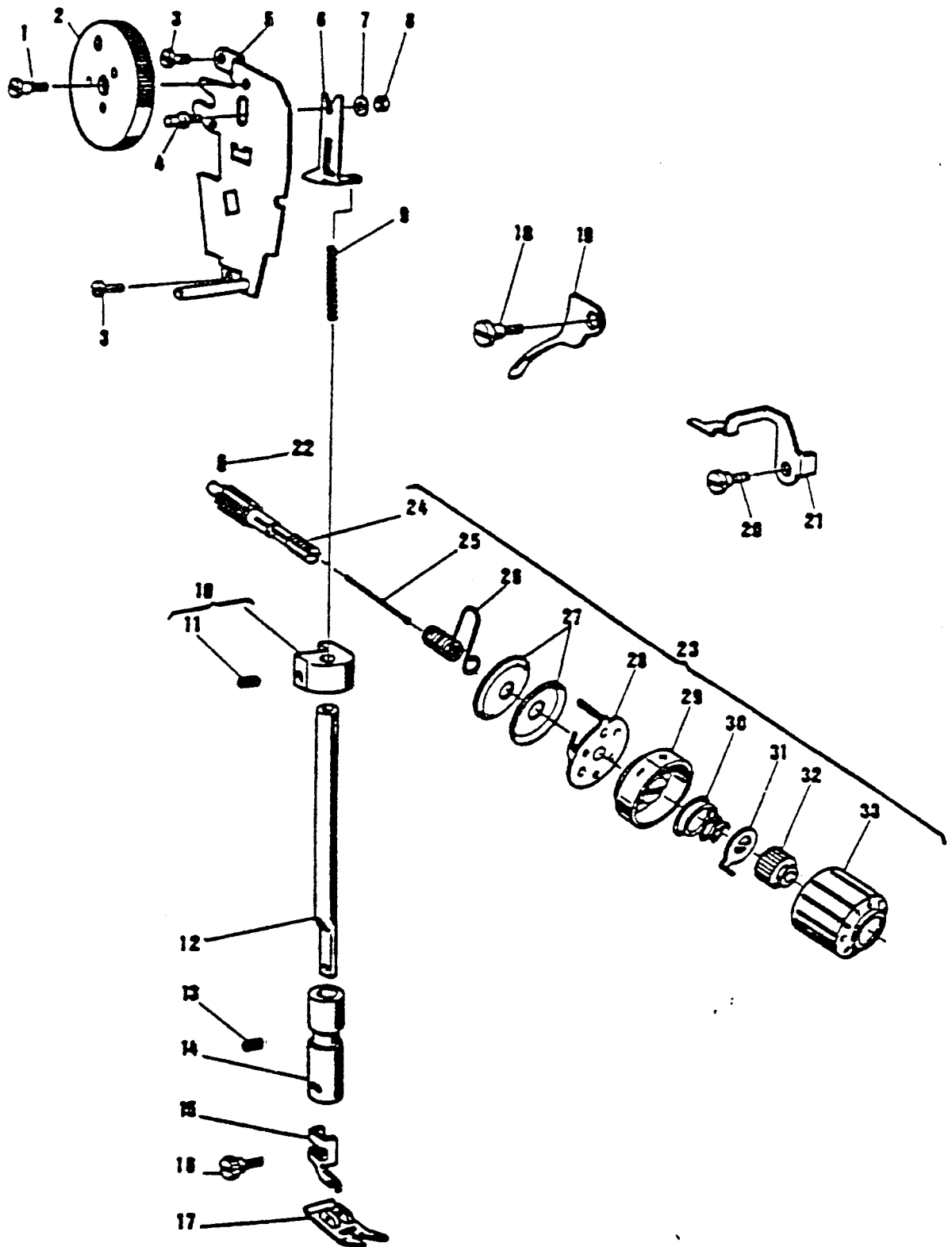

3 - PRESSURE BAR AND TENSION

REF. N.	PART. N.	PART DESCRIPTION
1	141941	Pressure knob screw
2	421717-452	Pressure regulating knob
3	141913	Bracket screw (2)
4	422317	Pressure regulating knob pin
5	422313	Pressure regulating knob bracket
6	422316	Pressure regulating knob bracket slide
7	422241	Washer
8	514674	Nut
9	44449	Presser bar spring
10	44444	Presser bar guide bracket cpl.
11	354420-451	Set screw
12	446740	Presser bar
13	141803	Bushing set screw
14	37958	Presser bar bushing
15	155964	Presser bar shank
16	354135-451	Presser foot thumb screw
17	155962 <i>MSC</i>	Presser foot (zig-zag)
18	141846	Hinge screw
19	44445	Presser bar lifter
20	141786	Hinge screw
21	44829	Tension releasing lever
22	141803	Set screw
23	422403-459	Tension cpl. = 422403-457
24	44454	Tension stud
25	37986	Tension releasing pin
26	66774-002	Thread take-up spring
27	2102	Tension disc (2)
28	45343	Spring thread guard
29	421739-451	Tension spring cup
30	125314	Tension spring
31	37984	Tension indicator stop washer
32	507405	Tension indicator adaptor
33	422402-451	Tension indicator

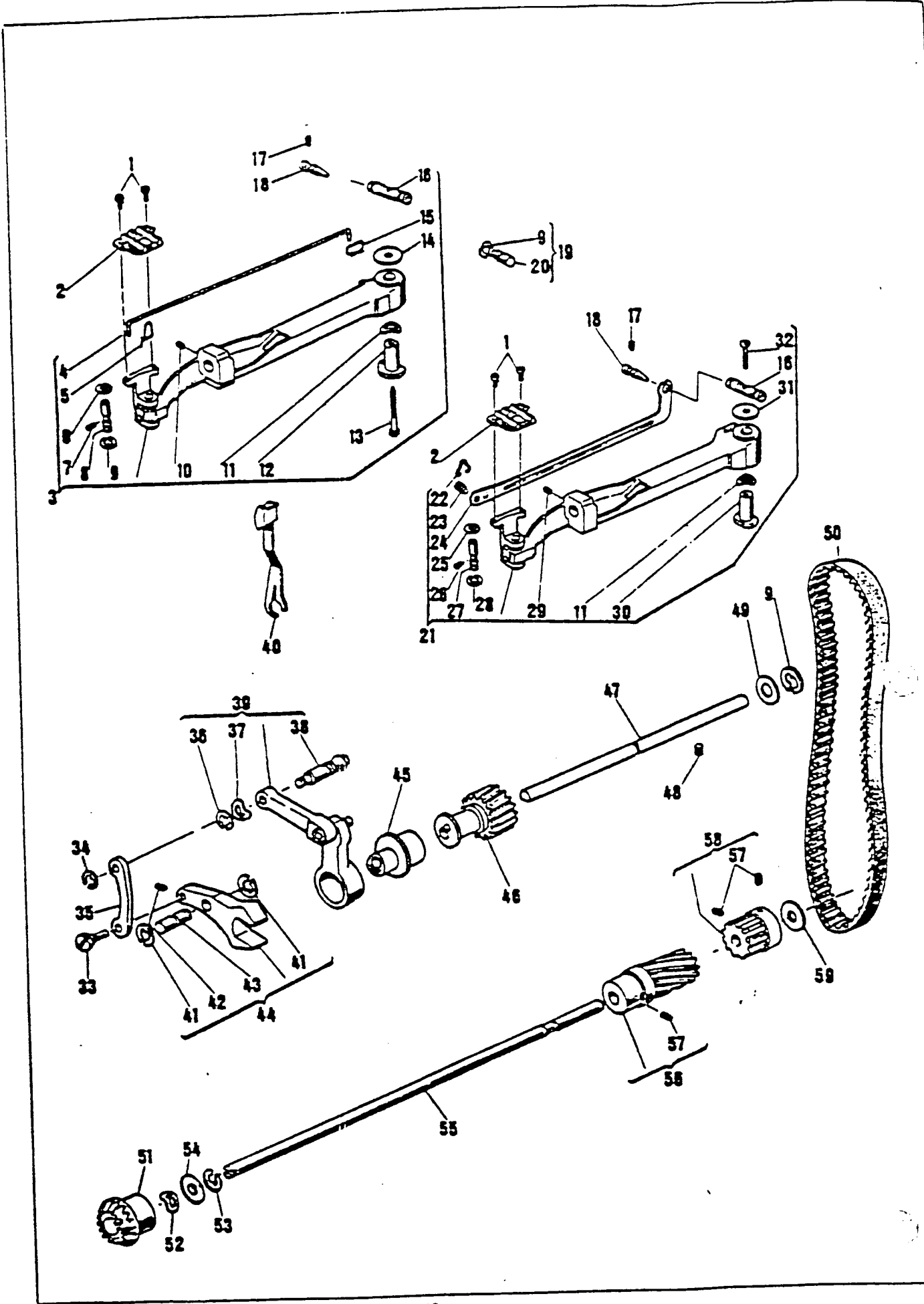

3 - FEED LIFT HOOK DRIVE MECHANISM

REF. N.	PART. N.	PART DESCRIPTION
1	141920	Feed dog screw (2)
2	422406	Feed dog
3	422385	Feed bar cpl.
4	422335-000	Compensating link
5	422561-000	Retaining spring
6	511210	Washer
7	544100	Screw
8	511052	Stud
9	511213	Retaining ring
10	549308	Set screw
11	511211	Washer
12	422340	Bushing
13	514744-451	Feed bar guide pin screw
14	422338	Washer
15	422337-000	Retaining spring
16	421814	Feed bar guide pin
17	514556-451	Set screw
18	507917	Feed bar guide pin centre (black)
19	502310	Feed bar guide pin centre cpl. (front)
20	502309	Feed bar guide pin centre (front)
21	353195	Feed bar cpl. (Alternate To 422385)
22	511075	Retaining spring
23	141827	Screw stud
24	174216	Compensating link
25	174251	Washer
26	139878	Screw
27	174217	Stud
28	163562	Retaining ring
29	141812	Set screw
30	507822	Bushing
31	507824	Washer
32	514692	Feed bar guide pin screw
33	511056	Hinge stud (eccentric)
34	507063	Retaining ring
35	511016	Feed lifting fork connection
36	502744	Retaining ring
37	422368	Washer
38	422345	Hinge stud (eccentric)
39	422347	Drive connection
40	421875	Belt tension adjuster lever
41	511213	Retaining ring
42	514685	Set screw
43	511057	Hinge stud
44	422514	Feed lifting fork cpl.
45	422361	Feed eccentric
46	422325	Feed drive shaft gear cpl.
47	422324	Feed drive shaft
48	514556	Set screw
49	116073	Drive shaft washer
50	421035-001	Drive shaft belt
51	422395	Drive shaft bevel gear
52	507722	Rotating hook drive shaft spring washer
53	511213	Retaining ring
54	116073	Drive shaft washer
55	422394	Rotating hook drive shaft
56	422408	Drive shaft gear cpl.
57	514556	Set screw
58	352871	Drive shaft gear
59	421356	Damping washer

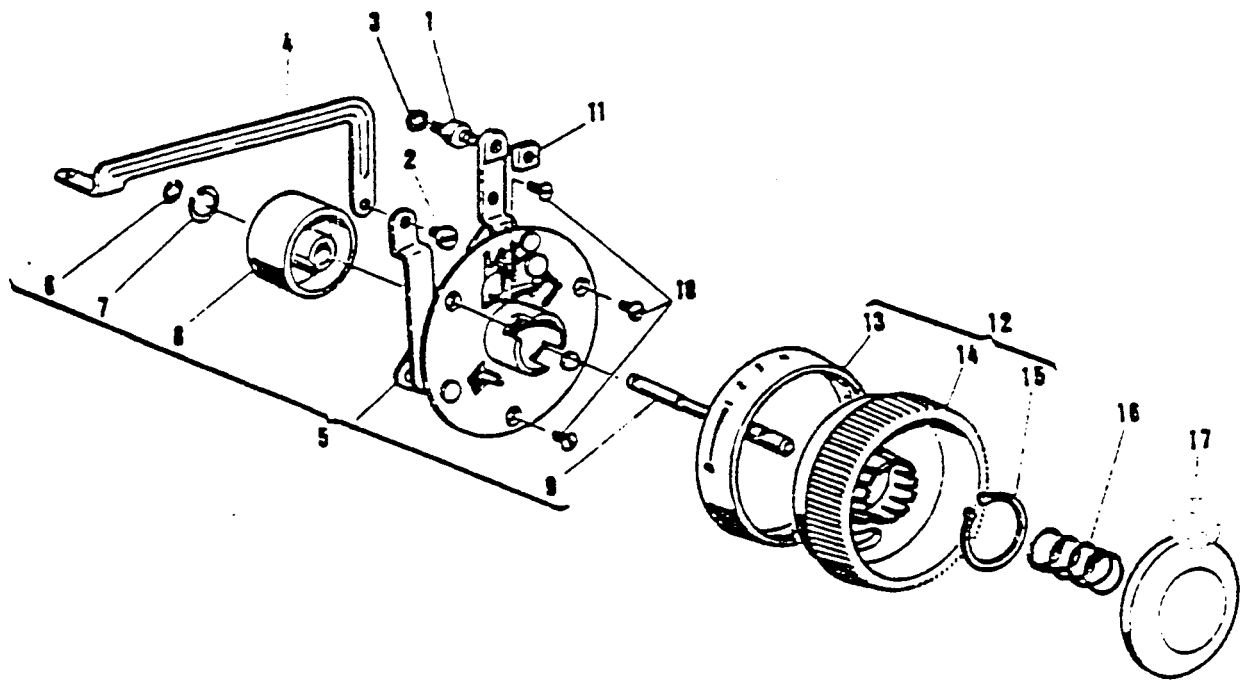

REF. N.	PART. N.	PART DESCRIPTION
1	514748	Bearing screw
2	139866	Hinge screw
3	507063	Retaining ring
4	421926	Sight control lever link
5	422363	Buttonhole and feed regulator cpl.
6	507063	Retaining ring
7	421925	Retaining ring
8	421852	Feed regulator cam
9	421935	Reverse feed pin
10	139868	Screw
11	514698-451	Nut
12	422021-459	Control dial cpl.
13	421938-459	Control dial ring
14	421862-45A	Control dial
15	421871	Retaining ring
16	421934	Pressure spring
17	421933-45A	Reverse feed push button ✓

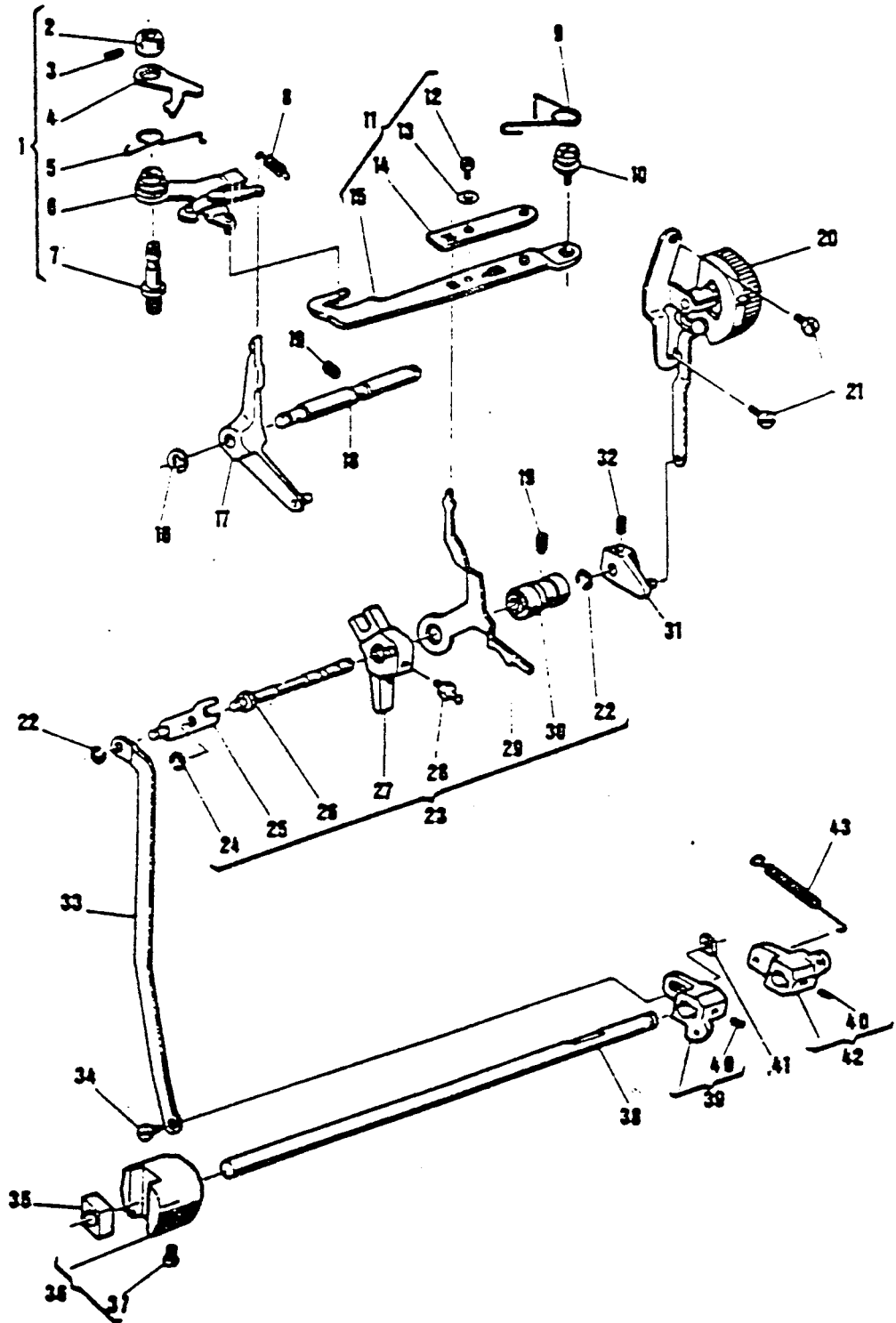

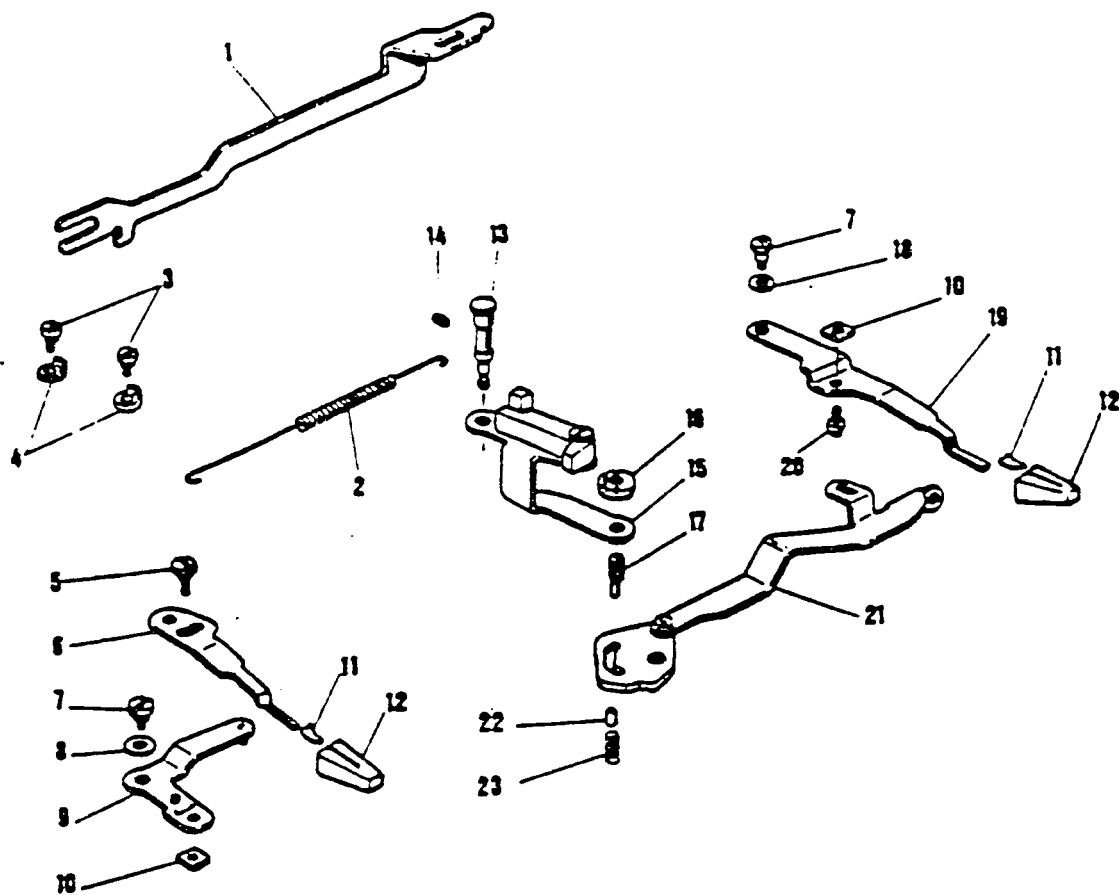

3 - BIGHT AMPLITUDE AND NEEDLE POSITION SELECTORS

REF. N.	PART. N.	PART DESCRIPTION
1	37933	Needle bar driving arm
2	37942	Tension spring
3	141787	Stop screw (2)
4	37244	Control lever link stop (2)
5	514730-451	Screw
6	421850	Bight amplitude control lever
7	141786	Hinge screw
8	49204	Friction washer
9	421984	Control lever link
10	514707-451	Nut
11	37244	Control lever knob spring clip
12	421860-454	Control lever knob
13	37941	Hinge stud
14	354196-451	Set screw
15	421886	Slide bracket
16	179739-451	Eccentric screw stud nut
17	445347	Eccentric screw stud
18	49204	Friction washer
19	421859	Needle position lever
20	421893	Stud
21	421859	Needle position selector lever cpl.
22	37955	Positioning pin
23	37956	Positioning pin spring

10 - DISC STACK AND BATTERY SELECTOR

REF. N.	PART. N.	PART DESCRIPTION
1	514733-451	BUSHING SCREW
2	422230	DISENGAGING LEVER BUSHING
3	421901	DISENGAGING LEVER
4	421902	DISENGAGING LEVER SPRING
5	421912	CRESCENT RING
6	421898	HINGE STUD
7	421897	DISC FOLLOWER SPRING
8	421896	DISC FOLLOWER
9	511213	RETAINING RING
10	421730-451	DISC FOLLOWER CPL.
11	422498-454	DISC SELECTOR DIAL
12	44730	RETAINING RING
13	422440	DISC POSITIONING SCREW (2)
14	422260	DISC MOUNTING PLATE
15	447546	DISC DRIVING GEAR
16	447548	DISC DRIVING GEAR SHAFT
17	447549	DISC DRIVING GEAR CPL.
18	447531-451	DISC STACK RETAINER IN M/C (WHITE)
18	447531-452	DISC STACK RETAINER IN ATTACHMENT (BLACK)
19	447533-000	DISC STACK "8" ASSEMBLY IN M/C

7-19-59

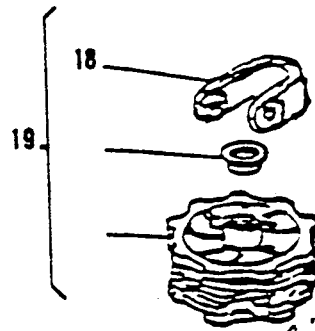
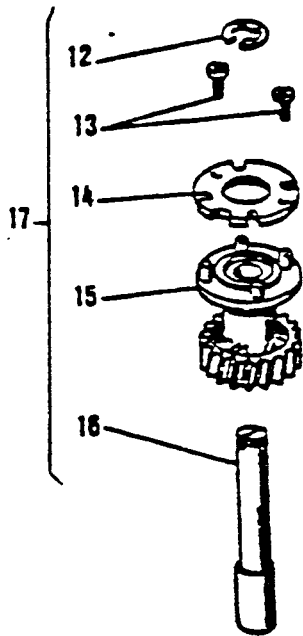
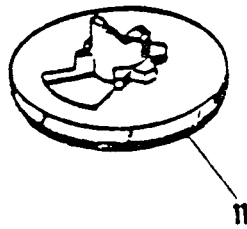
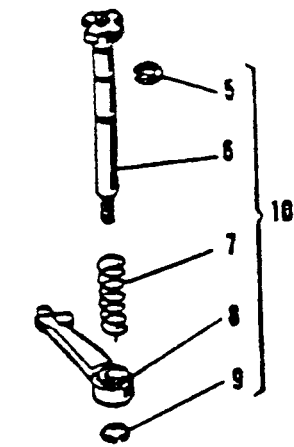
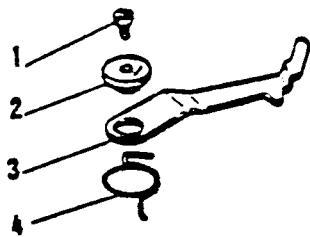

8734

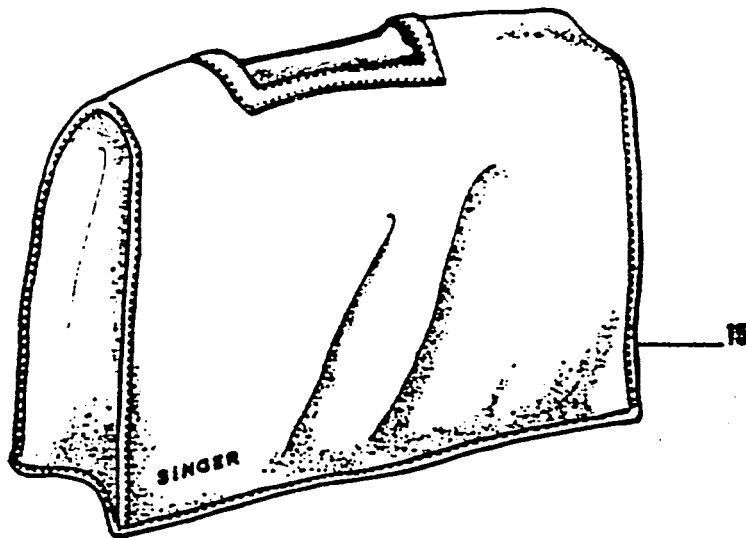
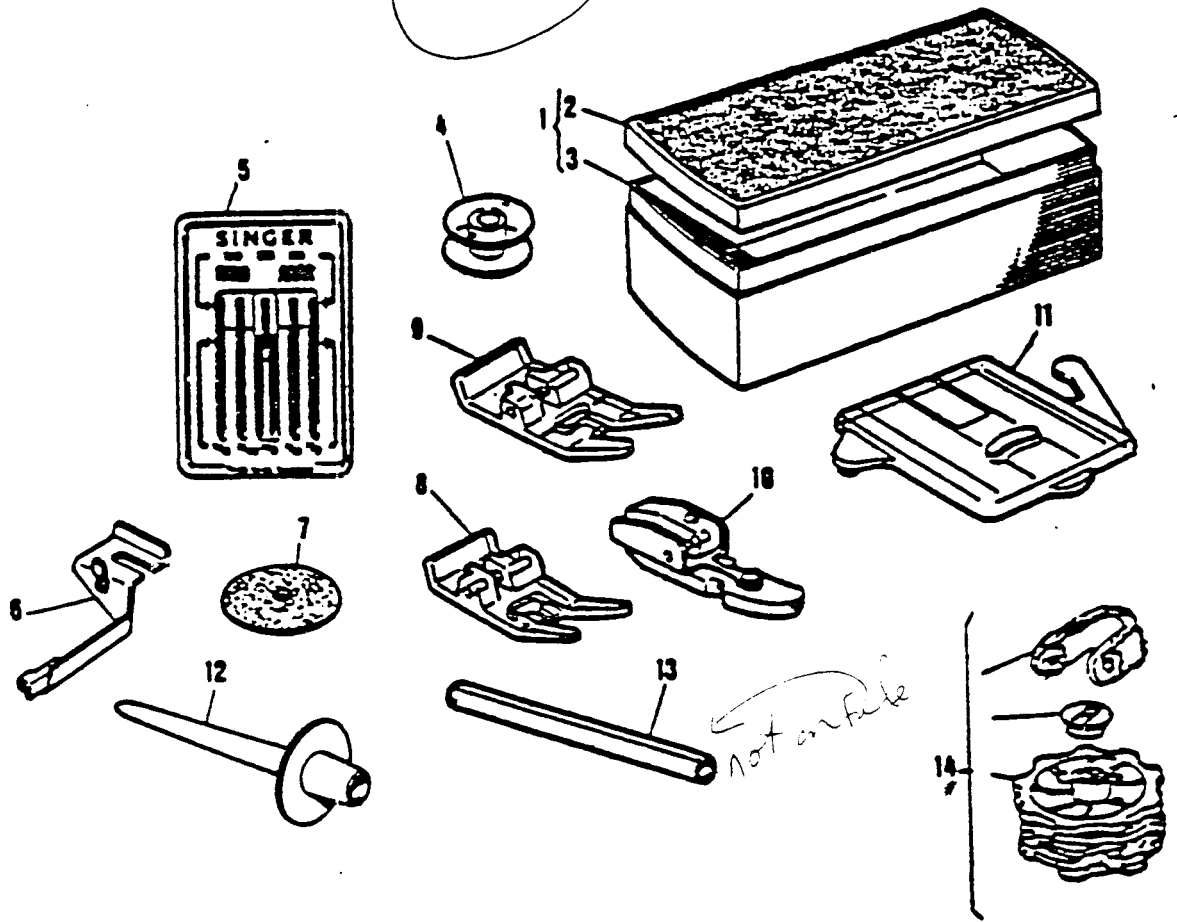

11 - ATTACHMENTS

REF. N.	PART. N.	PART DESCRIPTION
1	421742-451	ATTACHMENT BOX
2	421743	ATTACHMENT BOX COVER
3	421744	ATTACHMENT BOX CASE
4	172336	BOBBIN TRANSPARENT PLASTIC (2)
5	381275	NEEDLE PACK (PLASTIC) CONTAINING : Cat. 2020 : size 14 and 16 Cat. 2025 : size 14 (twin needle) Cat. 2045 : size 11 and 16
6	381213	✓ BLIND STITCH GUIDE ✓
7	8879-454 i	SPOOL PIN FELT
8	171498	✓ SNAP-ON SPECIAL PURPOSE FOOT
9	161927	✓ SNAP-ON BUTTONHOLE FOOT
10	507836	✓ SNAP-ON ZIPPER FOOT
11	381459	✓ SNAP-IN FEED COVER PLATE
12	422250-451	✓ SPOOL PIN ADAPTOR (For twin needle sewing)
13	381800	SPOOL PIN ADAPTOR
14	447534-000	DISC STACK "A8" ASSEMBLY
15	422249-452	SOFT COVER

23
 ↘ 447533-000 2nd DISK STACK
 "Pattern Module"

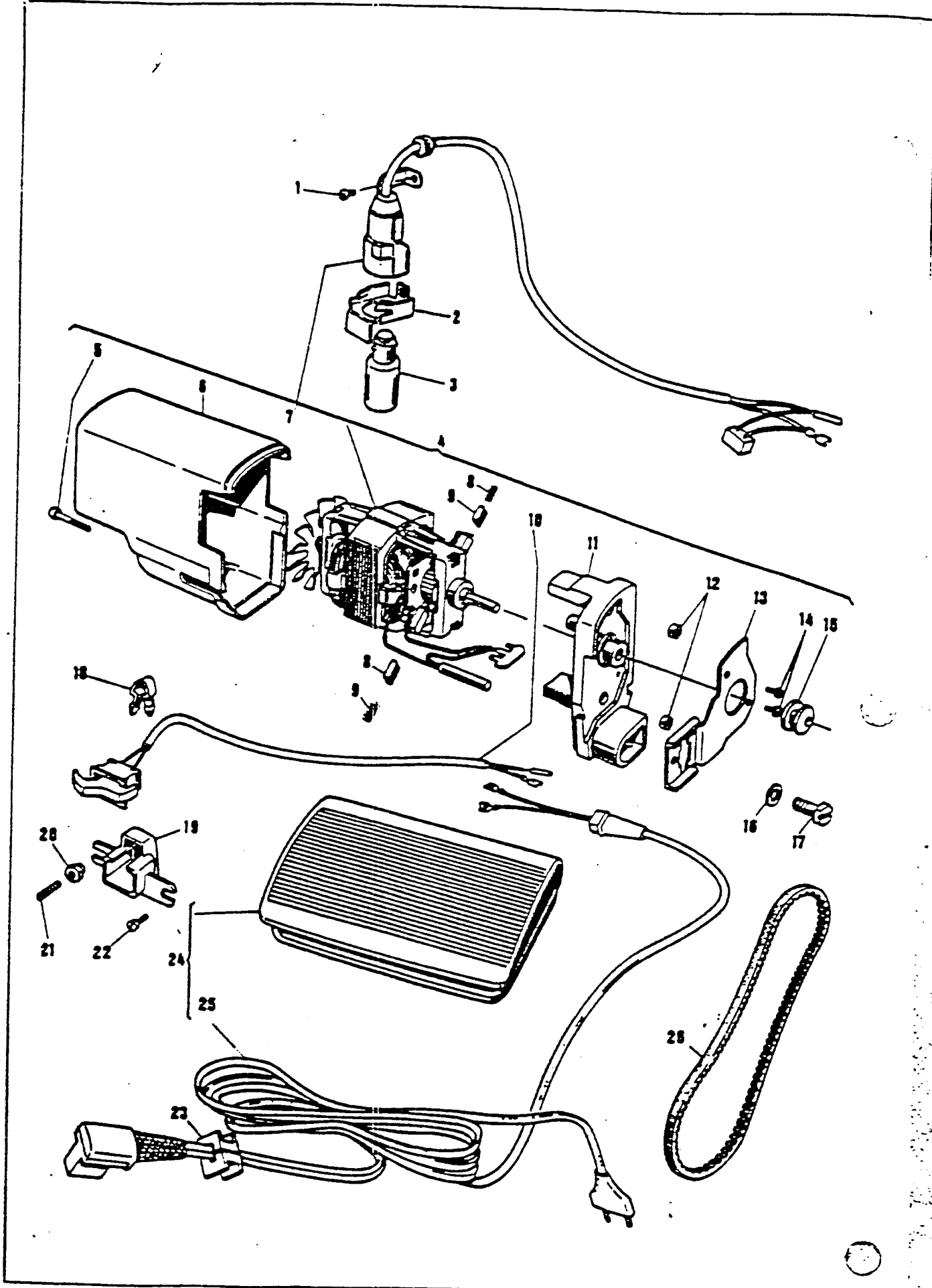

12 - ELECTRICS

8734

01

8834

REF. N.	PART. N.	PART DESCRIPTION
1	421712-451	LIGHT SCREW
2	421967	HEAT SINK
3	194120-016	BULB 15W - 120V → 777910-002
4	605079-208	MOTOR CPL.
5	604016-001	SCREW
6	988136-001	DUST COVER
7	605209-011	LIGHT
8	619436-001	BRUSH SPRING (2)
9	619435-004	BRUSH (2)
10	603985-030	SWITCH CPL. 603985-006
11	988140-001	END HOUSING
12	603907-001	NUT
13	604233-001	MOUNTING BRACKET
14	603956-001	TAPPING SCREW (12)
15	988176-001	PULLEY
16	604018-002	WASHER
17	604020-001	SCREW
18	352745	CLIP
19	604102-001	SWITCH ENCLOSURE
20	514732-451	NUT
21	514731-451	SET SCREW
22	352449	SCREW
24	988274-090	FOOT CONTROLLER → 3620917-001
25	604874-023	CORD CPL.
26	604136-009	MOTOR BELT