

SINGER

495

SINGER®

LIST OF PARTS FOR SEWING MACHINES

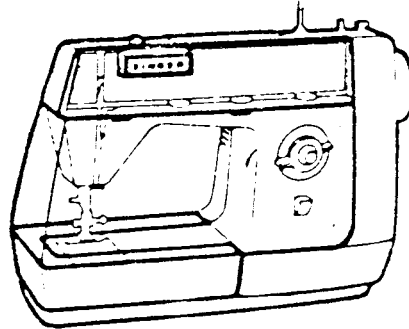

495

• Copyright © 1978 THE SINGER COMPANY
All Rights Reserved Throughout the World

® A Trademark of the SINGER COMPANY

TABLE OF TERRITORIES FOR ELECTRICAL PARTS LISTED ON PAGES 18 & 21

- A - (105/115 V. - 220/240 V.)

Aden
 Algeria
 Angola
 Bahrain
 Bangladesh
 Benin (Dahomey)
 Burma
 Burundi
 Cambodia
 Cameroons
 Cent. Africa Empire
 Chad
 Congo (Brazzaville)
 Egyptian Arab
 Republic
 Ethiopia
 Fiji Islands
 Gabon
 Gambia
 Ghana
 Guam
 Guinea
 Guyana
 High Volta
 Hong Kong
 India
 Indonesia
 Iran
 Iraq
 Ivory Coast
 Jordan
 Kenya
 Kuwait
 Laos
 La Reunion
 Lebanon
 Liberia
 Libya
 Malagasy Rep.
 Malawi
 Malaysia
 Mali
 Mauritania
 Mauritius
 Morocco
 Mozambique
 Niger Repub.
 Nigeria
 North Yemen
 Pakistan
 Rhodesia
 Saudi Arabia
 Senegal
 Sierra Leone
 Singapore
 South Korea
 South Yemen
 Sri Lanka
 Sudan
 Syria
 Taiwan

Tangiers
 Tanzania
 Thailand
 Togo
 Tunisia
 Uganda
 Upper Volta
 Vietnam
 Zaire (Kinshasa)
 Zambia

- B - (220V.)

South Africa

- C - (220 or 240V.)

New Zealand

- D - (240V.)

Great Britain
 (England, Scotland,
 Wales).
 Malta

- E - (220V.)

Netherlands

- F - (220V.)

Austria
 Belgium
 Denmark
 Finland
 Greece
 Italy
 Switzerland
 W. Germany (+ 120V.)

- G - (120V.)

Canada

United States

- H - (120V. + 220V.)

Argentina
 Bahamas
 Barbados
 Bermuda
 Bolivia
 Brazil
 British Honduras
 Canal Zone
 Chile
 Colombia
 Costa Rica
 Ecuador
 El Salvador
 French West Indies
 Guatemala

Honduras Republic
 Jamaica
 Mexico
 Neth. Antilles
 Nicaragua
 Panama
 Paraguay
 Peru
 Philippines
 Puerto Rico
 Surinam
 Trinidad & Tobago
 Venezuela
 Virgin Islands
 West Indies
 (Antigua, Dominica,
 Grenada, Montserrat,
 St. Christopher, Nevis,
 Anguilla, St. Lucia,
 St. Vincent, St. Kitts).

- J - (127/220V.)

Belgium Bi-Volt.
 W. Germany Bi-Volt.

- K - (240V.)

Australia

- L - (220V.)

Norway

- M - (105V.)

Japan

- N - (127/220V.)

France Bi-Volt.
 Non mandatory
 countries Bi-Volt.

- O -

- P - (220V.)

Albania
 France
 Gibraltar
 Iceland
 Israel
 Jugoslavia
 Luxembourg
 Monaco
 Portugal
 Spain
 Turkey

- Q - (240V.)

Cyprus

- R - (220V.)

Sweden

- S - (220V.)

Eire

CONTENTS

MECHANISM GROUP NO.		PAGE
I -	Rear cover and base	5
2 -	Arm shaft pressure bar and tension	7
3 -	Stitch width, needle and pattern position	9
4 -	Needle and hook drive mechanism	11
5 -	Feed control mechanism	13
6 -	Feed drive mechanism	15
7 -	Front cover and control panel	17
20 -	Electrics: Motor-Light	19
21 -	Electrics: Controller	21
9 -	Machine cover cloth plate and attachments	23

MECHANISM 01 REF PART NU.	DESCRIPTION	SOURCE
		495
		B
01 179854	M/C HANDLE BRACKET PLATE	54 *
02 354261-451	M/C HANDLE BRACKET SCREW	54 *
03 139988-451	HANDLE MOUNTING BRACKET SCREW	54 *
04 179856-453	ARM COVER (BACK) CPL.	54 *
05 179813	BOBBIN WINDER TENSION	54 *
06 179812	BOBBIN WINDER TENSION STUD	54 *
07 045847	BOBBIN WINDER TENSION SPRING	56 *
08 045915	BOBBIN WINDER TENSION DISC	54 *
09 319606	BOBBIN WINDER TENSION STUD COLLAR	54 *
10 319663	BOBBIN WINDER TENSION STUD RET. RING	54 *
11 179811	BOBBIN WINDER TENSION STUD BUSHING	54 *
12 319605	B.W. TENSION BUSHING THREAD GUIDE	54 *
13 319673-001	MACHINE HANDLE	54 *
14 179820	MACHINE HANDLE HINGE PIN	54 *
15 179870	MACHINE HANDLE PIN RET. CLAMP	54 *
16 044998-451	ARM COVER BACK SPOOL PIN	54 *
17 139982-451	BOBBIN WINDER STOP SCREW	54 *
18 319601-451	BOBBIN WINDER STOP	54 *
19 319608	BOBBIN WINDER	54 *
20 354223-451	BOBBIN WINDER LEVER HINGE SCREW	54 *
21 319865	BOBBIN WINDER ENGAGING SPRING	54 *
22 319607	BOBBIN WINDER COMPLETE FRAME	56 *
23 319600	BOBBIN WINDER MOUNTING BRACKET	54 *
24 354309-451	BOBBIN WINDER BRACKET SCREW	54 *
25 054580-451	BOBBIN WINDER STOP SCREW NUT	54 *
26 044784	BOBBIN WINDER STOP SCREW NUT RET RING	54 *
27 045000	ARM COVER (BACK) SPOOL PIN RET. CLIP	54 *
28 179857-452	ARM COVER (BACK)	54 *
29 354051-452	SCREW	54 *
30 354051-451	SCREW	54 *
31 139978-451	ARM COVER SCREW	54 *
32 319654	ARM COVER (BACK) BRACKET	54 *
33 141848-819	SCREW	56 *
34 044997	ARM COVER (BACK) BRACKET	54 *
35 141844-819	BRACKET SCREW	56 *
36 319533-453	FACE PLATE COMPLETE	54 *
37 421047	M/C BASE WASHER	54 *
38 514706-451	MACHINE BASE SCREW	54 *
39 514691-451	MACHINE BASE SCREW	54 *
40 421044-451	MACHINE BASE COMPLETE	54 *
41 421045-451	BASE	54 *
42 045780-452	BED COVER PLATE CUSHION	54 *
43 514710-451	MACHINE BASE CUSHION SCREW	54 *

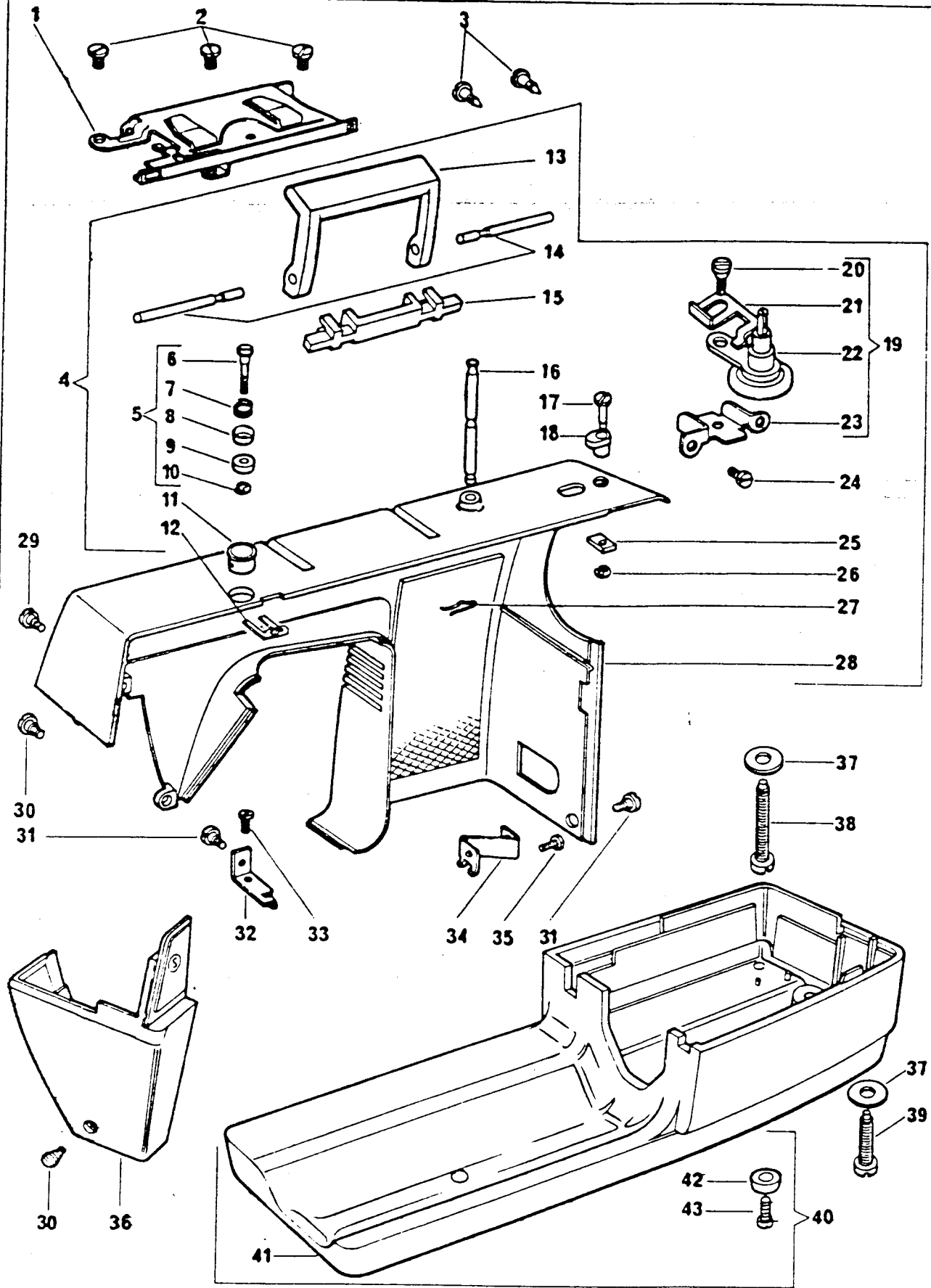

MECHANISM 02 REF PART NO.	DESCRIPTION	SOURCE	495
01 037930	NEEDLE BAR CONNECTING STUD	56	*
02 352746	THREAD TAKE-UP CRANK	56	*
03 352754	THREAD TAKE-UP CRANK WASHER	56	*
04 352753	NEEDLE BAR CONNECTING LINK	56	*
05 141803-830	SET SCREW	56	*
06 044472	THREAD TAKE-UP LEVER LINK STUD RET. RING	56	*
07 446798	THREAD TAKE-UP LEVER LINK HINGE STUD	56	*
08 421310	THREAD TAKE-UP LEVER COMPLETE	56	*
09 141809-451	THREAD TAKE-UP CAP SCREW	56	*
10 037932	NEEDLE BAR CONNECTING STUD HINGE PIN	56	*
11 037931	NEEDLE BAR CONNECTING STUD HINGE PIN	56	*
12 141916-833	ARM SHAFT HORIZ. RETAIN. COLLAR SET SCREW	56	*
13 141844-819	BRACKET SCREW	56	*
14 141830-803	SCREW	56	*
15 319593	PRESSER BAR PRESSURE REGULATING BRACKET	54	*
16 179838	PRESSER BAR BRACKET SLIDE	54	*
17 319801	PRESSER BAR SPRING	54	*
18 446740	PRESSER BAR (HOLLOW)	56	*
19 179846	TENSION RELEASING PIN	54	*
20 037958	PRESSER BAR BUSHING	56	*
21 179862	PRESSER BAR GUIDE BRACKET	56	*
22 155964-892	PRESSER FOOT SHANK	56	*
23 354135-451	PRESSER FOOT THUMB SCREW	56	*
24 155962	PRESSER FOOT PLATE	56	*
25 421063	ARM SHAFT HORIZONTAL	56	*
26 319764	ARM SHAFT HORIZONTAL WASHER	56	*
27 179861	ARM SHAFT HORIZONTAL RETAINING COLLAR	54	*
28 421056	ARM SHAFT BELT DRIVE PULLEY	54	*
29 179865-453	HAND WHEEL COMPLETE	54	*
30 179864-451	HAND WHEEL (PLASTIC)	54	*
31 319563	HAND WHEEL RETAINING RING	54	*
32 179866-453	HAND WHEEL DISENGAGING CLUTCH BUSHING	54	*
33 319557	HAND WHEEL DISENGAGING CLUTCH BUSHING	34	*
34 319566	HAND WHEEL DISENGAGING BUSHING PLATE	54	*
35 319567	HAND WHEEL BUSHING PLATE RETAINER	54	*
36 310806	HAND WHEEL CLUTCH ACTUATING SPRING	54	*
37 179868-453	HAND WHEEL DISENG. CLUTCH ENGAGING PLATE	54	*
38 319561	RETAINING RING	34	*
39 319560	HAND WHEEL CLUTCH ENGAG. PLATE HINGE PIN	54	*
40 139983-451	HAND WHEEL DISENG. CLUTCH BUSHING SCREW	54	*
41 141848-819	SCREW	56	*
42 179845-451	TENSION MOUNTING BRACKET	54	*
43 514541-451	TENSION LEVER BRACKET SCREW	58	*
44 179844	TENSION RELEASING LEVER	54	*
45 354066-451	TENSION MOUNTING BRACKET SCREW	54	*
46 506426-453	TENSION MOUNTING BRACKET AND TENSION	58	*
47 506379	TENSION REGULATING SLIDE PLATE CLIP	58	*

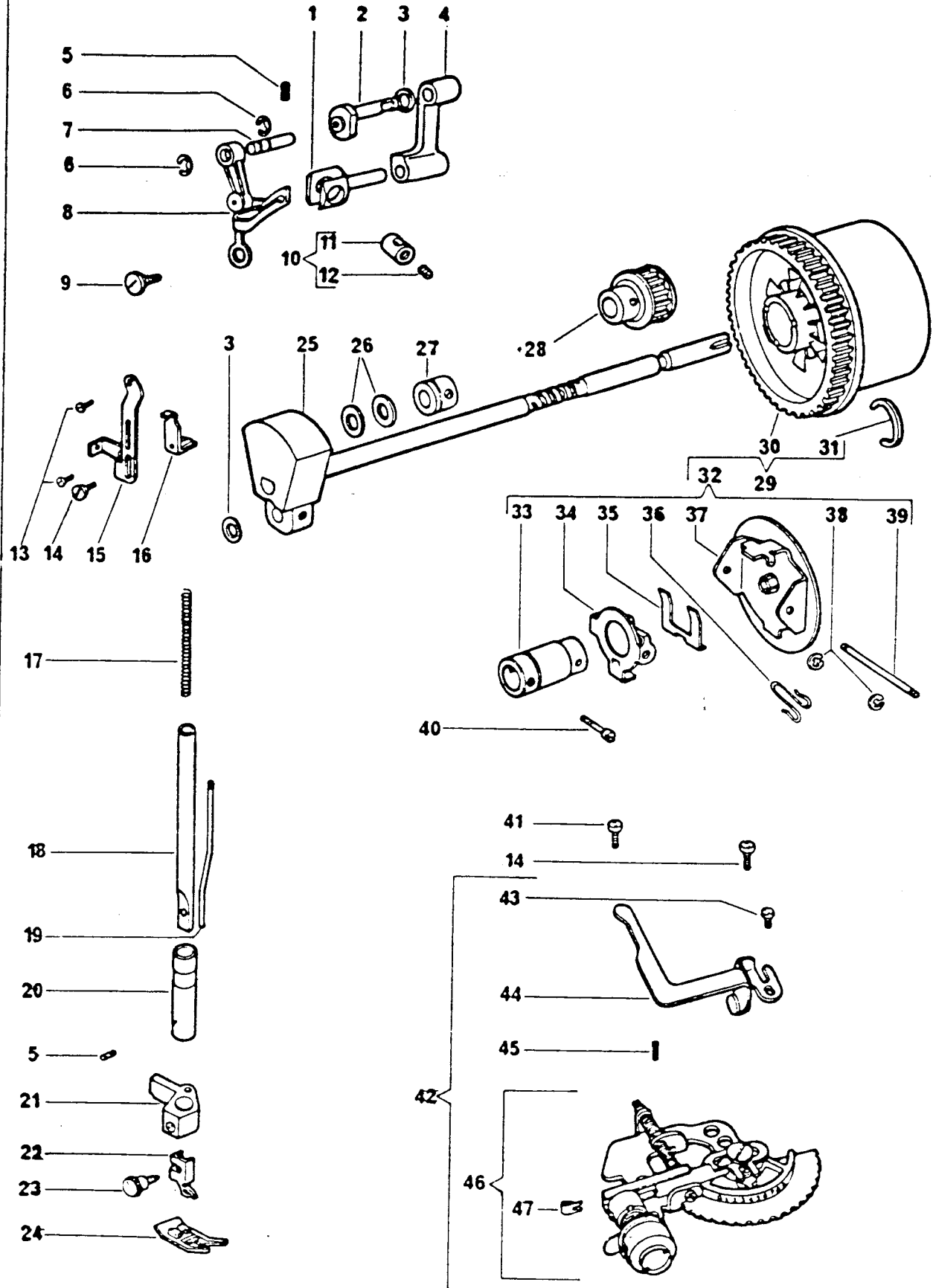

MECHANISM 03			495
REF PART NO.	DESCRIPTION	SOURCE	B
01 037933-803	NEEDLE BAR DRIVING ARM	56 *	
02 037942	NEEDLE BAR ARM TENSION SPRING	56 *	
03 141787-819	BIGHT AMPLITUDE CONTROL LEVER STOP SCREW	56 *	
04 037248	BIGHT AMPLITUDE CONTROL LINK STOP	56 *	
05 319522	BIGHT AMPLITUDE LEVER SCREW	54 *	
06 446737	BELT TENSION FRICTION WASHER	56 *	
07 514707-451	BIGHT AMPLITUDE CONTROL LEVER NUT	58 *	
08 141913-819	SCREW	56 *	
09 421065-451	BIGHT AMPLITUDE CONTROL LEVER	54 *	
10 421067	BIGHT AMPLITUDE CONTROL LEVER LINK	56 *	
11 421070	BIGHT AMPLITUDE CONTROL LEVER CONNECTION	58 *	
12 421195	BIGHT AMPLITUDE CONTROL LEVER RET. RING	58 *	
13 421194-451	BIGHT AMPLITUDE CONTROL LEVER ADJ. STUD	58 *	
14 354083-451	NEEDLE BAR DRIVING ARM STUD SET SCREW	54 *	
15 179792	NEEDLE BAR DRIVING ARM HINGE STUD	54 *	
16 319800	NEEDLE BAR DRIVING ARM SLIDE BRACKET CPL	56 *	
17 053641-819	NUT	56 *	
18 044471	SCREW STUD (ECCENTRIC)	56 *	
19 319789	NEEDLE BAR DRIVING ARM SLIDE BRACKET	54 *	
20 179798	DISC FOLLOWER DISENGAGING LEVER SPRING	54 *	
21 354073-451	DISC SELECTOR LEVER HINGE SCREW	54 *	
22 319531-452	DISC SELECTOR LEVER	54 *	
23 319666	DISC FOLLOWER STUD SCREW	54 *	
24 179796	DISC FOLLOWER DISENGAGING LEVER	54 *	
25 179795	DISC FOLLOWER DISENGAGING LEVER	54 *	
26 044419	DISC FOLLOWER POSITIONING SPRING	56 *	
27 037262-830	DISC FOLLOWER	56 *	
28 179800	DISC SELECTOR CAM SLIDE	54 *	
29 037276-819	DISC SELECTOR CAM SLIDE WASHER	56 *	
30 037269	DISC FOLLOWER STUD	56 *	
31 044371	DISC FOLLOWER STUD RETAINING RING	56 *	
32 037258	DISC FOLLOWER STUD	56 *	
33 514693-451	NEEDLE POSITION SELECTOR LEVER STUD NUT	58 *	
34 319590-452	NEEDLE POSITION SELECTOR LEVER	54 *	
35 037953-805	NEEDLE POSITION SELECTOR LEVER BRACKET	56 *	
36 421078	NEEDLE POSITION SELECTOR LEVER STUD	58 *	
37 507343	NEEDLE POSITION LEVER RET. RING	54 *	
38 421079	NEEDLE POSITION LEVER CONNECTION	58 *	
39 141848-819	SCREW	56 *	
40 421163	DISC FOLLOWER DIS. LEVER SPRING BRACKET	54 *	
41 179817	DISC DRIVING GEAR COMPLETE	54 *	
42 354259-451	DISC POSITIONING SCREW	54 *	
43 179303	DISC STACK (PLASTIC)	54 *	
44 044730	DISC DRIVING GEAR RETAINING RING	56 *	
45 037257	DISC DRIVING GEAR	56 *	
46 037261	DISC DRIVING GEAR SHAFT	56 *	
47 141803-830	SET SCREW	56 *	
48 037955-803	NEEDLE POSITION POSITIONING PIN	56 *	
49 037956	NEEDLE POSITION POSITIONING PIN SPRING	56 *	
50 506318-453	TENSION COMPLETE	58 *	
51 514605-453	TENSION CAP AND SLACK THREAD REGULATOR	58 *	

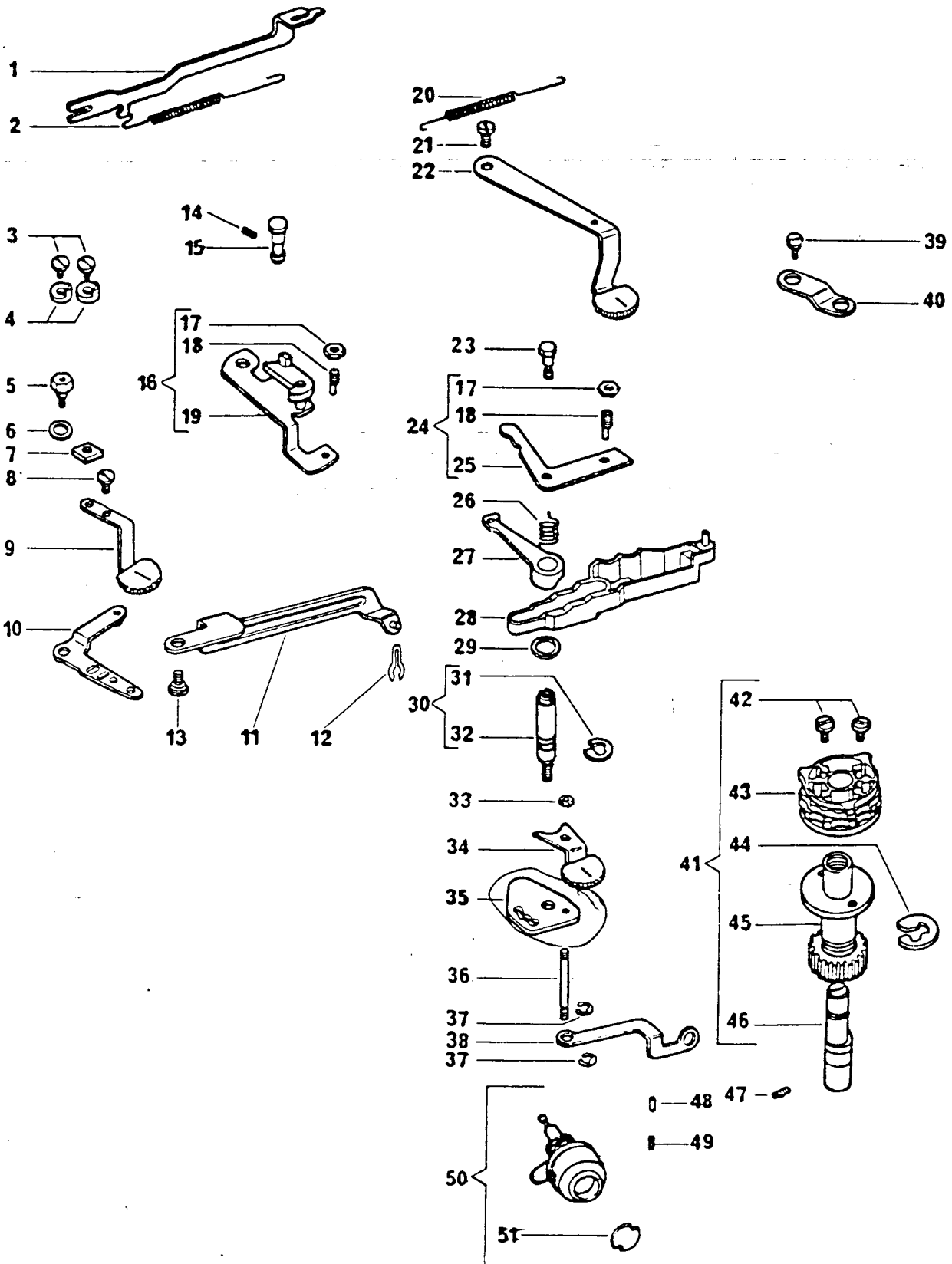

MECHANISM 04			495
REF PART NO.	DESCRIPTION	SOURCE	B
01 141913-833	SCREW	56	*
02 446952	NEEDLE BAR VIBRATING BRACKET COMPLETE	56	*
03 037935	NEEDLE BAR DRIVING ARM HINGE PIN	56	*
04 354621	NEEDLE BAR DRIVING ARM HINGE SCREW	56	*
05 037934	NEEDLE BAR DRIVING ARM HINGE BRACKET	56	*
06 037944	NEEDLE BAR VIBRATING BRACKET	56	*
07 141940-833	NEEDLE BAR BRACKET HINGE PIN SET SCREW	56	*
08 141803-830	SET SCREW	56	*
09 037928	NEEDLE BAR BALL BUSHING ADJUSTING COLLAR	56	*
10 507379	NEEDLE BAR BALL SOCKET	56	*
11 037927-001	NEEDLE BAR BALL BUSHING (UPPER)	56	*
12 445124	NEEDLE BAR VIBRATING BRACKET HINGE PIN	56	*
13 044673-001	NEEDLE BAR VIBRATING BRACKET PIN COLLAR	56	*
14 421172	NEEDLE BAR	56	*
15 044450-850	NEEDLE BAR BALL BUSHING (LOWER) SOCKET	56	*
16 037927-001	NEEDLE BAR BALL BUSHING (UPPER)	56	*
17 044473-819	NEEDLE BAR BALL BUSHING ADJ. SCREW	56	*
18 037943	NEEDLE BAR GIB	56	*
19 141803-892	NEEDLE CLAMP BODY AND NEEDLE STOP SCREW	56	*
20 2J20	NEEDLE (15X1) SIZE NO 11-14-16		*
21 319729	NEEDLE CLAMP COMPLETE	56	*
22 511171-829	NEEDLE THUMB SCREW	56	*
23 319723	NEEDLE CLAMP BODY	56	*
24 172336	ROTATING HOOK BOBBIN	56	*
25 421325	ROTATING HOOK BOBBIN CASE (STARLET)	54	*
25 421326	ROTATING HOOK BOBBIN CASE CPL (GENIE 2)	54	*
26 352883	ROTATING HOOK	56	*
27 506164	DAMPING WASHER	58	*
28 421199	ROTATING HOOK FLANGED BUSHING (ECC.)	34	*
29 354133-451	ROTATING HOOK BUSHING ADJ. SCREW	34	*
30 514689-451	ROTATING HOOK BUSHING (ECC) SCREW	54	*
31 116084	ROTATING HOOK COLLAR	34	*
32 103351	ROTATING HOOK BEVEL GEAR	34	*
33 310903	ROT. HOOK BOBBIN CASE RET. PLATE	34	*
34 319735	ROT. HOOK BOBBIN CASE RET. SPRING	34	*
35 319737-451	ROT. HOOK BOBBIN CASE RET. WASHER	34	*
36 319736	ROT. HOOK BOBBIN CASE RET. CLIP	34	*
37 312391	THROAT PLATE	34	*
38 310791	THROAT PLATE CLAMP	34	*
39 141947-819	SCREW	56	*
40 179822	PRESSER BAR LEVER	54	*
41 153930	THROAT PLATE CLAMP SPRING	34	*
42 179658	THROAT PLATE CLAMP SPRING RET. RING	34	*
43 116080	BED SLIDE COMPLETE	34	*
44 381903	RETAINING PLATE	56	*
45 354229-451	ROT. HOOK BOBBIN CASE PLATE SCREW	56	*
46 354134-451	BED SLIDE SPRING SCREW	34	*
47 103344	BED SLIDE SPRING	34	*
48 044873	ROTATING HOOK BOBBIN CASE POSITION PLATE	56	*
49 354227-451	ROT. HOOK BOBBIN CASE PLATE SCREW	56	*
50 421035-001	ROTATING HOOK DRIVE SHAFT TIMING BELT	54	*
51 507905	ARM SHAFT BELT PULLEY BRACKET COMPLETE	58	*
52 514703-451	ARM SHAFT BELT IDLER PULLEY BRACKET S	54	*

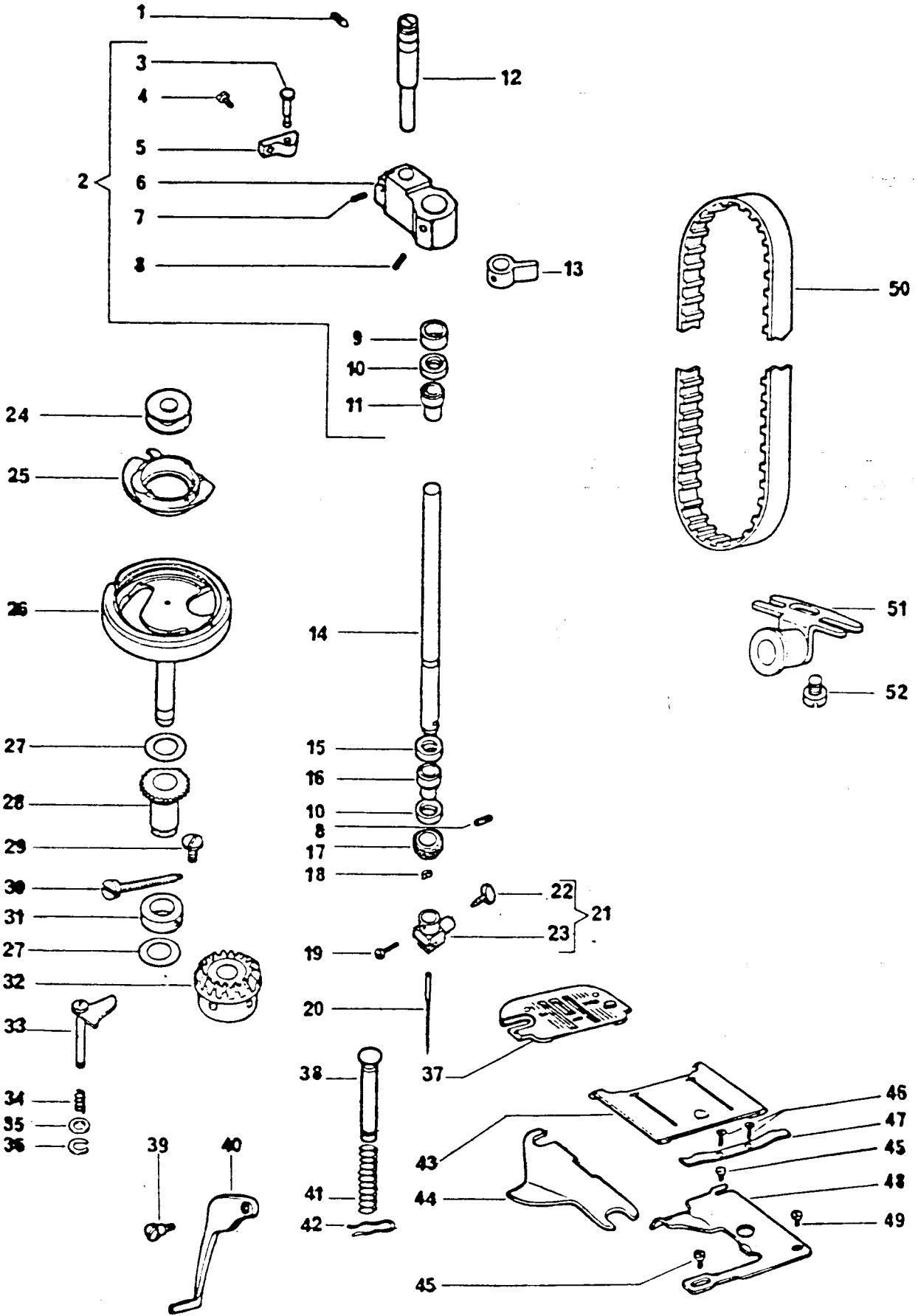

MECHANISM 05			495
REF PART NO.		DESCRIPTION	SOURCE
			B
01	421114	M/C CAM CONTROLLED FEED BALANCING CAM	58 *
02	354050-451	LIGHT SHIELD SCREW NO. 10	54 *
03	421119	M/C CONTROLLED FEED CAM FRICTION SPRING	58 *
04	421157	BUTTONHOLE FEED CONTROL MECHANISM CPL	58 *
05	421082	BUTTONHOLE AND FEED CONTROL BRACKET	58 *
06	421174	BUTTONHOLE LEVER WITH CAM STUD	58 *
07	507684	SPRING WASHER	58 *
08	421197	RETAINING RING	58 *
09	421089	BUTTONHOLE MECHANISM PLATE PAWL	58 *
10	421090	BUTTONHOLE MECHANISM PLATE SPRING	58 *
11	507063	RETAINING RING	58 *
12	421106	M/C CONTROLLED FEED RETURN SPRING	58 *
13	507309	RETAINING RING	58 *
14	421160	MACHINE CONTROLLED FEED HINGE COMPLETE	58 *
15	421110	FEED CONTROL HINGE COMPLETE	58 *
16	421324	BUTTONHOLE AND FEED CONTROL CAM RING	58 *
17	421323	BUTTONHOLE AND FEED CONTROL CAM SPRING	58 *
18	421322	BUTTONHOLE AND FEED CONTROL CAM WASHER	58 *
19	421091-001	BUTTONHOLE AND FEED CONTROL CAM	58 *
20	511213	RETAINING RING	34 *
21	421093	BUTTONHOLE NEEDLE POS. CAM LEVER	58 *
22	354041-452	BUTTONHOLE MECHANISM SCREW	54 *
23	421164	BUTTONHOLE MECHANISM PLATE	58 *
24	421099	REVERSE FEED DIAL LEVER SPRING	58 *
25	421097-451	REVERSE FEED DIAL LEVER	58 *
26	421122	FEED CONTROL CONNECTION LINK COMPLETE	58 *
27	514698-451	NUT	58 *
28	514697-451	FEED REGULATOR SHAFT LEVER SCREW	58 *
29	141343-819	SCREW	56 *
30	421117	M/C CAM FEED BALANCING COLLAR	58 *
31	514699-451	BUTTONHOLE NEEDLE POS. CAM HINGE SCREW	58 *
32	421177	BUTTONHOLE AND FEED CONTROL DIAL CPL	54 *
33	421120-451	BUTTONHOLE AND FEED CONTROL DIAL	54 *
34	421173	BUTTONHOLE AND FEED CONTROL DIAL SPRING	58 *
35	421121-451	BUTTONHOLE BALANCING CONTROL DIAL	54 *

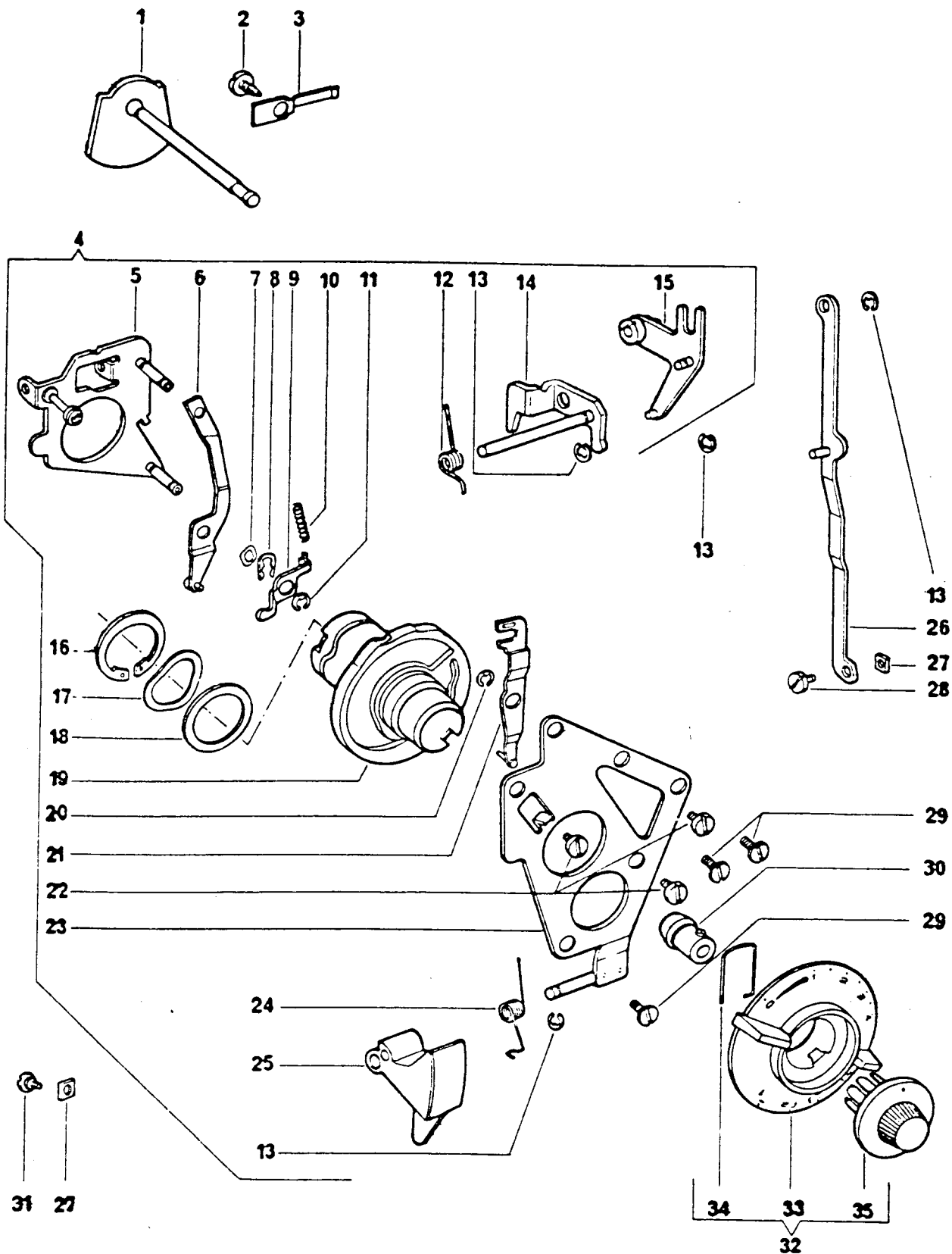

MECHANISM 06 REF PART NO.	DESCRIPTION	SOURCE	495 B
01 507917	FEED BAR GUIDE PIN (ECC.)	58	*
02 514556-451	FEED BAR GUIDE PIN (ECC.) SCREW	58	*
03 421040	FEED BAR COMPLETE	34	*
04 000448-451	FEED BAR CONNECTING -SCREW	34	*
05 421041	FEED BAR COMPLETE	34	*
06 500356	FEED DJG HOLDER COMPENSATING LINK SCREW	34	*
07 312284	FEED DJG HOLDER COMP LINK RETAIN SPRING	34	*
08 174216	FEED DJG HOLDER COMPENSATING LINK	34	*
09 511211	FEED BAR GUIDE HINGE PIN SPRING WASHER	34	*
10 511413	FEED BAR GUIDE HINGE PIN RETAINING RING	34	*
11 421042	FEED BAR GUIDE PIN (ECC.)	34	*
12 500355-451	FEED BAR GUIDE HINGE PIN LOCK SCREW	34	*
13 000624-830	FEED DJG HOLDER STUD SCREW	34	*
14 511210	FEED DJG HOLDER WASHER	34	*
15 511052	FEED DJG HOLDER STUD	34	*
16 511213	RETAINING RING	34	*
17 319561	RETAINING RING	34	*
18 511016	FEED LIFTING FORK CONNECTION	34	*
19 116082	FEED BAR CONNECTION WITH ECCENTRIC CPL	34	*
20 511044	LIFT FORK CONNECTION HINGE STUD	34	*
21 507722	FEED BAR CONNECTION SPRING WASHER	34	*
22 141338-869	SET SCREW	34	*
23-319561	RETAINING RING	34	*
24 103380	FEED LIFTING CAM AND FEED RETAINING RING	34	*
25 511056	FEED LIFTING FORK CONNECTING STUD (ECC)	34	*
26 506468	FEED REGULATOR SLIDE BLOCK COMPLETE	34	*
27 511030	FEED REGULATOR SLIDE BLOCK	34	*
28 500391-803	FEED REGULATOR SET SCREW	34	*
29 421039	FEED REGULATOR SHAFT	58	*
30 502744	FEED REGULATOR SHAFT RETAINING RING	58	*
31 502310	FEED BAR GUIDE PIN CENTER COMPLETE	58	*
32 421140	FEED REGULATOR SHAFT CONTROLLING LEVER	58	*
33 421143	FEED REGULATOR SHAFT LEVER SPRING	58	*
34 103775	FEED LIFTING FORK COMPLETE	34	*
35 511057	FEED LIFTING FORK HINGE STUD	34	*
36 050311-830	FEED LIFTING FORK CONNECTING SET SCREW	34	*
37 114234-451	FEED LIFTING FORK HINGE STUD SET SCREW	34	*
38 103377	FEED DJG	34	*
39 379505-451	FEED DJG SCREW	34	*
40 153356	FEED DRIVE SHAFT	34	*
41 153487	FEED DRIVE SHAFT GEAR	34	*
42 421504	WASHER	58	*
43 103363	ROTATING HOOK DRIVE SHAFT BEVEL GEAR	34	*
44 421036	ROTATING HOOK DRIVE SHAFT	34	*
45 153490	ROTATING HOOK DRIVE SHAFT GEAR	34	*
46 421314	DAMPING WASHER	58	*
47 421037	ROTATING HOOK DRIVE SHAFT BELT PULLEY	58	*

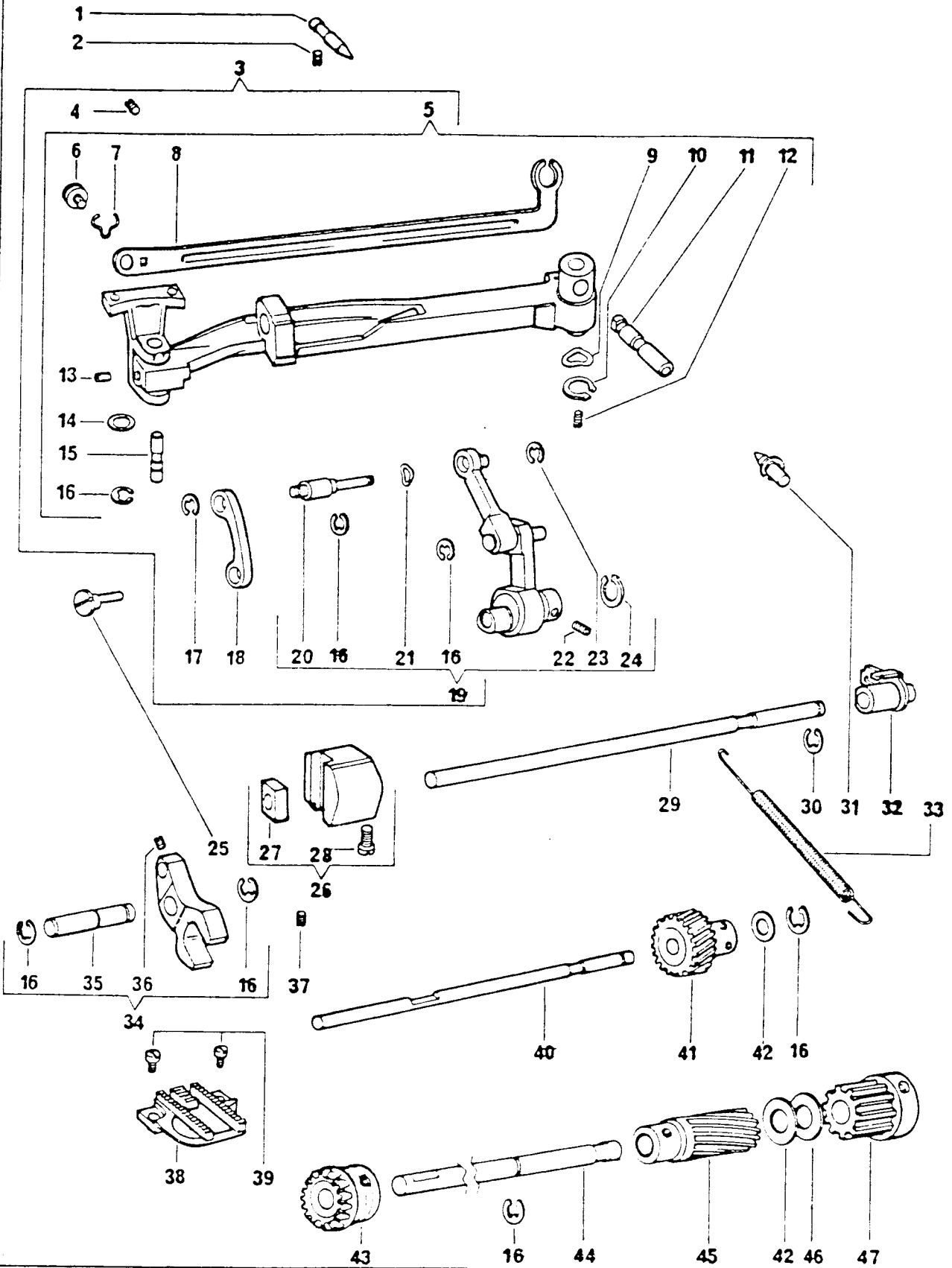

MECHANISM 07 REF PART NO.	DESCRIPTION	SOURCE	495
01 421156	CONTROL PANEL (STARLET)	54 *	B
01 421327	CONTROL PANEL (GENIE 2)	54 *	
02 421147-451	ARM COVER FRONT COMPLETE (STARLET)	54 *	
02 421179-451	ARM COVER FRONT COMPLETE (GENIE 2)	54 *	
03 421148-451	ARM COVER FRONT COMPLETE (STARLET)	54 *	
03 421180-451	ARM COVER FRONT COMPLETE (GENIE 2)	54 *	
04 319506	ARM COVER THREAD GUIDE (UPPER)	54 *	
05 354141-451	THREAD GUIDE (UPPER) SCREW	54 *	
06 354051-452	SCREW	54 *	
07 421145-451	SWITCH ENCLOSURE	54 *	
08 139978-452	ARM COVER SCREW	54 *	
09 139979-451	ARM COVER FRONT SCREW	54 *	
10 179818	THREAD GUIDE (AGENCES)	56 *	
11 179874-451	BED COVER (TUBULAR)	54 *	
12 514690-451	BED COVER (TUBULAR) SCREW	54 *	

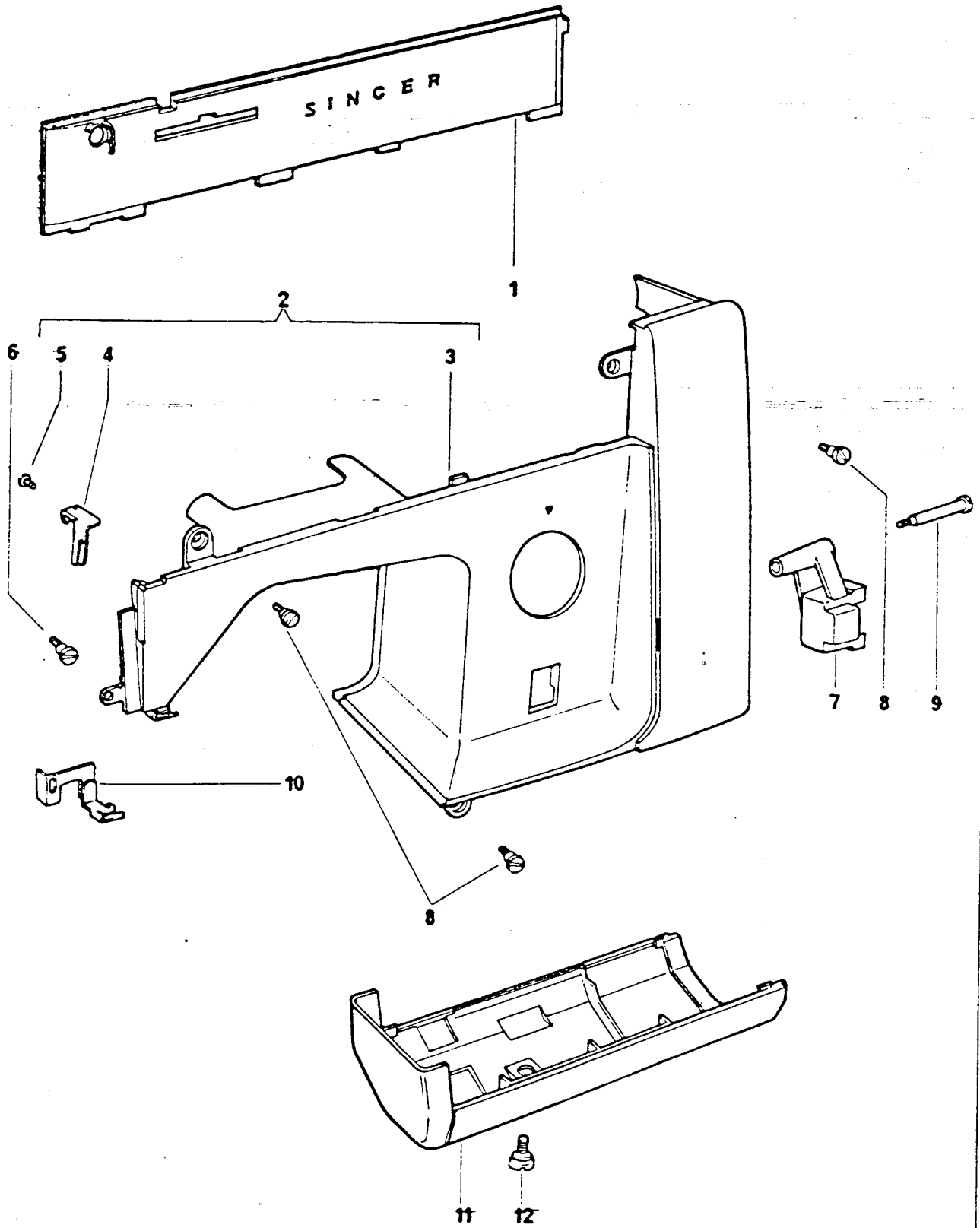

MECHANISM 20 REF PART NO.	DESCRIPTION	SOURCE	495
			B
J1 603976-001	LIGHT BRACKET SPRING SCREW MM	54 *	
J2 603987-001	LIGHT BRACKET SPRING	54 *	
03 619644-001	MOTJR COMPLETE HAB 2 110V PEACH TINT	54 *G.....
03 619644-002	MOTJR COMPLETE HAB 2 120V PEACH TINT	54 *	..A.....H.....
03 619644-003	MOTJR COMPLETE HAB 2 220V PEACH TINT	54 *	.A..B.C..F..H..L..P.R...
03 619644-004	MOTJR COMPLETE HAB 2 240V PEACH TINT	54 *	A.....D.....K.....
J3 619644-005	MOTJR COMPLETE HAB 2 240V PEACH TINT	54 *J.....
03 619644-006	MOTJR COMPLETE HAB 2 127/220V PEACH TINT	54 *NN.....
03 619644-007	MOTJR COMPLETE HAB 2 127/220V PEACH TINT	54 *E.....
03 619644-008	MOTJR COMPLETE HAB 2 220V PEACH TINT	54 *G.....
04 605209-001	LIGHT COMPLETE L 10	54 *	AAA.BCCD.FF.HH..L.NNP.R...
04 605209-002	LIGHT COMPLETE L 10	54 *K.....
04 605209-003	LIGHT COMPLETE L 10	54 *J.....
04 605209-004	LIGHT COMPLETE L 10	54 *E.....
04 605209-005	LIGHT COMPLETE L 10	54 *G.....
05 603977-001	SWITCH COMPLETE PEACH TINT	54 *K.....
J5 603977-003	SWITCH COMPLETE PEACH TINT	54 *	AAA.BCCD.F..HHJ.L.N.P.R...
05 603977-004	SWITCH COMPLETE PEACH TINT	54 *E.....
J5 603977-005	SWITCH COMPLETE PEACH TINT	54 *	
06 603956-001	TAPPING SCREW MM	54 *	
J7 604209-002	MOUNTING BRACKET	54 *	
08 604437-001	PULLEY BLACK	54 *	
09 603907-001	NUT MM	54 *	
10 604008-002	COMMUTATOR END HOUSING BLACK	54 *	
11 619436-001	BRUSH SPRING	54 *	
12 619435-004	BRUSH	54 *	
13 604054-013	MOTJR MODULE 110/120V	54 *G.....
13 604054-014	MOTJR MODULE 210/230V	54 *	..A..B.C..F..H..L..P.R...
13 604054-015	MOTJR MODULE 230/250V	54 *	A.....D.....K.....
13 604054-016	MOTJR MODULE 110/120V	54 *	..A.....H.....
13 604054-017	MOTJR MODULE 210/230V	54 *E.....
13 604054-018	MOTJR MODULE 127/220V	54 *J.....
13 604054-019	MOTJR MODULE 127/220V	54 *NN.....
14 604013-001	DUST COVER RETAINING BLOCK	54 *	
15 604216-004	DUST COVER BLACK	54 *J.....NN.....
15 604722-001	DUST COVER BLACK	54 *	AAAABCCDEFFGHH.KLM..PQRS...
16 604016-001	SCREW NO.4	54 *	
17 604020-001	MACHINE MOUNTING SCREW 9/ 32-20 S.S.	54 *	
18 604018-002	MACHINE MOUNTING SCREW WASHER	54 *	
19 603975-001	MOTJR BELT	54 *	
20 352624-452	LIGHT SHIELD	54 *	
21 354050-451	LIGHT SHIELD SCREW NO. 10	54 *	

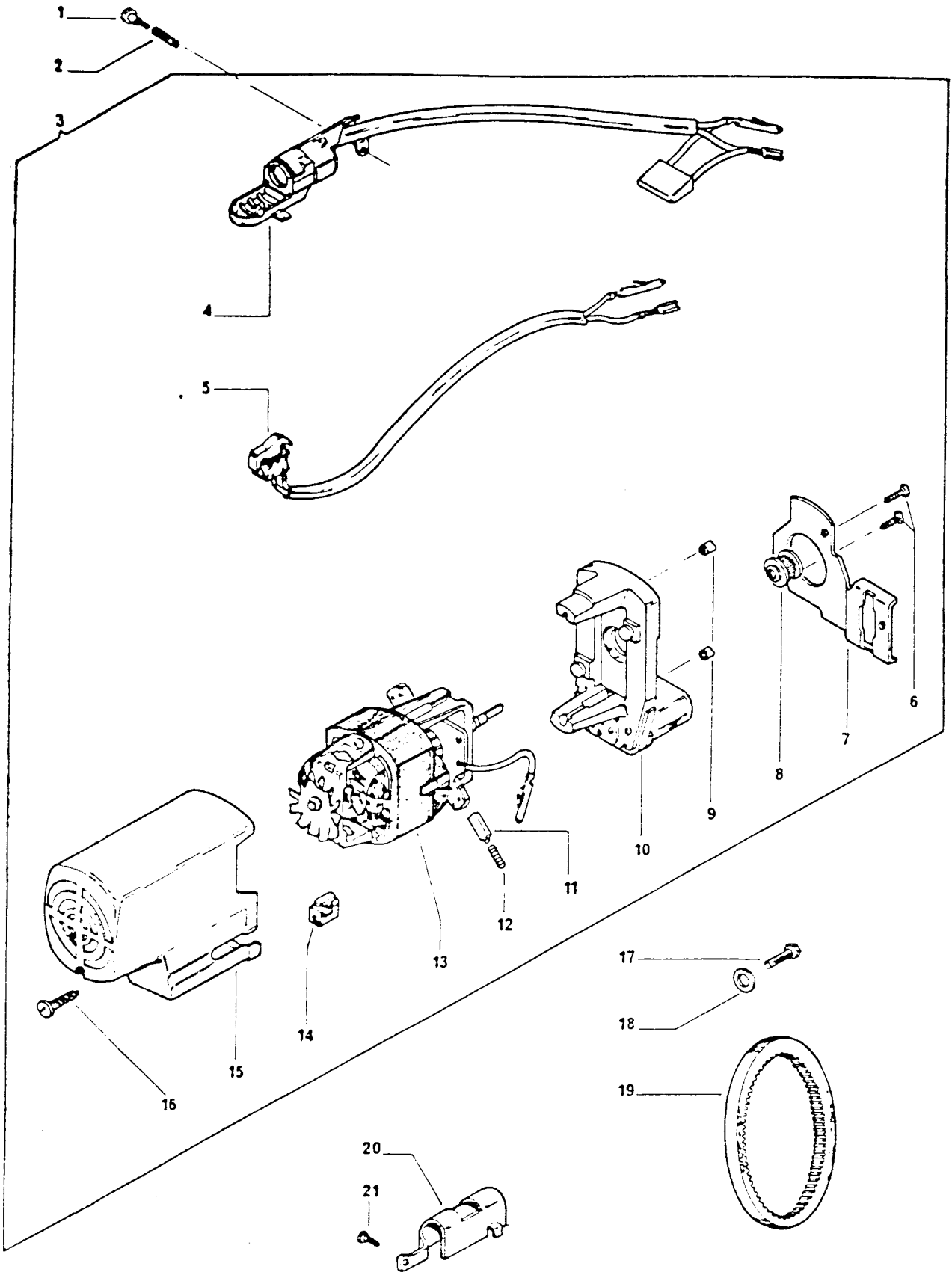

MECHANISM 21			495	
REF PART NO.	DESCRIPTION	SOURCE		
			B	
01 604174-002	CR 303 B CONTROLLER 150/250 V PLUG	54 *	L.....
01 619494-002	CR 303 B CONTROLLER 095/145 V PLUG	54 *	G.....
01 619494-003	CR 303 B CONTROLLER 150/250 V NO PLUG	54 *	B.....
01 619494-004	CR 303 B CONTROLLER 095/145 V PLUG	54 *		..AA.....
01 619494-005	CR 303 B CONTROLLER 150/250 V PLUG	54 *		AA.....N.....
01 619494-006	CR 303 B CONTROLLER 150/250 V PLUG	54 *	K.....
01 619494-007	CR 303 B CONTROLLER 095/145 V PLUG	54 *		...A.....
01 619494-009	CR 303 B CONTROLLER 150/250 V PLUG	54 *	CC.....
01 619494-010	CR 303 B CONTROLLER 095/145 V PLUG	54 *	H.....
01 619494-011	CR 303 B CONTROLLER 150/250 V PLUG	54 *	H.....
01 619494-030	CR 303 B CONTROLLER 150/250 V PLUG	54 *		AA.....
01 619494-079	CR 303 B CONTROLLER 150/250 V PLUG	54 *	EF...J...N.PQ..
01 619494-082	CR 303 B CONTROLLER 150/250 V NO PLUG	54 *	D.....S
01 619494-091	CR 303 B CONTROLLER 150/250 V PLUG	54 *	R.....
02 619142-002	PROTECTOR	54 *	K.M.....
03 618634-003	CONTACT SPACER FASTENING SCREW MM	54 *		
04 701511-816	CONTACT SPACER FASTENING WASHER	54 *		
05 618718-001	PUSH-ON FASTENER	54 *		
06 618609-001	ACTUATING SPRING	54 *		
07 618542-001	PEDAL RETURN SPRING	54 *		
08 618634-004	SCREW MM	54 *		
09 618815-001	SHORTING STRAP	54 *		
10 618612-001	RESISTANCE UNIT CLAMP	54 *		
11 618804-001	RESISTANCE UNIT COMPLETE 150/250V	54 *		AA..BCCDEF..H.JKL..NNPQRS
11 618804-003	RESISTANCE UNIT COMPLETE 095/145V	54 *		..AA.....FG.H...M.....
12 618637-001	CONTROLLER LEAD FASTENING SCREW MM	54 *	K.....
13 618987-001	CONTACT SPACER WASHER (UPPER)	54 *	K.....
14 618983-001	CONTACT SPACER WASHER (LOWER)	54 *	K.....
15 140677-005	STRAIN RELIEF BRACKET SCREW 4-40 NC2.	54 *	KL.....
16 618613-002	STRAIN RELIEF BRACKET	54 *	KL.....
17 618638-001	CONTROLLER LEAD FASTENING SCREW NUT MM	54 *	K.....
18 618634-002	STRAIN RELIEF BRACKET HOLDER SCREW MM	54 *	KL.....
19 603877-001	STRAIN RELIEF BRACKET HOLDER	54 *	KL.....
20 618603-001	CONTACT SPACER TOP	54 *	KL.....
21 604164-901	CONTACT SPRING	54 *		
22 604166-901	CONTACT SPACER BOTTOM	54 *		
23 604165-901	SHORTING SPRING	54 *		
24 619491-002	RUBBER FOOT BLACK	54 *		
25 618313-001	STRAIN RELIEF BRACKET	54 *		AAAAABCCDEFFFGHHJ..MNNPQRS
26 604874-001	LINE AND CONTROLLER CORD COMPLETE	54 *		AAAA.....EFF...J...NNPQ..
26 604874-002	LINE AND CONTROLLER CORD COMPLETE	54 *	L.....
26 604874-003	LINE AND CONTROLLER CORD COMPLETE	54 *	B..D.....S
26 604874-004	LINE AND CONTROLLER CORD COMPLETE	54 *		..A.....
26 604874-005	LINE AND CONTROLLER CORD COMPLETE	54 *	CC.....
26 604874-006	LINE AND CONTROLLER CORD COMPLETE	54 *	K.....
26 604874-007	LINE AND CONTROLLER CORD COMPLETE	54 *	G.....
26 604874-010	LINE AND CONTROLLER CORD COMPLETE	54 *	HH.....
26 604874-012	LINE AND CONTROLLER CORD COMPLETE	54 *	R.....
27 604049-905	CAPACITOR (ANTI-CLICK)	54 *	DEFF...J..L..N..PQRS
28 619454-002	CAPACITOR COMPLETE	54 *		AAAAABCCDEFF..HHJKL..MNNPQRS
29 619179-001	RETAINING CUP	54 *		
30 603758-003	SHOULDER SCREW MM	54 *		
31 619492-002	SNAP-IN PLUG	54 *		
32 604636-001	SECURITY SCREW NO.6	54 *		
33 619493-005	BASE AND PEDALE ASSEMBLED BLACK	54 *		
34 603832-001	HEAT SHIELD	54 *		

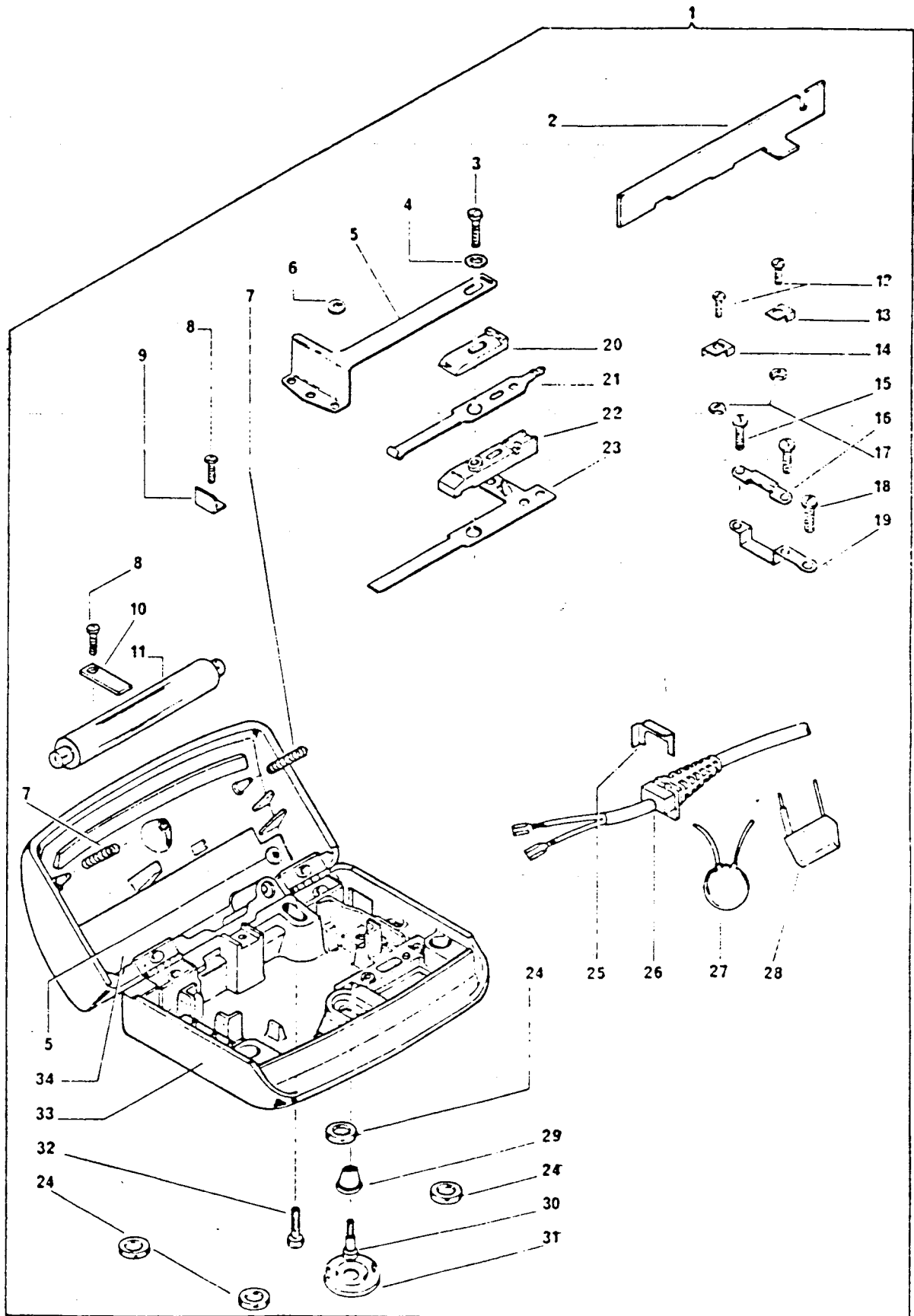

MECHANISM 09 REF PART NO.	DESCRIPTION	SOURCE	495
			B
01 319706-453	MACHINE COVER COMPLETE (STARLET)	54	*
01 421182-451	MACHINE COVER COMPLETE (GENIE2)	54	*
02 319570-451	M/C COVER LID RELEASING BUTTON	54	*
03 319571	MACHINE COVER LID CATCH	54	*
04 179827	M/C COVER LID RELEASING BUTTON SPRING	54	*
05 139985-452	M/C COVER LID BUTTON BRACKET SCREW	54	*
06 319710	M/C COVER LID BUTTON BRACKET	54	*
07 319705-453	MACHINE COVER LID CPL (STARLET)	54	*
07 421183-451	MACHINE COVER LID CPL (GENIE 2)	54	*
08 139986-451	MACHINE COVER LID HINGE SCREW	54	*
09 319689	MACHINE COVER LID HINGE COMPLETE	54	*
10 319575	MACHINE COVER LID HINGE SPRING	54	*
11 179789-451	MACHINE COVER	54	*
12 421154-001	INSTRUCTION BOOK (GENIE 2) INT. GROUP	54	*
12 421155-001	INSTRUCTION BOOK (STARLET) ENGLISH	54	*
12 421155-002	INSTRUCTION BOOK (STARLET) FRENCH	54	*
12 421155-003	INSTRUCTION BOOK (STARLET) GERMAN	54	*
12 421155-004	INSTRUCTION BOOK (STARLET) ITALIAN	54	*
12 421155-005	INSTRUCTION BOOK (STARLET) SWEDISH	54	*
12 421155-006	INSTRUCTION BOOK (STARLET) DANISH	54	*
12 421155-007	INSTRUCTION BOOK (STARLET) FINNISH	54	*
12 421155-008	INSTRUCTION BOOK (STARLET) DUTCH	54	*
12 421155-009	INSTRUCTION BOOK (STARLET) SPANISH	54	*
12 421155-010	INSTRUCTION BOOK (STARLET) PORTUGUESE	54	*
12 421186-001	INSTRUCTION BOOK (GENIE 2) ENGLISH	54	*
12 421186-002	INSTRUCTION BOOK (GENIE 2) FRENCH	54	*
13 421176	ATTACHMENT SET COMPLETE (STARLET)	54	*
13 421196	ATTACHMENT SET COMPLETE (GENIE 2)	54	*
14 171469 ✓	ATTACHMENT PJUCH	54	*
15 319914 ✓	SPOOL PIN WASHER FELT	54	*
16 172336 ✓	ROTATING HOOK BOBBIN	56	*
17 103488	NEEDLE PACK (GENIE)	*	
17 103489 ✓	NEEDLE PACK (STARLET)	*	
18 381213 ✓	BLINDSTITCH GUIDE	34	*
19 171493 ✓	SPECIAL PRESSER FOOT PLATE	34	*
20 507836 ✓	PRESSER FOOT PLATE	34	*
23 421048-451	CLOTH PLATE COMPLETE	54	*
24 421054-451	CLOTH PLATE LOCKING LEVER	54	*
25 179878	CLOTH PLATE LOCKING LEVER SPRING	54	*
26 514667-451	CLOTH PLATE LOCKING LEVER STOP SCREW	54	*
27 421032	CLOTH PLATE LOCKING LEVER STOP	58	*

22 312392 Feed cover plate

