

SINGER
3000 Series

LIST OF PARTS

FASHION MATTE

Series 3000

HOUSEHOLD SEWING MACHINE

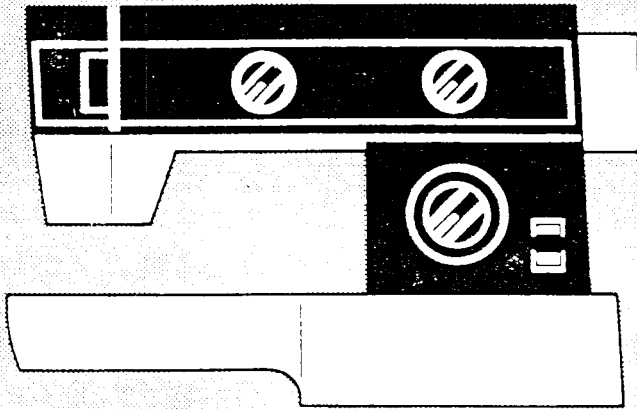
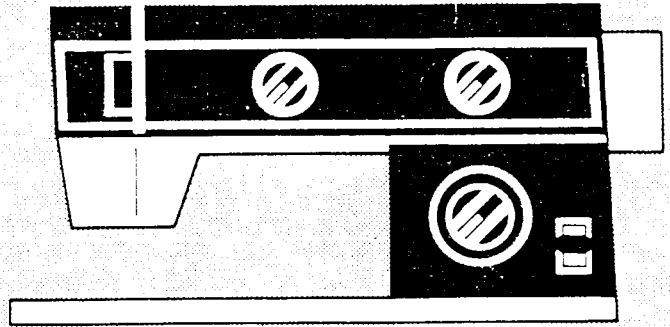

by **SINGER***



A Publication of Product Support
International Group Engineering

Part No. 119645-001

Copyright © 1983 THE SINGER COMPANY
All Rights Reserved Throughout the World

*A Trademark of THE SINGER COMPANY

INDEX

PAGE NO.	SUBASSEMBLY
1,2	ATTACHMENT SET
3,4	COVERS AND ADD ONS (A)
9,10	COVERS AND ADD ONS (B)
11,12	SHUTTLE MECHANISM
13,14	ARMSHAFT, HANDWHEEL
15,16	TENSION MECHANISM
17,18	HEAD END MODULE
19,20	FEED MECHANISM (A)
21,22	FEED MECHANISM (B)
23,24	FEED MECHANISM (C)
25,26	FEED MECHANISM (D)
27,28	CAM CONTROL MECHANISM (A)
29,30	CAM CONTROL MECHANISM (B)
31,32	CAM CONTROL MECHANISM (C)
33,34	ELECTRICAL EQUIPMENT
35,36	OPTIONAL PARTS

ATTACHMENT SET

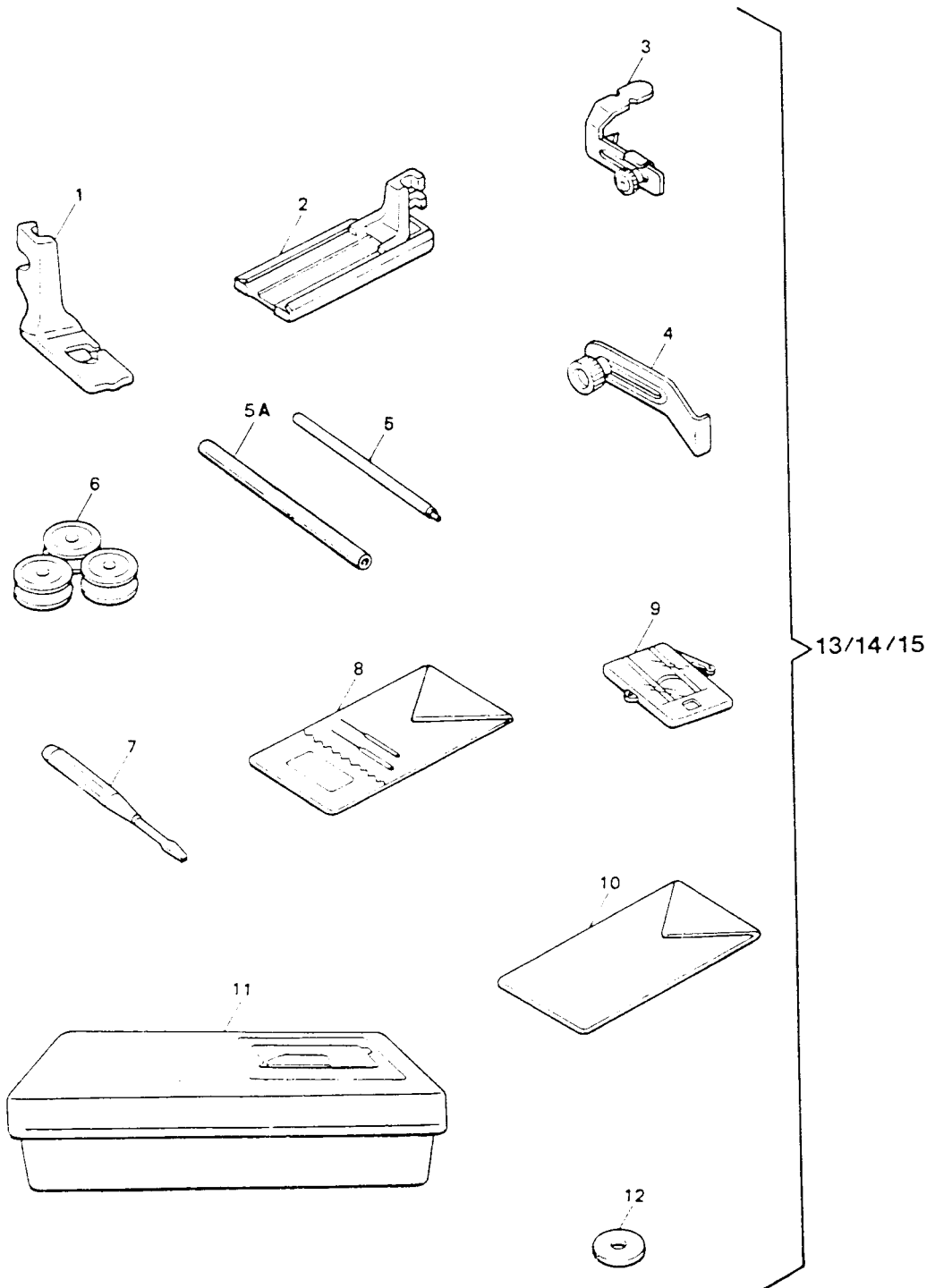

ATTACHMENT SET

REF.	SINGER PART #	ATTACHMENT SET	3 3 3 3 3					3 3 3 3 3						
			0 0 0 0 0	0 0 0 0 0	0 0 0 0 0	1 1 1 1 1	1 2 3 4 5	1 2 3 4 5						
1	1 7 6 6 3 7	BUTTONHOLE FOOT (FOR MANUAL B/H)	x	x					x	x				
2	1 7 6 6 4 6	BUTTONHOLE FOOT 171900			x	x	x				x	x	x	
3	1 7 6 6 3 9	ZIPPER FOOT	x	x	x	x	x		x	x	x	x	x	
4	1 7 6 6 4 0	SEAM GUIDE	x	x	x	x	x		x	x	x	x	x	
5	1 7 6 6 4 1	PLASTIC SPOOL PIN	x	x	x	x	x		x	x	x	x	x	
5 A	1 7 1 8 7 2	SPOOL EXTENDER	x	x	x	x	x		x	x	x	x	x	
6	1 7 6 6 4 2	BOBBINS	x	x	x	x	x		x	x	x	x	x	
7	1 7 6 6 4 3	SCREW DRIVER	x	x	x	x	x		x	x	x	x	x	
8	1 7 6 6 4 5	NEEDLE PACK	x	x	x	x	x		x	x	x	x	x	
9	1 7 6 6 4 7	FEED COVER PLATE (PLASTIC) (SNAP-ON)	x	x	x	x	x		x	x	x	x	x	
1 0	1 7 7 2 1 7	TWIN NEEDLE				x	x					x	x	
1 1	1 7 6 6 4 8	ATTACHMENT BOX (EMPTY)	x	x	x	x	x		x	x	x	x	x	
1 2	1 7 6 6 4 9	FELT WASHER	x	x	x	x	x		x	x	x	x	x	
1 3	1 7 7 2 1 8	ATTACHMENT COMPLETE SET	x	x					x	x				
1 4	1 7 7 2 1 9	ATTACHMENT COMPLETE SET			x						x			
1 5	1 7 7 2 2 0	ATTACHMENT COMPLETE SET			x	x					x	x		
1 6	119632001	INST BOOK 3001/3011 NO.1 (E/F/S)	x						x					
1 7	119632002	INST BOOK 3001/3011 NO.2 (G/I/D)	x						x					
1 8	119633001	INST BOOK 3002/3012 NO.1 (E/F/S)		x						x				
1 9	119634001	INST BOOK 3003/3013 NO.1 (E/F/S)		x						x				
2 0	119634002	INST BOOK 3003/3013 NO.2 (G/I/D)			x						x			
2 1	119634003	INST BOOK 3003/3013 NO.3 (N/S/FIN)			x						x			
2 2	119635001	INST BOOK 3004/3014 NO.1 (E/F/S)				x						x		
2 3	119635002	INST BOOK 3004/3014 NO.2 (G/I/D)				x						x		
2 4	119635003	INST BOOK 3004/3014 NO.3 (N/S/FIN)				x						x		
2 5	119636001	INST BOOK 3005/3015 NO.1 (E/F/S)					x						x	
2 6	119637001	USA GUARANTEE CARD (M BY S)	x	x	x	x	x		x	x	x	x	x	
2 7	119640900	USA 3011 REGISTRATION CARD									x			
2 8	119640900	USA 3014 REGISTRATION CARD											x	
2 9	119640900	USA 3013 REGISTRATION CARD											x	
3 0	119640900	USA 3012 REGISTRATION CARD											x	
3 1	119640900	USA 3015 REGISTRATION CARD												x
3 2	1 1 9 5 7 4	DANISH INSERTION (DENMARK)			x	x					x	x		

COVERS AND ADD ONS (A)

REF.	SINGER PART #	COVERS AND ADD ONS (A)	3 3 3 3 3					3 3 3 3 3				
			0	0	0	0	0	0	0	0	0	0
			1	2	3	4	5	1	2	3	4	5
1	1 7 7 2 2 2	ARM TOP COVER (STANDARD)	x	x	x	x	x	x	x	x	x	x
1	1 7 7 2 2 3	ARM TOP COVER WITH HANDLE	x	x	x	x	x	x	x	x	x	x
1A	1 7 7 2 2 4	ARM TOP COVER	x	x	x	x	x	x	x	x	x	x
2	1 7 7 2 2 5	HANDLE	x	x	x	x	x	x	x	x	x	x
3	1 7 7 1 1 5	HANDLE PIN	x	x	x	x	x	x	x	x	x	x
4	1 7 7 2 2 6	HANDLE PIN	x	x	x	x	x	x	x	x	x	x
5	1 7 7 1 1 6	SPRING WASHER	x	x	x	x	x	x	x	x	x	x
6	1 7 7 1 1 7	RETAINER (2)	x	x	x	x	x	x	x	x	x	x
7	1 7 7 2 2 7	RETAINING RING	x	x	x	x	x	x	x	x	x	x
8	1 7 6 6 5 3	ARM TOP COVER SCREW (L) - 177385	x	x	x	x	x	x	x	x	x	x
9	1 7 6 6 5 7	ARM TOP COVER SCREW (R) - 177386	x	x	x	x	x	x	x	x	x	x
10	1 7 6 6 5 8	BOBBIN PRESSER SCREW 177388	x	x	x	x	x	x	x	x	x	x
11	1 7 6 6 5 9	BOBBIN PRESSER	x	x	x	x	x	x	x	x	x	x
12	1 7 6 6 6 0	OIL THROUGH	x	x	x	x	x	x	x	x	x	x
13	1 7 6 6 6 1	OIL THROUGH RETAINING RING	x	x	x	x	x	x	x	x	x	x
14	1 7 6 6 6 2	BOBBIN WINDER COMPLETE	x	x	x	x	x	x	x	x	x	x
15	1 7 6 6 6 3	BOBBIN WINDER SHAFT RING	x	x	x	x	x	x	x	x	x	x
16	1 7 6 6 6 4	BOBBIN WINDER MOUNTING SPRING	x	x	x	x	x	x	x	x	x	x
17	1 7 6 6 6 5	BOBBIN WINDER BRACKET ASSEMBLY	x	x	x	x	x	x	x	x	x	x
18	1 7 6 6 6 6	BOBBIN WINDER BRACKET STUD SCREW	x	x	x	x	x	x	x	x	x	x
19	1 7 6 6 6 7	BOBBIN WINDER BRACKET RUBBER RING	x	x	x	x	x	x	x	x	x	x
20	1 7 6 6 6 8	CONTROL PANEL RETAINING WASHER (2)	x	x	x	x	x	x	x	x	x	x
21	1 7 6 6 6 9	CONTROL PANEL WASHER (2)	x	x	x	x	x	x	x	x	x	x
22	1 7 7 2 2 8	CONTROL DIAL (3001/3011) (2)	x									
22	1 7 7 2 2 9	CONTROL DIAL (3002/3012) (1)		x								
22	1 7 7 2 3 0	CONTROL DIAL (3003/3013) (2)			x							
22	1 7 7 2 3 1	CONTROL DIAL (3004/3014) (2)				x						
22	1 7 7 2 3 2	CONTROL DIAL (3005/3015) (2)					x					
23	1 7 6 6 7 4	CONTROL DIAL NYLON WASHER	x	x	x	x	x	x	x	x	x	x
24	1 7 6 6 7 5	CONTROL DIAL WASHER	x	x	x	x	x	x	x	x	x	x
25	1 7 6 6 7 6	CONTROL DIAL SET SCREW	x	x	x	x	x	x	x	x	x	x
26	1 7 7 2 3 3	CONTROL KNOB (3001/3011)	x									
26	1 7 7 2 3 4	CONTROL KNOB (3002/3012)		x								
27	1 7 7 2 3 5	CONTROL DIAL NYLON WASHER	x	x								
28	1 7 6 6 8 0	CONTROL KNOB WASHER	x	x								
29	1 7 6 6 8 1	CONTROL KNOB SET SCREW	x	x								
30	1 7 7 2 3 6	SELECTOR DIAL INDICATION RING(3004/3014)					x					x
30	1 7 7 2 3 7	SELECTOR DIAL INDICATION RING(3003/3013)					x					x
30	1 7 7 2 3 8	SELECTOR DIAL INDICATION RING(3002/3012)					x					x
30	1 7 7 2 3 9	SELECTOR DIAL INDICATION RING(3005/3015)						x				x
31	1 7 7 2 4 0	PATTERN SELECTOR DIAL (3004/3014)						x				x
31	1 7 7 2 4 1	PATTERN SELECTOR DIAL (3003/3013)						x				x
31	1 7 7 2 4 2	PATTERN SELECTOR DIAL (3002/3012)						x				x
31	1 7 7 2 4 3	PATTERN SELECTOR DIAL (3005/3015)							x			x
32	1 7 7 2 4 4	PATTERN SELECTOR DIAL SHAFT ASSEMBLY							x			x

77385
77386
77388

COVERS AND ADD ONS (A)

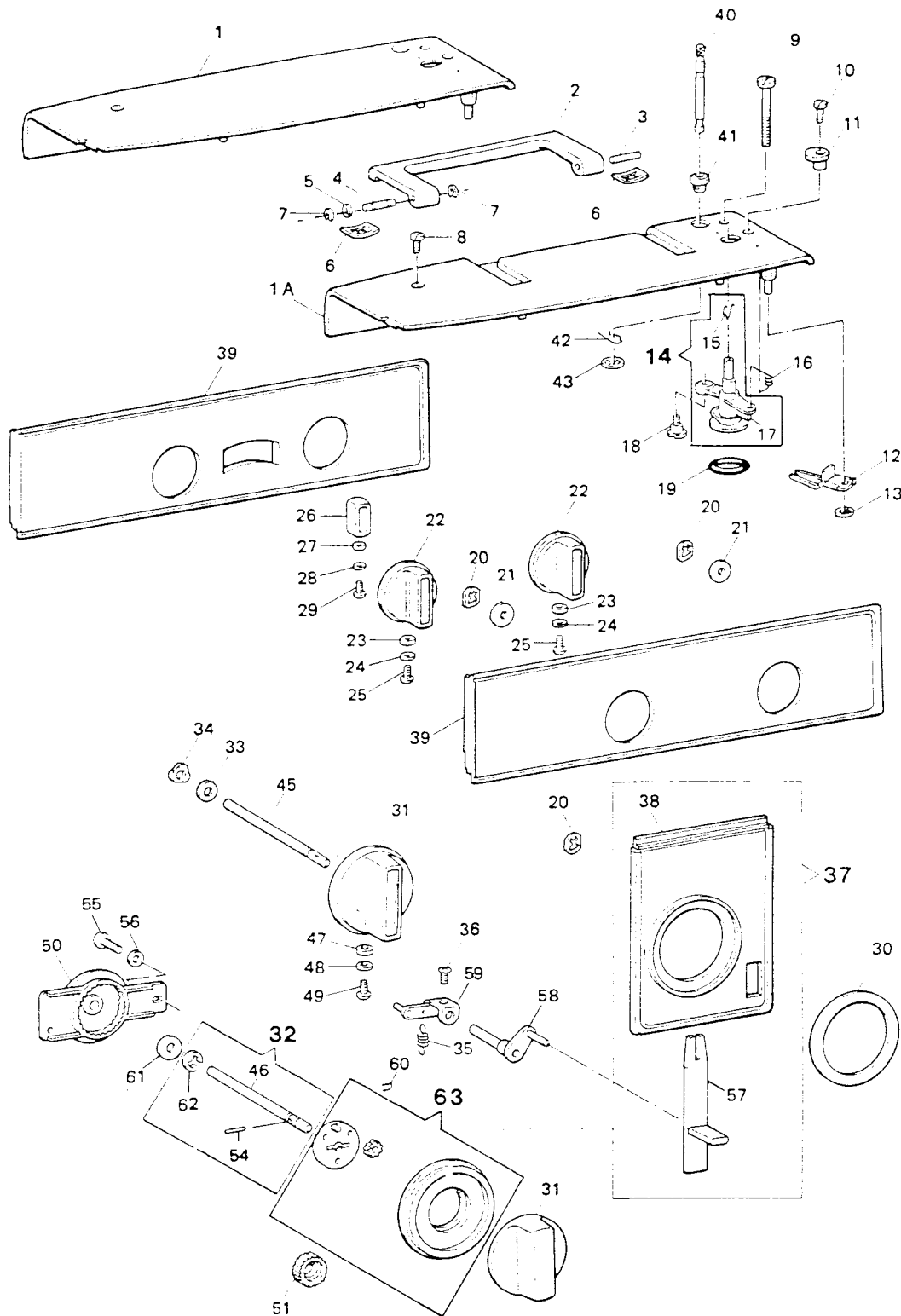

COVERS AND ADD ONS (A)

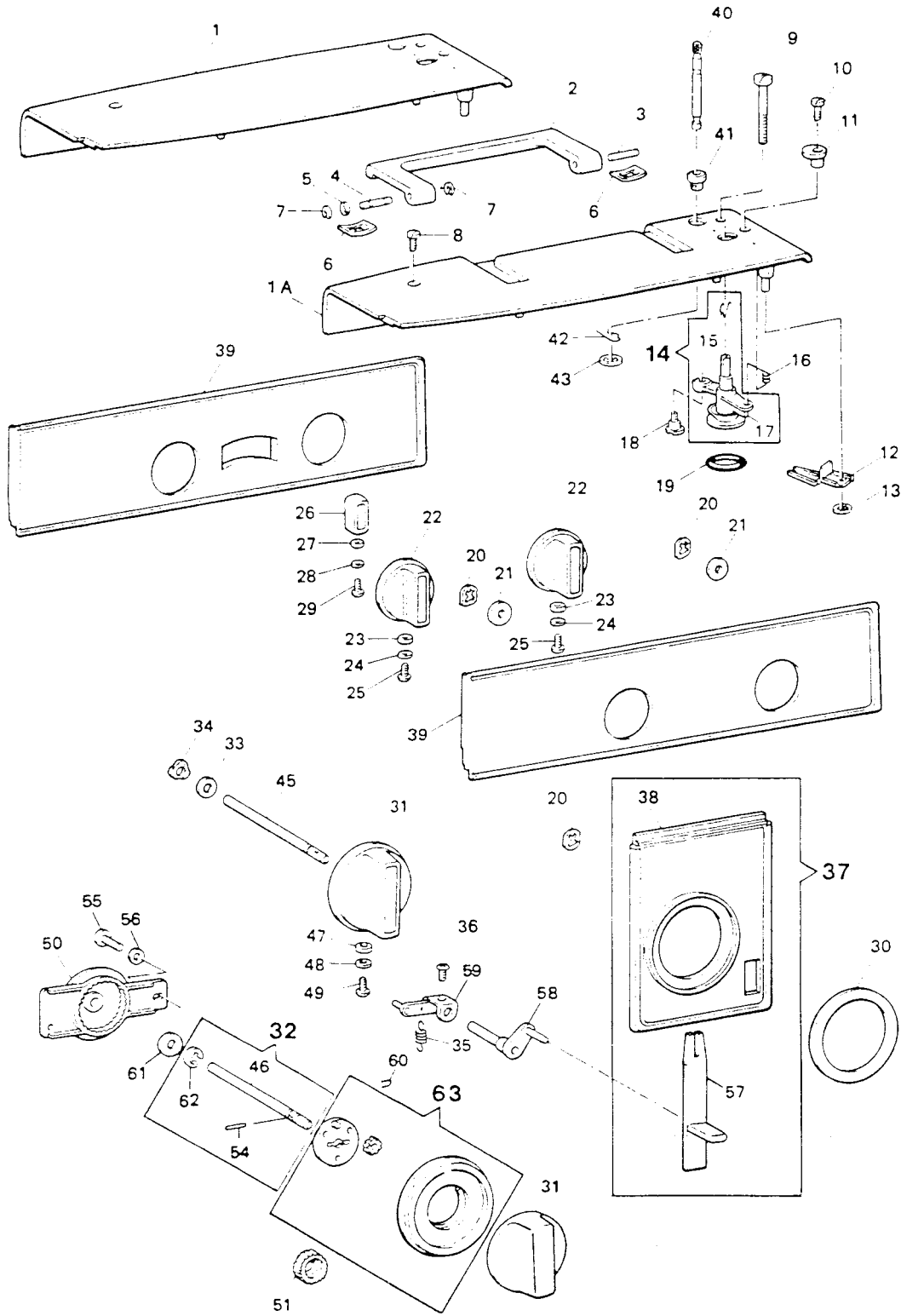

COVERS AND ADD ONS (A)

2215
 22000
 MS
 2020L
 HCY
 77372
 77371
 77370
 77369
 77373
 77374
 77377
 77378
 77380
 77377
 77369
 77368
 77376
 77375

REF.	SINGER PART #	COVERS AND ADD ONS (A)	3 3 3 3 3					3 3 3 3 3				
			0	0	0	0	0	0	0	0	0	0
			1	2	3	4	5	1	2	3	4	5
33	176691	PATTERN SELECTOR DIAL SHAFT WASHER					x					x
34	176692	PATTERN SELECTOR DIAL SHAFT RETAINING RING					x					x
35	176693	FEED REGULATING LEVER BRACKET SPRING	x	x	x	x	x	x	x	x	x	x
36	176695	FEED REGULATING BRACKET SET SCREW	x	x	x	x	x	x	x	x	x	x
37	177245	ARM PANEL ASSEMBLY					x					(x)
37	177246	ARM PANEL ASSEMBLY					x					(x)
37	177247	ARM PANEL ASSEMBLY					x					(x)
37	177248	ARM PANEL ASSEMBLY (MERRITT BY SINGER)	x								(x)	
37	177249	ARM PANEL ASSEMBLY										(x)
38	177250	ARM PANEL										(x)
38	177251	ARM PANEL										(x)
38	177252	ARM PANEL										(x)
38	177253	ARM PANEL										(x)
38	177254	ARM PANEL (MERRITT BY SINGER)	x								(x)	
38	177255	ARM PANEL ASSEMBLY (MERRITT)	x								(x)	
38	177256	ARM PANEL ASSEMBLY (SINGER)	x								(x)	
38	177257	ARM PANEL (MERRITT)	x								(x)	
38	177258	ARM PANEL (SINGER)	x								(x)	
39	177259	CONTROL PANEL 3001	x									
39	177260	CONTROL PANEL 3002 MERRITT BY SINGER						x				
39	177261	CONTROL PANEL 3003 MERRITT BY SINGER							x			
39	177262	CONTROL PANEL 3004 MERRITT BY SINGER								x		
39	177263	CONTROL PANEL 3005 MERRITT BY SINGER									x	
39	177264	CONTROL PANEL 3011									x	
39	177265	CONTROL PANEL 3012 MERRITT BY SINGER										x
39	177266	CONTROL PANEL 3013 MERRITT BY SINGER										x
39	177267	CONTROL PANEL 3014 MERRITT BY SINGER										x
39	177268	CONTROL PANEL 3015 MERRITT BY SINGER										x
39	177269	CONTROL PANEL 3002 MERRITT						x				
39	177270	CONTROL PANEL 3003 MERRITT							x			
39	177271	CONTROL PANEL 3004 MERRITT								x		
39	177272	CONTROL PANEL 3005 MERRITT									x	
39	177273	CONTROL PANEL 3012 MERRITT									x	
39	177274	CONTROL PANEL 3013 MERRITT										x
39	177275	CONTROL PANEL 3014 MERRITT										x
39	177276	CONTROL PANEL 3015 MERRITT										x
39	177278	CONTROL PANEL 3002 SINGER						x				
39	177279	CONTROL PANEL 3003 SINGER							x			
39	177280	CONTROL PANEL 3004 SINGER								x		
39	177281	CONTROL PANEL 3005 SINGER									x	
39	177282	CONTROL PANEL 3012 SINGER									x	
39	177283	CONTROL PANEL 3013 SINGER										x
39	177284	CONTROL PANEL 3014 SINGER										x
39	177285	CONTROL PANEL 3015 SINGER										x
40	177286	SPOOL PIN	x	x	x	x	x	x	x	x	x	x

77372
 77371
 77370
 77369
 77373
 77374
 77377
 77378
 77380
 77377
 77369
 77368
 77376
 77375

COVERS AND ADD ONS (A)

REF.	SINGER PART #	COVERS AND ADD ONS (A)	3 3 3 3 3					3 3 3 3 3				
			0	0	0	0	0	0	0	0	0	0
			1	2	3	4	5	1	2	3	4	5
4 1	1 7 7 2 8 7	SPOOL PIN STAND	X	X	X	X	X	X	X	X	X	X
4 2	1 7 7 2 8 8	SPOOL PIN SPRING	X	X	X	X	X	X	X	X	X	X
4 3	1 7 7 2 8 9	STOP RING	X	X	X	X	X	X	X	X	X	X
4 5	1 7 7 2 9 1	PATTERN SELECTOR DIAL SHAFT	X	X	X			X	X	X		
4 6	1 7 7 2 9 2	PATTERN SELECTOR DIAL SHAFT					X					X
4 7	1 7 7 2 9 3	PATTERN SELECTOR DIAL SHAFT NYLON WASHER	X	X	X	X		X	X	X	X	
4 8	1 7 7 2 9 4	PATTERN SELECTOR DIAL SHAFT WASHER	X	X	X	X		X	X	X	X	
4 9	1 7 7 2 9 5	PATTERN SELECTOR DIAL SHAFT SET SCREW	X	X	X	X		X	X	X	X	
5 0	1 7 7 2 9 6	WHEEL					X					X
5 1	1 7 7 2 9 7	DRIVE GEAR					X					X
5 4	1 7 7 3 0 0	SPRING PIN					X					X
5 5	1 7 7 3 0 1	SCREW					X					X
5 6	1 7 7 3 0 2	WASHER					X					X
5 7	1 7 7 3 0 3	FEED REGULATING SLIDE PLATE					X					X
5 7	1 7 7 3 0 4	FEED REGULATING SLIDE PLATE	X					X				
5 7	1 7 7 3 0 5	FEED REGULATING SLIDE PLATE		X					X			
5 7	1 7 7 3 0 6	FEED REGULATING SLIDE PLATE					X			X		
5 7	1 7 7 3 0 7	FEED REGULATING SLIDE PLATE						X				X
5 8	1 7 7 3 0 8	FEED REGULATING LEVER ASSEMBLY	X	X	X	X	X	X	X	X	X	X
5 9	1 7 7 3 0 9	FEED REGULATING LEVER ARM ASSEMBLY	X	X	X	X	X	X	X	X	X	X
6 0	1 7 7 3 1 0	SPRING					X					X
6 1	1 7 7 3 1 1	WASHER					X					X
6 2	1 7 7 3 1 2	RETAINING RING					X					X
6 3	1 7 7 3 6 6	PLATE ASSEMBLY					X					X

77337
77332

COVERS AND ADD ONS (A)

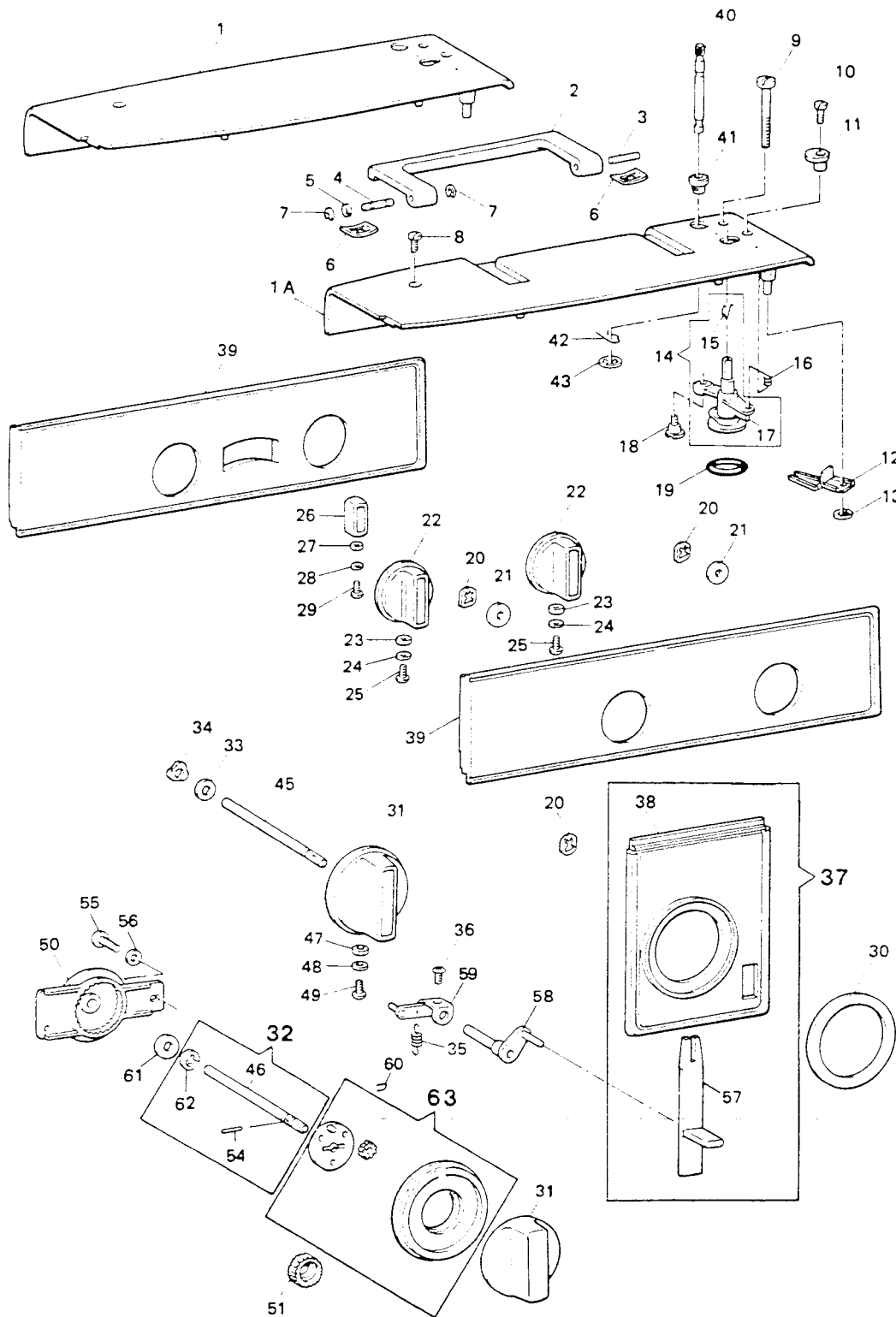

COVERS AND ADD ONS (B)

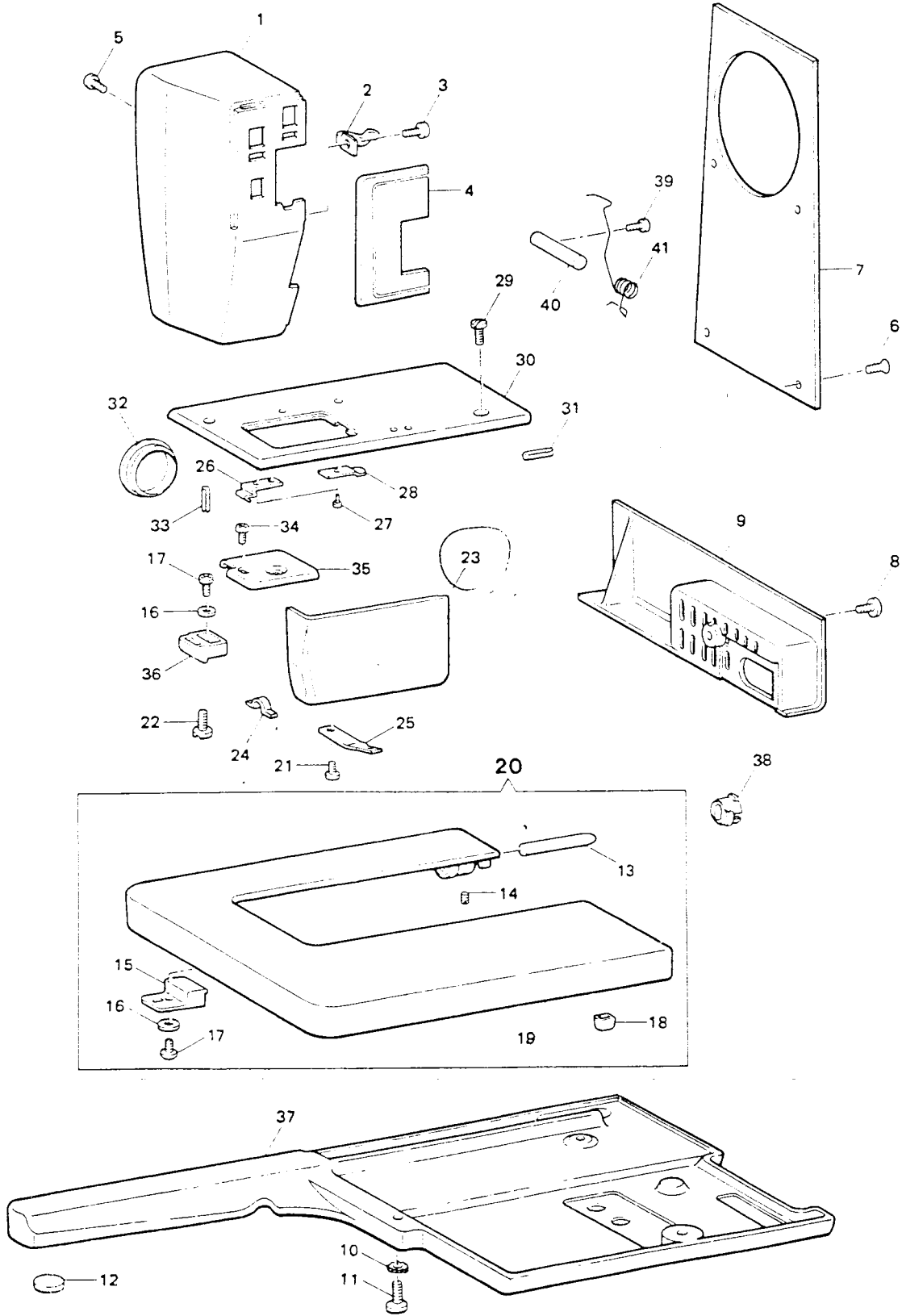

COVERS AND ADD ONS (B)

REF.	SINGER PART #	COVERS AND ADD ONS (B)	3 3 3 3 3					3 3 3 3 3				
			0	0	0	0	0	0	0	0	0	0
			1	2	3	4	5	1	2	3	4	5
1	1 7 7 3 1 3	FACE PLATE (WITH LOCKING) EUROPE	x	x	x	x	x	x	x	x	x	x
1	1 7 7 3 1 4	FACE PLATE (WITH LOCKING) UL/CSA	x	x	x	x	x	x	x	x	x	x
2	1 7 6 7 1 6	FACE PLATE HINGE SPRING	x	x	x	x	x	x	x	x	x	x
3	1 7 6 7 1 7	FACE PLATE HINGE SPRING SCREW	x	x	x	x	x	x	x	x	x	x
4	1 7 7 3 1 5	FACE PLATE PANEL (3001/3011)	x						x			
4	1 7 7 3 1 6	FACE PLATE PANEL (3002/3012)		x						x		
4	1 7 7 3 1 7	FACE PLATE PANEL (3003/3013)			x						x	
4	1 7 7 3 1 8	FACE PLATE PANEL (3004/3014)				x						x
4	1 7 7 3 1 9	FACE PLATE PANEL (3005/3015)					x					x
5	1 7 7 3 2 0	FACE PLATE LOCKING SCREW	x	x	x	x	x	x	x	x	x	x
6	1 7 7 3 2 1	ARM END COVER PLATE MOUNTING SCREW (4)	x	x	x	x	x	x	x	x	x	x
7	1 7 7 3 2 2	ARM END COVER PLATE	x	x	x	x	x	x	x	x	x	x
8	1 7 6 7 2 9	MOTOR COVER PLATE MOUNTING SCREW							x	x	x	x
9	1 7 7 3 2 3	MOTOR COVER PLATE							x	x	x	x
10	1 7 6 7 3 1	STAR WASHER (3)							x	x	x	x
11	1 7 6 7 3 2	SCREW (3)							x	x	x	x
12	1 7 6 7 3 3	RUBBER CUSHION FOR BASE PLATE (4)							x	x	x	x
13	1 7 6 7 3 4	GUIDE PIN (2)							x	x	x	x
14	1 7 6 7 3 5	GUIDE PIN SET SCREW (2)							x	x	x	x
15	1 7 6 7 5 6	LATCH HOLDER							x	x	x	x
16	1 7 6 7 4 3	WASHER							x	x	x	x
17	1 7 6 6 8 8	LATCH SCREW							x	x	x	x
18	1 7 6 7 3 8	RUBBER CUSHION (2)							x	x	x	x
19	1 7 7 3 2 4	ACCESSORY TABLE							x	x	x	x
20	1 7 6 7 3 9	ACCESSORY TABLE COMPLETE (177383)							x	x	x	x
21	1 7 1 8 5 9	HINGED DOOR SPRING SET SCREW							x	x	x	x
22	1 7 6 7 4 2	SCREW (2) (HEAD HINGE)	x	x	x	x	x	x				
23	1 7 6 7 4 4	HINGED DOOR W/LA							x	x	x	x
24	1 7 6 7 4 5	HINGED PLATE							x	x	x	x
25	1 7 6 7 4 6	HINGED DOOR SPRING							x	x	x	x
26	1 7 6 7 4 7	NEEDLE PLAP A G E G (LEFT)							x	x	x	x
27	1 7 6 7 4 8	NEEDLE PLATE SPRING SET SCREW (2)							x	x	x	x
28	1 7 6 7 4 9	NEEDLE PLATE SPRING (RIGHT)							x	x	x	x
29	1 7 6 7 5 0	UPPER PLATE MOUNTING SCREW (2) 177387							x	x	x	x
30	1 7 6 7 5 1	UPPER PLATE							x	x	x	x
31	1 7 6 7 5 2	SPRING PIN	x	x	x	x	x	x	x	x	x	x
32	1 7 6 7 5 3	COVER PLUG (LARGE)							x	x	x	x
33	1 7 6 7 5 4	SPRING PIN							x	x	x	x
34	1 7 6 7 1 7	BEVEL GEAR COVER MOUNTING SCREW							x	x	x	x
35	1 7 6 7 5 5	BEVEL GEAR COVER							x	x	x	x
36	1 7 6 7 3 6	ACCESSORY TABLE LATCH							x	x	x	x
37	1 7 1 8 5 1	BASE PLATE							x	x	x	x
38	1 7 7 3 2 5	LATCH HOLDER							x	x	x	x
39	1 7 6 7 2 5	STUD SET SCREW	x						x			
40	1 7 6 7 2 6	SPRING HOLDER STUD	x						x			
41	1 7 6 7 2 7	SPRING	x	x	x	x	x	x	x	x	x	x

77387

SHUTTLE MECHANISM

REF.	SINGER PART #	SHUTTLE MECHANISM	3 3 3 3 3					3 3 3 3 3				
			0	0	0	0	0	0	0	0	0	0
			1	2	3	4	5	1	2	3	4	5
1	1 7 6 7 5 7	SHUTTLE DRIVER SHAFT BEARING	x	x	x	x	x					
2	1 7 6 7 5 8	SHUTTLE DRIVER SHAFT BEARING SET SCREW	x	x	x	x	x					
3	1 7 6 7 5 9	SHUTTLE DRIVER SHAFT BEVEL GEAR SET SCREW							x	x	x	x
3	1 7 6 7 3 5	SHUTTLE DRIVER SHAFT BEVEL GEAR SET SCREW	x	x	x	x	x					
4	1 7 6 7 6 0	SHUTTLE DRIVER SHAFT BEVEL GEAR							x	x	x	x
4	1 7 6 7 6 1	SHUTTLE DRIVER SHAFT BEVEL GEAR	x	x	x	x	x					
5	1 7 6 7 6 2	SHUTTLE DRIVER SHAFT COLLAR SET SCREW	x	x	x	x	x					
6	1 7 6 7 6 3	SHUTTLE DRIVER SHAFT BEVEL GEAR SET SCREW							x	x	x	x
6	1 7 6 7 6 4	SHUTTLE DRIVER SHAFT BEVEL GEAR SET SCREW	x	x	x	x	x					
7	1 7 6 7 3 5	SHUTTLE DRIVER SHAFT COLLAR SET SCREW	x	x	x	x	x		x	x	x	x
8	1 7 6 7 6 5	SHUTTLE DRIVER SHAFT COLLAR							x	x	x	x
9	1 7 6 7 6 6	SHUTTLE DRIVER SHAFT SET SCREW	x	x	x	x	x		x	x	x	x
10	1 7 6 7 6 7	SHUTTLE DRIVER SET SCREW (2)							x	x	x	x
11	1 7 6 7 5 8	SHUTTLE DRIVER SET SCREW	x	x	x	x	x					
12	1 7 6 7 6 8	SHUTTLE RACE TOP SPRING							x	x	x	x
13	1 7 6 7 6 9	SHUTTLE RACE TOP SPRING MOUNTING SCREW (2)							x	x	x	x
14	1 7 6 7 7 0	SHUTTLE RACE PIN (2)							x	x	x	x
15	1 7 6 7 7 1	SHUTTLE RACE BODY							x	x	x	x
16	1 7 6 7 7 2	SHUTTLE RACE RING							x	x	x	x
17	1 7 6 7 7 3	SHUTTLE LEVER. RIHNG	x	x	x	x	x		x	x	x	x
18	1 7 6 7 7 4	SHUTTLE RACE RING PING PIN (2)	x	x	x	x	x		x	x	x	x
19	1 7 6 7 7 5	SHUTTLE LEVER WASHER (2)							x	x	x	x
20	1 7 6 7 7 6	SHUTTLE LEVER. LEFT	x	x	x	x	x		x	x	x	x
21	1 7 6 7 7 7	SHUTTLE LEVER SPRING (2)	x	x	x	x	x		x	x	x	x
22	1 7 6 7 7 8	SHUTTLE LEVER STUD SCREW (2)	x	x	x	x	x		x	x	x	x
23	1 7 6 7 7 9	SHUTTLE RACE ASSEMBLY							x	x	x	x
24	1 7 6 7 8 0	SHUTTLE DRIVER							x	x	x	x
25	1 7 6 7 8 1	SHUTTLE DRIVER ASSEMBLY							x	x	x	x
26	1 7 6 7 8 2	SHUTTLE DRIVER SPRING SCREW (2)	x	x	x	x	x		x	x	x	x
27	1 7 6 7 8 3	SHUTTLE DRIVER SPRING							x	x	x	x
28	1 7 6 7 8 4	SHUTTLE DRIVER HOOK	x	x	x	x	x		x	x	x	x
29	1 7 6 7 8 5	BOBBIN	x	x	x	x	x		x	x	x	x
30	1 7 6 7 8 6	BOBBIN CASE ASSEMBLY	x	x	x	x	x		x	x	x	x
31	1 7 6 7 8 7	SHUTTLE DRIVER	x	x	x	x	x					
32	1 7 6 7 8 8	SHUTTLE DRIVER ASSEMBLY	x	x	x	x	x					
33	1 7 6 7 8 9	SHUTTLE DRIVER	x	x	x	x	x					
34	1 7 6 7 9 0	SHUTTLE RACE TOP SPRING	x	x	x	x	x					
35	1 7 6 7 9 1	SHUTTLE RACE TOP SPRING MOUTING SCREW (2)	x	x	x	x	x					
36	1 7 6 7 9 2	SHUTTLE RACE BODY	x	x	x	x	x					
37	1 7 6 7 9 3	SHUTTLE RACE ASSEMBLY	x	x	x	x	x					
38	1 7 6 7 1 7	LOWER SHAFT BEVEL GEAR COVER SCREW (3)	x	x	x	x	x					
39	1 7 6 7 9 4	LOWER BEVEL GEAR COVER	x	x	x	x	x					
40	1 7 6 7 9 5	LOWER SHAFT BEVEL GEAR COVER FIBER GASKET	x	x	x	x	x					

71893

NO

71897

SHUTTLE MECHANISM

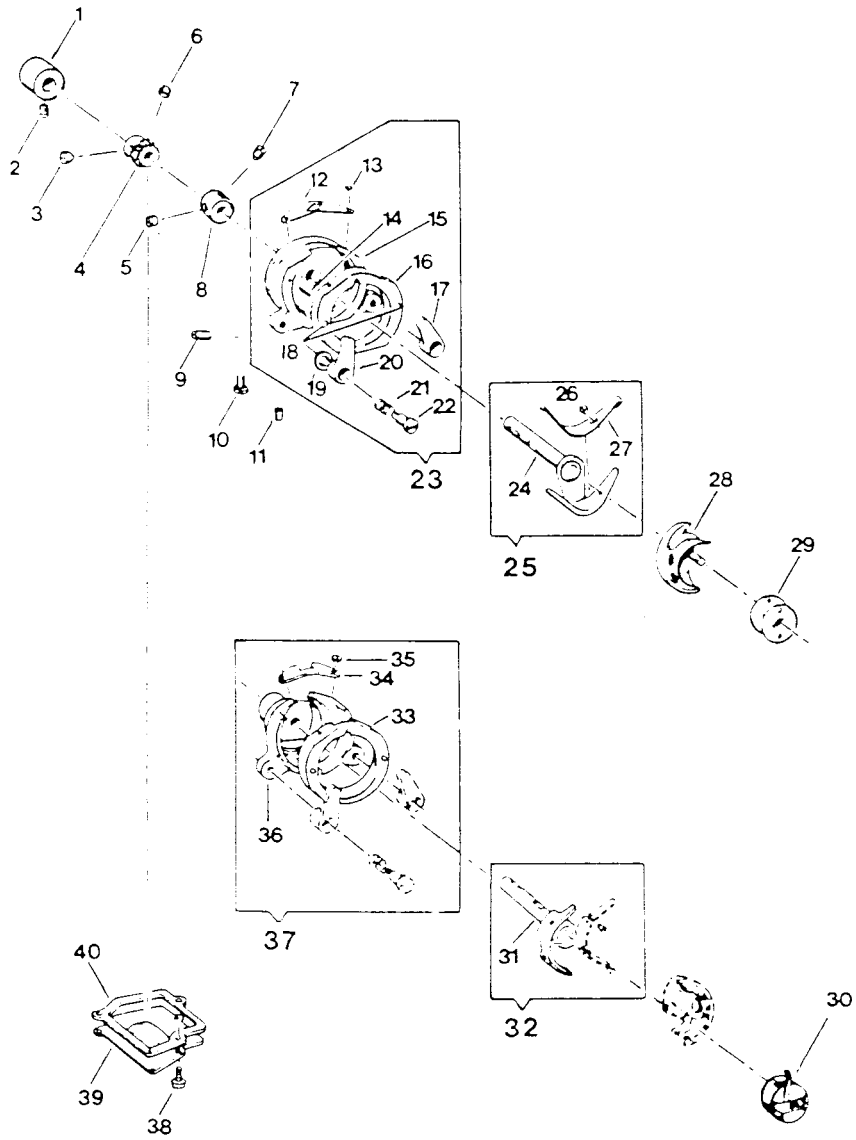

ARMSHAFT, HANDWHEEL

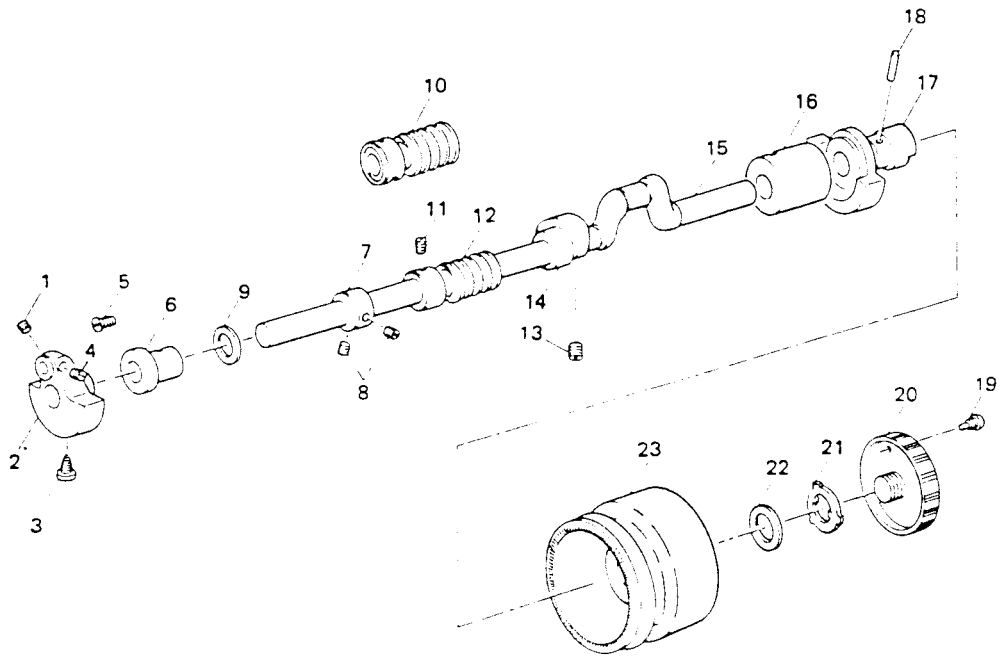

ARMSHAFT, HANDWHEEL

REF.	SINGER PART #	ARMSHAFT, HANDWHEEL	3 3 3 3 3					3 3 3 3 3					
			0	0	0	0	0	0	0	0	0	0	
			1	2	3	4	5	1	2	3	4	5	
1	1 7 6 7 9 6	ECCENTRIC COUNTER WEIGHT SET SCREW	x	x	x	x	x	x	x	x	x	x	
2	1 7 6 7 9 7	ECCENTRIC COUNTER WEIGHT								x	x	x	x
2	1 7 6 7 9 8	ECCENTRIC COUNTER WEIGHT	x	x	x	x	x						
3	1 7 6 7 9 9	ECCENTRIC COUNTER WEIGHT SCREW	x	x	x	x	x			x	x	x	x
4	1 7 6 8 0 0	ECCENTRIC COUNTER WEIGHT SET SCREW	x	x	x	x	x			x	x	x	x
5	1 7 6 8 0 1	SET SCREW (2)	x	x	x	x	x			x	x	x	x
6	1 7 6 8 0 2	UPPER SHAFT BUSHING LEFT	x	x	x	x	x			x	x	x	x
7	1 7 6 8 0 3	COLLAR	x	x	x	x	x			x	x	x	x
8	1 7 6 7 6 3	COLLAR SET SCREW (2)	x	x	x	x	x			x	x	x	x
9	1 7 1 8 5 8	NYLON WASHER	x	x	x	x	x			x	x	x	x
10	1 7 6 8 0 4	SPIRAL GEAR	x							x			
11	1 7 6 8 0 6	GEAR SET SCREW (2)	x							x			
11	1 7 6 8 0 5	GEAR SET SCREW (2)		x	x	x	x			x	x	x	x
12	1 7 6 8 0 7	WORM GEAR		x	x	x	x			x	x	x	x
13	1 7 6 8 0 8	FEED CAM SET SCREW	x	x	x	x	x			x	x	x	x
14	1 7 6 8 0 9	FEED CAM	x	x	x	x	x			x	x	x	x
15	1 7 6 8 1 0	ARM SHAFT								x	x	x	x
15	1 7 6 8 1 1	ARM SHAFT	x	x	x	x	x						
16	1 7 6 8 1 2	UPPER SHAFT BUSHING. RIGHT	x	x	x	x	x			x	x	x	x
17	1 7 6 8 1 3	HANDWHEEL BUSHING	x	x	x	x	x						
17	1 7 6 8 1 4	HANDWHEEL BUSHING								x	x	x	x
18	1 7 6 8 1 5	HANDWHEEL BUSHING ROOL PIN	x	x	x	x	x			x	x	x	x
19	1 7 6 8 1 6	STOP MOTION KNOB MOUNTING SCREW	x	x	x	x	x			x	x	x	x
20	1 7 7 3 2 6	STOP MOTION KNOB ASSEMBLY (3001/3011)	x							x			
20	1 7 7 3 2 7	STOP MOTION KNOB ASSEMBLY (3002/3012)		x							x		
20	1 7 7 3 2 8	STOP MOTION KNOB ASSEMBLY (3003/3013)			x							x	
20	1 7 7 3 2 9	STOP MOTION KNOB ASSEMBLY (3004/3014)				x							x
20	1 7 7 3 3 0	STOP MOTION KNOB ASSEMBLY (3005/3015)					x						x
21	1 7 6 8 1 8	STOP MOTION KNOB SCREW WASHER	x	x	x	x	x			x	x	x	x
22	1 7 6 8 1 9	STOP MOTION KNOB WASHER	x	x	x	x	x			x	x	x	x
23	1 7 6 8 2 0	HANDWHEEL	x	x	x	x	x			x	x	x	x

TENSION MECHANISM

REF.	SINGER PART #	TENSION MECHANISM	3 3 3 3 3					3 3 3 3 3				
			0 0 0 0 0	0 0 0 0 0	0 0 0 0 0	1 1 1 1 1	1 2 3 4 5	1 2 3 4 5				
1	1 7 7 3 3 1	THREAD GUARD ASSEMBLY (3001/3011)	x						x			
1	1 7 7 3 3 2	THREAD GUARD ASSEMBLY (3002/3012)		x						x		
1	1 7 7 3 3 3	THREAD GUARD ASSEMBLY (3003/3013)			x						x	
1	1 7 7 3 3 4	THREAD GUARD ASSEMBLY (3004/3014)				x						x
1	1 7 7 3 3 5	THREAD GUARD ASSEMBLY (3005/3015)					x					x
2	1 7 6 8 2 5	THREAD GUIDE MOUNTING SCREW (UPPER)	x	x	x	x	x	x	x	x	x	x
3	1 7 6 8 2 6	THREAD GUIDE ASSEMBLY (UPPER)	x	x	x	x	x	x	x	x	x	x
4	1 7 7 3 3 6	THREAD GUARD BRACKET	x	x	x	x	x	x	x	x	x	x
5	1 7 6 8 2 8	TENSION DISC	x	x	x	x	x	x	x	x	x	x
6	1 7 6 8 2 9	TENSION DISC	x	x	x	x	x	x	x	x	x	x
7	1 7 6 8 3 0	TENSION RELEASE LEVER	x	x	x	x	x	x	x	x	x	x
8	1 7 6 8 3 1	TENSION SPRING (SMALL)	x	x	x	x	x	x	x	x	x	x
9	1 7 6 8 3 2	TENSION SPRING (LARGE)	x	x	x	x	x	x	x	x	x	x
1 0	1 7 7 3 3 7	TENSION CONTROL KNOB ASSEMBLY (3001/3011)	x						x			
1 0	1 7 7 3 3 8	TENSION CONTROL KNOB ASSEMBLY (3002/3012)		x						x		
1 0	1 7 7 3 3 9	TENSION CONTROL KNOB ASSEMBLY (3003/3013)			x						x	
1 0	1 7 7 3 4 0	TENSION CONTROL KNOB ASSEMBLY (3004/3014)				x						x
1 0	1 7 7 3 4 1	TENSION CONTROL KNOB ASSEMBLY (3005/3015)					x					x
1 1	1 7 6 8 3 7	TENSION CONTROL RING	x	x	x	x	x	x	x	x	x	x
1 2	1 7 7 3 4 2	TENSION CONTROL KNOB (3001/3011)	x						x			
1 2	1 7 7 3 4 3	TENSION CONTROL KNOB (3002/3012)		x						x		
1 2	1 7 7 3 4 4	TENSION CONTROL KNOB (3003/3013)			x						x	
1 2	1 7 7 3 4 5	TENSION CONTROL KNOB (3004/3014)				x						x
1 2	1 7 7 3 4 6	TENSION CONTROL KNOB (3005/3015)					x					x
1 3	1 7 6 8 4 2	TENSION CONTROL KNOB STOPPER	x	x	x	x	x	x	x	x	x	x
1 4	1 7 6 8 4 3	CONTROL KNOB WASHER	x	x	x	x	x	x	x	x	x	x
1 5	1 7 6 8 4 4	CONTROL KNOB NUT (2)	x	x	x	x	x	x	x	x	x	x
1 6	1 7 6 8 4 5	TENSION STUD SCREW	x	x	x	x	x	x	x	x	x	x
1 7	1 7 6 8 4 6	SPRING WASHER	x	x	x	x	x	x	x	x	x	x
1 8	1 7 6 8 4 7	THREAD TAKE-UP SPRING CASE, FRONT	x	x	x	x	x	x	x	x	x	x
1 9	1 7 6 8 4 8	THREAD TAKE-UP SPRING CASE, BACK	x	x	x	x	x	x	x	x	x	x
2 0	1 7 6 8 4 9	THREAD TAKE-UP SPRING	x	x	x	x	x	x	x	x	x	x
2 1	1 7 6 8 5 0	THREAD TAKE-UP SPRING COVER	x	x	x	x	x	x	x	x	x	x
2 2	1 7 6 7 2 2	THREAD GIARD BRACKET MOUNTING SCREW (4)	x	x	x	x	x	x	x	x	x	x
2 3	1 7 6 8 5 1	THREAD GIARD (LOWER)	x	x	x	x	x	x	x	x	x	x
2 4	1 7 6 7 2 2	THREAD GIARD MOUNTING SCREW (LOWER)	x	x	x	x	x	x	x	x	x	x

TENSION MECHANISM

REF.	SINGER PART #	TENSION MECHANISM	3 3 3 3 3					3 3 3 3 3				
			0	0	0	0	0	0	0	0	0	0
			1	2	3	4	5	1	2	3	4	5
1	1 7 7 3 3 1	THREAD GUARD ASSEMBLY (3001/3011)	X						X			
1	1 7 7 3 3 2	THREAD GUARD ASSEMBLY (3002/3012)		X						X		
1	1 7 7 3 3 3	THREAD GUARD ASSEMBLY (3003/3013)			X						X	
1	1 7 7 3 3 4	THREAD GUARD ASSEMBLY (3004/3014)				X						X
1	1 7 7 3 3 5	THREAD GUARD ASSEMBLY (3005/3015)					X					X
2	1 7 6 8 2 5	THREAD GUIDE MOUNTING SCREW (UPPER)	X	X	X	X	X	X	X	X	X	X
3	1 7 6 8 2 5	THREAD GUIDE ASSEMBLY (UPPER)	X	X	X	X	X	X	X	X	X	X
4	1 7 7 3 3 5	THREAD GUARD BRACKET	X	X	X	X	X	X	X	X	X	X
6	1 7 6 8 2 8	TENSION DISC	X	X	X	X	X	X	X	X	X	X
6	1 7 6 8 2 9	TENSION DISC	X	X	X	X	X	X	X	X	X	X
7	1 7 6 8 3 0	TENSION RELEASE LEVER	X	X	X	X	X	X	X	X	X	X
8	1 7 6 8 3 1	TENSION SPRING (SMALL)	X	X	X	X	X	X	X	X	X	X
9	1 7 6 8 3 2	TENSION SPRING (LARGE)	X	X	X	X	X	X	X	X	X	X
10	1 7 7 3 3 7	TENSION CONTROL KNOB ASSEMBLY (3001/3011)	X						X			
10	1 7 7 3 3 8	TENSION CONTROL KNOB ASSEMBLY (3002/3012)		X						X		
10	1 7 7 3 3 9	TENSION CONTROL KNOB ASSEMBLY (3003/3013)			X						X	
10	1 7 7 3 4 0	TENSION CONTROL KNOB ASSEMBLY (3004/3014)				X						X
10	1 7 7 3 4 1	TENSION CONTROL KNOB ASSEMBLY (3005/3015)					X					X
11	1 7 6 8 3 7	TENSION CONTROL RING	X	X	X	X	X	X	X	X	X	X
12	1 7 7 3 4 2	TENSION CONTROL KNOB (3001/3011)	X						X			
12	1 7 7 3 4 3	TENSION CONTROL KNOB (3002/3012)		X						X		
12	1 7 7 3 4 4	TENSION CONTROL KNOB (3003/3013)			X						X	
12	1 7 7 3 4 5	TENSION CONTROL KNOB (3004/3014)				X						X
12	1 7 7 3 4 6	TENSION CONTROL KNOB (3005/3015)					X					X
13	1 7 6 8 4 2	TENSION CONTROL KNOB STOPPER	X	X	X	X	X	X	X	X	X	X
14	1 7 6 8 4 3	CONTROL KNOB WASHER	X	X	X	X	X	X	X	X	X	X
15	1 7 6 8 4 4	CONTROL KNOB NUT (2)	X	X	X	X	X	X	X	X	X	X
16	1 7 6 8 4 5	TENSION STUD SCREW	X	X	X	X	X	X	X	X	X	X
17	1 7 6 8 4 6	SPRING WASHER	X	X	X	X	X	X	X	X	X	X
18	1 7 6 8 4 7	THREAD TAKE-UP SPRING CASE, FRONT	X	X	X	X	X	X	X	X	X	X
19	1 7 6 8 4 8	THREAD TAKE-UP SPRING CASE, BACK	X	X	X	X	X	X	X	X	X	X
20	1 7 6 8 4 9	THREAD TAKE-UP SPRING	X	X	X	X	X	X	X	X	X	X
21	1 7 6 8 5 0	THREAD TAKE-UP SPRING COVER	X	X	X	X	X	X	X	X	X	X
22	1 7 6 7 2 2	THREAD GIARD BRACKET MOUNTING SCREW (4)	X	X	X	X	X	X	X	X	X	X
23	1 7 6 8 5 1	THREAD GIARD (LOWER)	X	X	X	X	X	X	X	X	X	X
24	1 7 6 7 2 2	THREAD GIARD MOUNTING SCREW (LOWER)	X	X	X	X	X	X	X	X	X	X

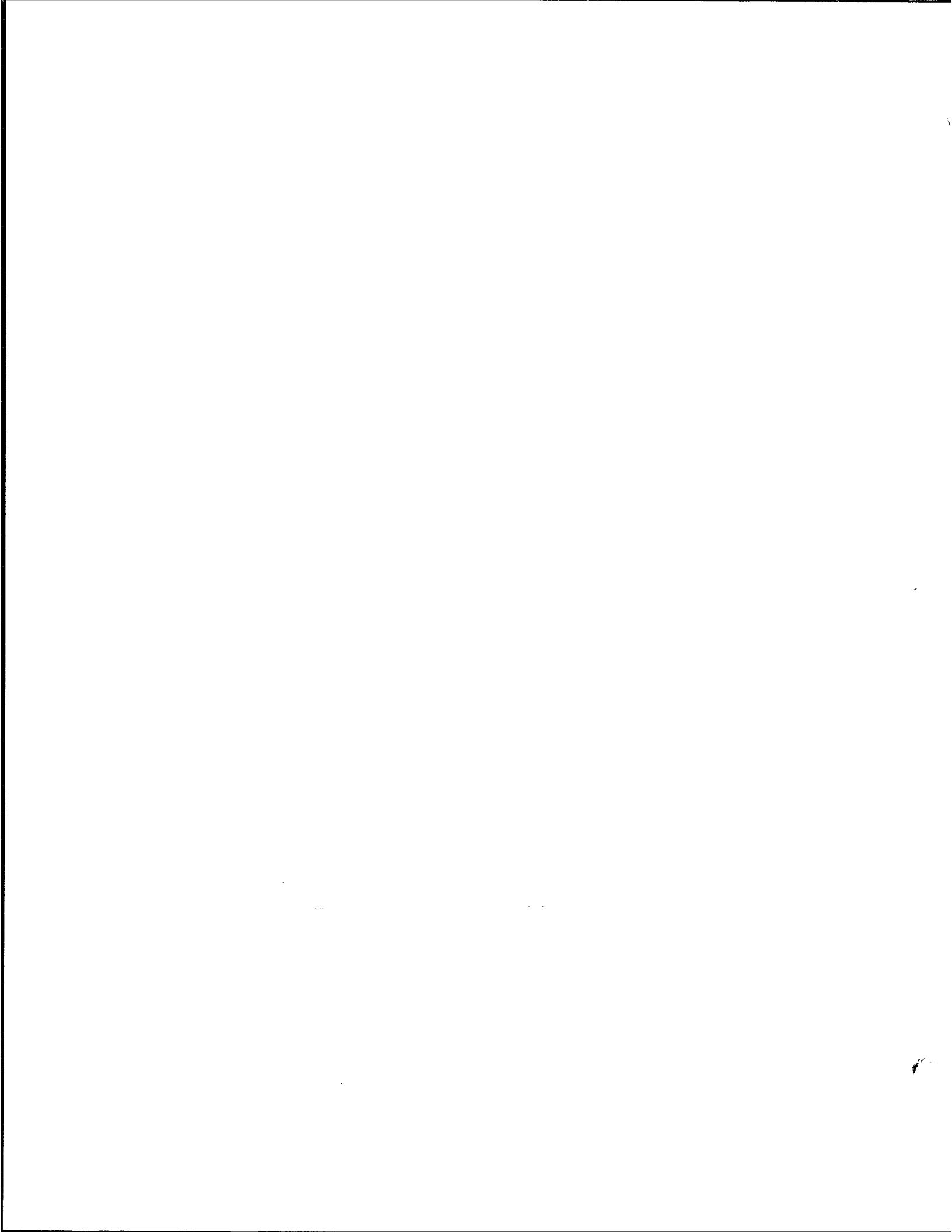

TENSION MECHANISM

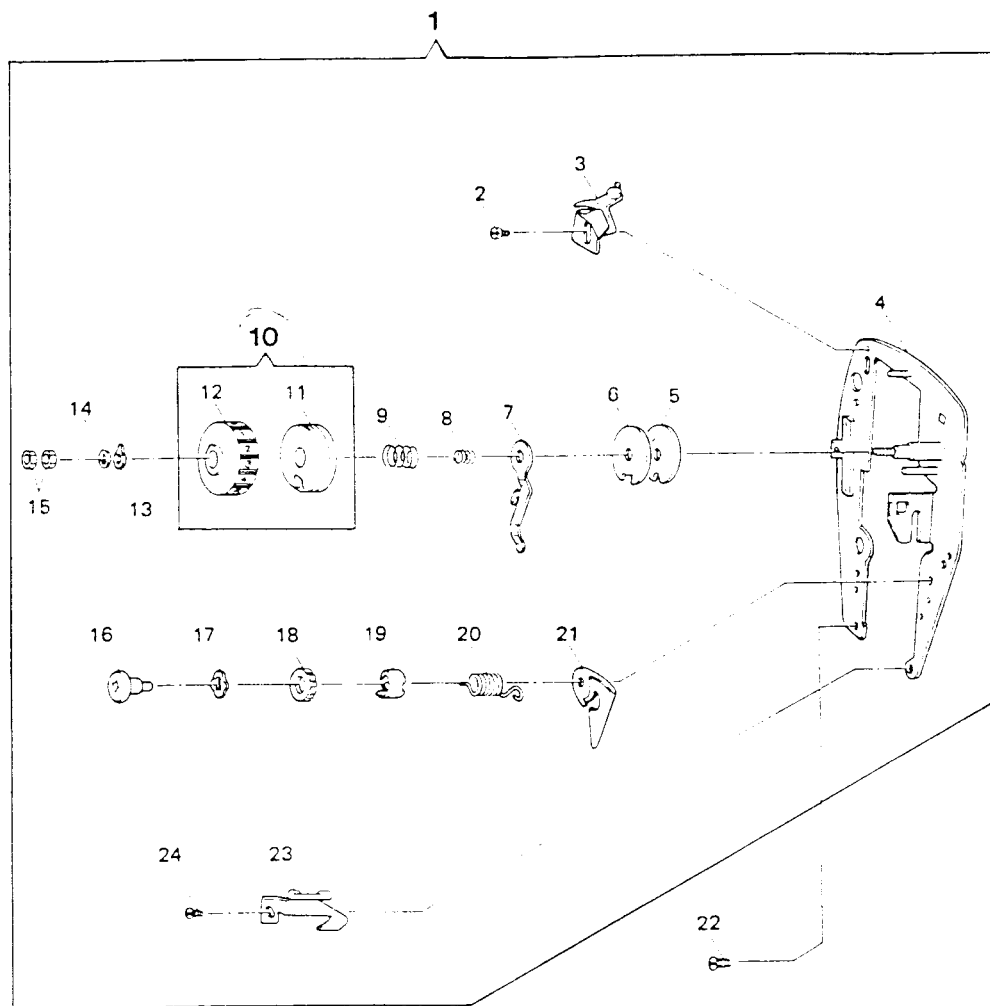

HEAD END MODULE

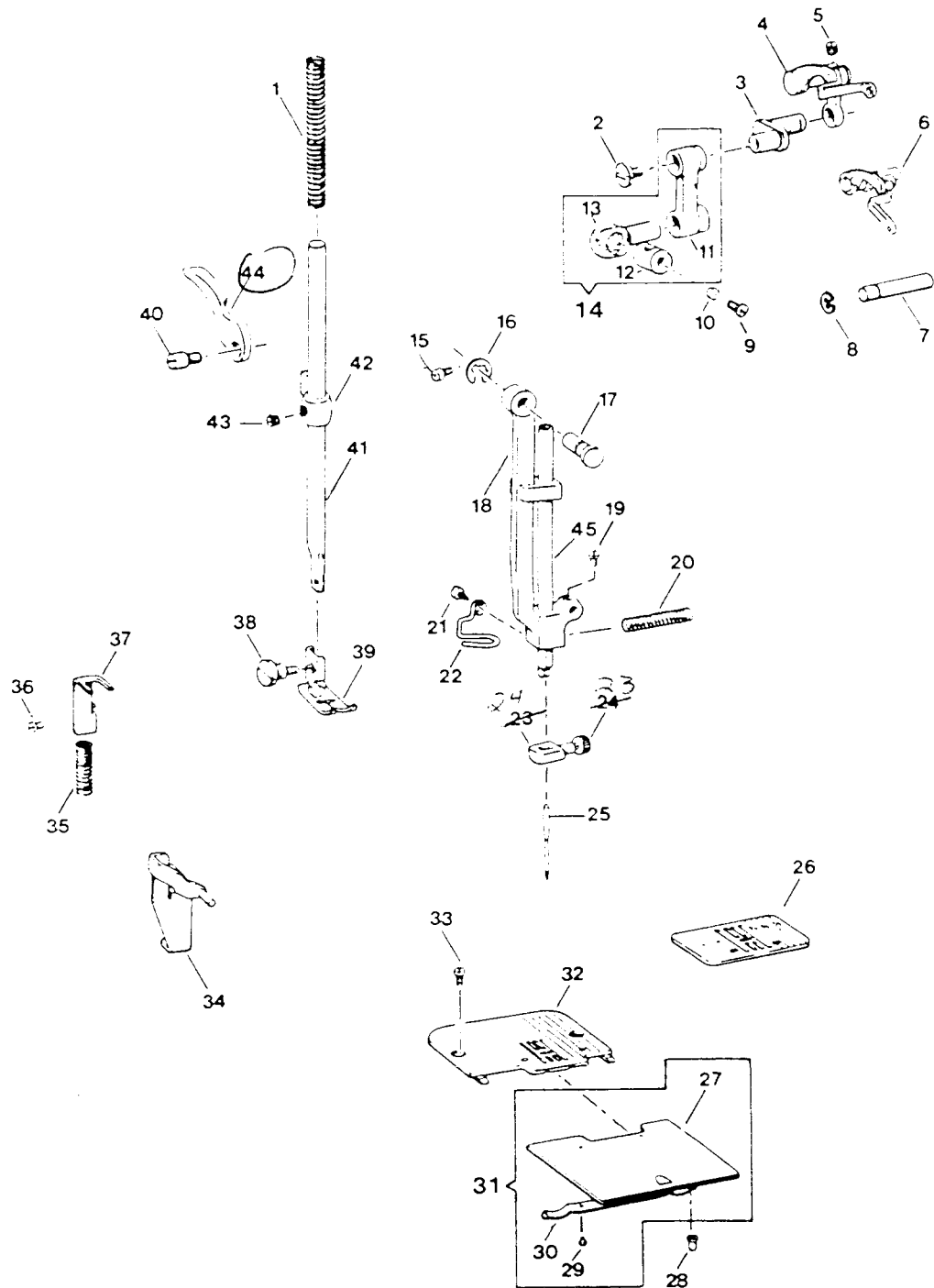

HEAD END MODULE

REF.	SINGER PART #	HEAD END MODULE	3 3 3 3 3					3 3 3 3 3					
			0 0 0 0 0					0 0 0 0 0					
			0 0 0 0 0					1 1 1 1 1					
			1	2	3	4	5	1	2	3	4	5	
1	1 7 6 8 5 2	PRESSER BAR SPRING	x	x	x	x	x	x	x	x	x	x	x
2	1 7 6 8 5 3	NEEDLE BAR CRANK SET SCREW	x	x	x	x	x	x	x	x	x	x	x
3	1 7 6 8 5 4	NEEDLE BAR CRANK	x	x	x	x	x	x	x	x	x	x	x
4	1 7 6 8 5 5	THREAD TAKE-UP LEVER ASSEMBLY	x	x	x	x	x	x	x	x	x	x	x
5	1 7 6 7 6 6	THREAD TAKE-UP LEVER SET SCREW	x	x	x	x	x	x	x	x	x	x	x
6	1 7 6 8 5 6	THREAD TAKE-UP LEVER	x	x	x	x	x	x	x	x	x	x	x
7	1 7 6 8 5 7	SHAFT	x	x	x	x	x	x	x	x	x	x	x
8	1 7 6 8 5 8	RETAINING RING	x	x	x	x	x	x	x	x	x	x	x
9	1 7 6 8 5 9	NEEDLE BAR CRAMP SET SCREW	x	x	x	x	x	x	x	x	x	x	x
10	1 7 6 8 6 0	METAL PLATE	x	x	x	x	x	x	x	x	x	x	x
11	1 7 6 8 6 1	NEEDLE BAR CRANK ROD	x	x	x	x	x	x	x	x	x	x	x
12	1 7 6 8 6 2	NEEDLE BAR CLAMP	x	x	x	x	x	x	x	x	x	x	x
13	1 7 6 8 6 3	NEEDLE BAR CLAMP STUD	x	x	x	x	x	x	x	x	x	x	x
14	1 7 6 8 6 4	NEEDLE BAR CRANK ROD ASSEMBLY	x	x	x	x	x	x	x	x	x	x	x
15	1 7 7 7 2 5	NEEDLE BAR CLAMP SET SCREW	x	x	x	x	x	x	x	x	x	x	x
16	1 7 6 6 8 9	RETAINING RING	x	x	x	x	x	x	x	x	x	x	x
17	1 7 8 8 6 5	NEEDLE BAR SUPPORTER STUD	x	x	x	x	x	x	x	x	x	x	x
18	1 7 8 8 6 6	NEEDLE BAR SUPPORTER	x	x	x	x	x	x	x	x	x	x	x
19	1 7 8 8 6 7	STUD SET SCREW	x	x	x	x	x	x	x	x	x	x	x
20	1 7 8 8 6 8	SPRING	x	x	x	x	x	x	x	x	x	x	x
21	1 7 8 8 6 9	THREAD GUIDE MOUNTING SCREW	x	x	x	x	x	x	x	x	x	x	x
22	1 7 8 8 7 0	NEEDLE BARTHREAD GUIDE	x	x	x	x	x	x	x	x	x	x	x
23	1 7 8 8 7 1	NEEDLE CLAMP SCREW ✓	x	x	x	x	x	x	x	x	x	x	x
24	1 7 8 8 7 2	NEEDLE CLAMP ✓	x	x	x	x	x	x	x	x	x	x	x
25	1 7 8 8 7 3	NEEDLE. NO. 14 (2045)	x	x	x	x	x	x	x	x	x	x	x
26	1 7 6 8 7 4	NEEDLE PLATE ASSEMBLY (FREE ARM)									x	x	x
27	1 7 6 8 7 5	SLIDE PLYTE	x	x	x	x	x	x	x	x			
28	1 7 6 8 7 6	VINYL PLATE	x	x	x	x	x	x	x	x			
29	1 7 6 8 7 7	SLIDE PLATE SPRING SCREW	x	x	x	x	x	x	x	x			
30	1 7 6 8 7 8	SLIDE PLATE SPRING	x	x	x	x	x	x	x	x			
31	1 7 6 8 7 9	SLIDE PLATE ASSEMBLY	x	x	x	x	x	x	x	x			
32	1 7 6 8 8 0	NEEDLE PLATE (FLAT BED)	x	x	x	x	x	x	x	x			
33	1 7 6 8 8 1	NEEDLE PLATE MONTING SCREW (2)	x	x	x	x	x	x	x	x			
34	1 7 6 8 8 2	TENSION RELEASER. A	x	x	x	x	x	x	x	x	x	x	x
35	1 7 6 8 8 3	SPRING	x	x	x	x	x	x	x	x	x	x	x
36	1 7 6 7 2 2	SPRING BRACKET MOUNTING SCREW	x	x	x	x	x	x	x	x	x	x	x
37	1 7 6 8 8 4	TENSION RELEASE SPRING BRACKET	x	x	x	x	x	x	x	x	x	x	x
38	1 7 6 8 8 5	THUMB SCREW	x	x	x	x	x	x	x	x	x	x	x
39	1 7 6 8 8 6	PRESSER FOOT ASSEMBLY	x	x	x	x	x	x	x	x	x	x	x
40	1 7 6 8 8 7	PRESSER FOOT LIFTER STUD SCREW	x	x	x	x	x	x	x	x	x	x	x
41	1 7 6 8 8 8	PRESSER BAR	x	x	x	x	x	x	x	x	x	x	x
42	1 7 6 8 8 9	PRESSER BAR GUIDE BFACKET	x	x	x	x	x	x	x	x	x	x	x
43	1 7 6 8 9 0	PRESSER BAR GUIDE BFACKET SET SCREW	x	x	x	x	x	x	x	x	x	x	x
44	<u>1 7 7 3 4 7</u>	PRESSER FOOT LIFTER	x	x	x	x	x	x	x	x	x	x	x
45	1 7 1 8 5 4	NEEDLE BAR	x	x	x	x	x	x	x	x	x	x	x

71596

FEED MECHANISM (A)

REF.	SINGER PART #	FEED MECHANISM (A)	3 3 3 3 3					3 3 3 3 3				
			0	0	0	0	0	0	0	0	0	0
			1	2	3	4	5	1	2	3	4	5
1	1 7 6 8 9 2	LOWER SHAFT BEVEL GEAR						x	x	x	x	x
2	1 7 6 7 9 6	LOWER SHAFT BEVEL GEAR	x	x	x	x	x					
2	1 7 6 7 6 3	LOWER SHAFT BEVEL GEAR SET SCREW. SMALL	x	x	x	x	x	x	x	x	x	x
3	1 7 6 8 9 3	LOWER SHAFT BEVEL GEAR SET SCREW. LARGE	x	x	x	x	x	x	x	x	x	x
4	1 7 6 8 9 4	LOWER SHAFT BUSHING. LEFT. WASHER						x	x	x	x	x
5	1 7 6 7 6 6	LOWER SHAFT BUSHING. LEFT. SET SCREW	x	x	x	x	x	x	x	x	x	x
6	1 7 6 8 9 5	LOWER SHAFT BUSHING. LEFT	x	x	x	x	x	x	x	x	x	x
7	1 7 6 8 9 6	LOWER SHAFT	x	x	x	x	x					
8	1 7 6 8 9 7	VERTICAL FEED CAN	x	x	x	x	x					
9	1 7 6 8 0 0	VERTICAL FEED CAN SET SCREW	x	x	x	x	x					
10	1 7 6 8 9 8	LOWER SHAFT CRANK	x	x	x	x	x					
11	1 7 6 8 9 9	LOWER SHAFT CRANK ASSEMBLY	x	x	x	x	x					
12	1 7 6 9 0 0	LOWER SHAFT CRANK SCREW	x	x	x	x	x	x	x	x	x	x
13	1 7 6 9 0 1	LOWER SHAFT CRANK HINGE SHAFT SCREW	x	x	x	x	x	x	x	x	x	x
14	1 7 6 9 0 2	LOWER SHAFT BUSHING. RIGHT	x	x	x	x	x	x	x	x	x	x
15	1 7 6 9 0 3	VERTICAL FEED SHAFT SET SCREW	x	x	x	x	x					
16	1 7 6 9 0 4	SPRING WASHER	x	x	x	x	x					
17	1 7 6 9 0 5	WASHER	x	x	x	x	x					
18	1 7 6 9 0 6	VERTICAL FEED LEVER	x	x	x	x	x					
19	1 7 6 6 8 9	VERTICAL FEED SHAFT RETAINING RING (2)	x	x	x	x	x	x	x	x	x	x
20	1 7 6 9 0 7	VERTICAL FEED SHAFT ASSEMBLY	x	x	x	x	x					
21	1 7 6 9 0 8	VERTICAL FEED CRANK ROLLER	x	x	x	x	x					
22	1 7 6 9 0 9	RING	x	x	x	x	x					
23	1 7 6 9 1 0	FEED DOG	x	x	x	x	x					
24	1 7 6 9 1 1	FEED BAR	x	x	x	x	x					
25	1 7 6 9 1 3	FEED DOG SET SCREW (2)	x	x	x	x	x	x	x	x	x	x
26	1 7 6 9 1 4	ROCK SHAFT SPRING	x	x	x	x	x					
27	1 7 6 9 1 5	FEED ROCK SHAFT CENTER SCREW NUT (2)	x	x	x	x	x					
28	1 7 6 9 1 6	FEED ROCK SHAFT CENTER SCREW (2)	x	x	x	x	x					
29	1 7 6 9 1 7	FELT (2)	x	x	x	x	x					
30	1 7 6 9 0 1	FEED BAR HINGE SHAFT SET SCREW	x	x	x	x	x	x	x	x	x	x
31	1 7 6 9 1 8	HORIZONTAL FEED ROCKING SHAFT	x	x	x	x	x					
31	1 7 6 9 1 9	HORIZONTAL FEED ROCKING SHAFT						x	x	x	x	x
32	1 7 6 9 2 0	FEED BAR SHAFT	x	x	x	x	x					
33	1 7 6 9 0 9	FEED BAR HINGE SHAFT RETAINING RING	x	x	x	x	x	x	x	x	x	x
34	1 7 6 9 2 1	HORIZONTAL FEED SHAFT ARM SET SCREW. SMALL	x	x	x	x	x	x	x	x	x	x
35	1 7 6 9 0 0	HORIZONTAL FEED SHAFT ARM SET SCREW. LARGE	x	x	x	x	x	x	x	x	x	x
36	1 7 6 9 2 2	HORIZONTAL FEED SHAFT ARM	x	x	x	x	x					
37	1 7 6 9 2 3	HORIZONTAL FEED ROCKING SHAFT ASSMBLY						x	x	x	x	
37	1 7 6 9 2 4	HORIZONTAL FEED ROCKING SHAFT ASSMBLY						x				
38	1 7 6 9 2 5	HORIZONTAL FEED SHFT ARM ASSEMBLY	x	x	x	x	x					

FEED MECHANISM (A)

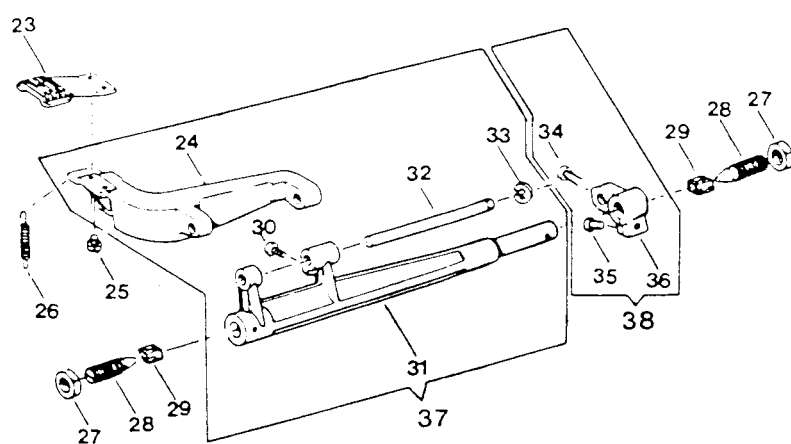
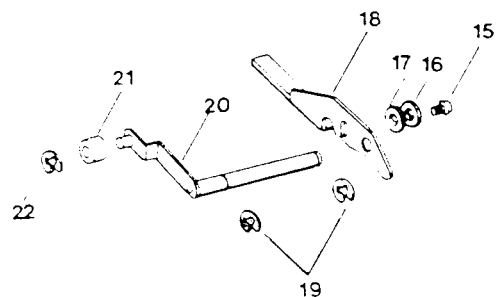
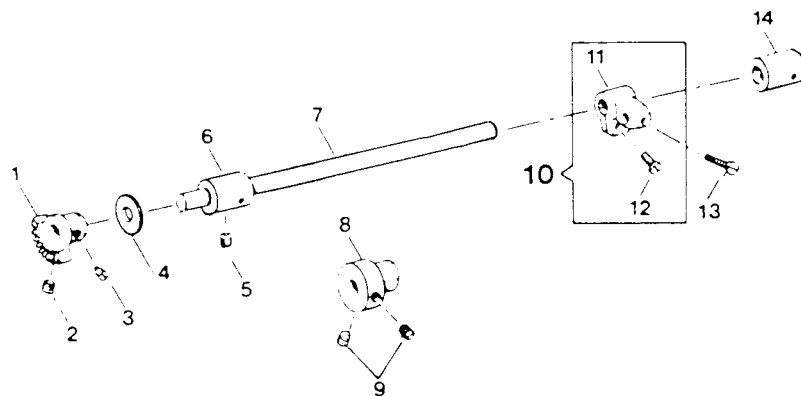

FEED MECHANISM (B)

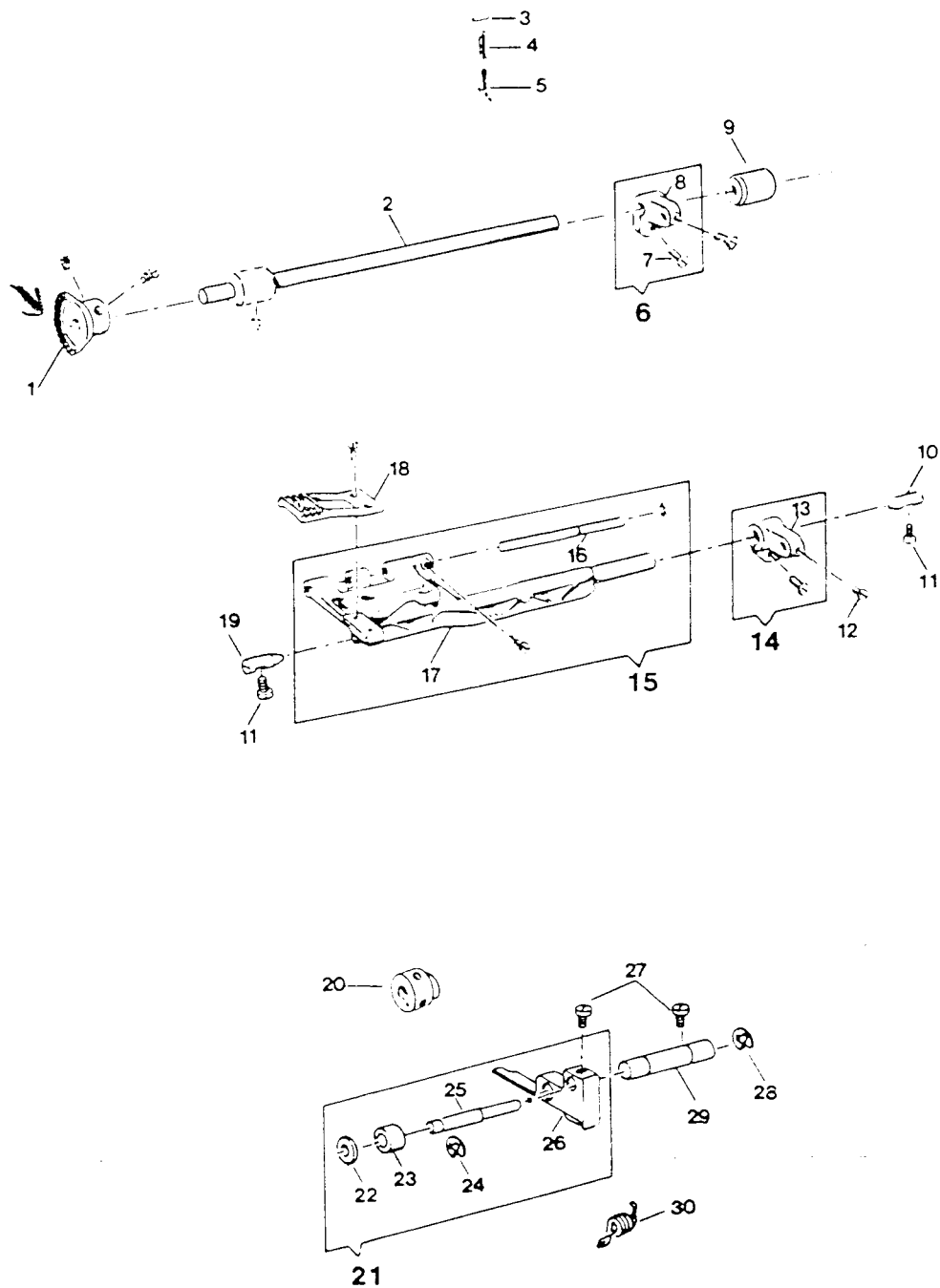

FEED MECHANISM (B)

REF.	SINGER PART #	FEED MECHANISM (B)	3 3 3 3 3	3 3 3 3 3
			0 0 0 0 0	0 0 0 0 0
			0 0 0 0 0	1 1 1 1 1
			<u>1 2 3 4 5</u>	<u>1 2 3 4 5</u>
1	1 7 6 9 2 6	LOWER SHAFT BEVEL GEAR		x x x x x
2	1 7 6 9 2 7	LOWER SHAFT		x x x x x
3	1 7 6 7 7 0	SPRING RETAINING PIN		x x x x x
4	1 7 6 9 2 8	SPRING		x x x x x
5	1 7 6 9 2 9	SPRING HANGER		x x x x x
6	1 7 6 9 3 0	LOWER SHAFT CRANK ASSEMBLY		x x x x x
7	1 7 6 9 0 0	LOWER SHAFT CRANK SCREW		x x x x x
8	1 7 6 9 3 1	LOWER SHAFT CRANK		x x x x x
9	1 7 6 9 3 2	LOWER SHAFT BUSHING. RIGHT		x x x x x
10	1 7 6 9 3 3	FEED ROCK SHAFT CENTER. RIGHT		x x x x x
11	1 7 6 9 0 1	FEED ROCK SHAFT CENTER SET SCREW (2)		x x x x x
12	1 7 6 9 0 1	HORIZONTAL FEED SHAFT ARM SET SCREW. SMALL		x x x x x
13	1 7 6 9 3 4	HORIZONTAL FEED SHAFT ARM		x x x x x
14	1 7 6 9 3 5	HORIZONTAL FEED SHAFT ARM ASSEMBLY		x x x x x
15	1 7 6 9 3 6	HORIZONTAL FEED ROCKING SHAFT ASSBMLY		x x x x x
16	1 7 6 9 3 7	FEED BAR HINGE SHAFT		x x x x x
17	1 7 6 9 3 8	FEED BAR		x x x x x
18	1 7 6 9 3 9	FEED DOG		x x x x x
19	1 7 6 9 4 0	FEED ROCK SHAFT CENTER. LEFT		x x x x x
20	1 7 6 9 4 1	VERTICAL FEED CAN		x x x x x
21	1 7 6 9 4 2	FEED LEVER ASSEMBLY		x x x x x
22	1 7 6 9 4 3	VERTICAL FEED SHAFT WASHER		x x x x x
23	1 7 6 9 4 4	VERTICAL FEED SHAFT COLLAR		x x x x x
24	1 7 6 9 4 5	RETAINING RING		x x x x x
25	1 7 6 9 4 6	VERTICAL FEED SHAFT		x x x x x
26	1 7 6 9 4 7	VERTICAL FEED LEVER		x x x x x
27	1 7 6 9 0 1	VERTICAL FEED LEVER SCREW (2)		x x x x x
28	1 7 6 6 8 9	RETAINING RING		x x x x x
29	1 7 6 9 4 8	FEED LEVER ASSEMBLY SHAFT		x x x x x
30	1 7 6 9 4 9	FEED LEVER SPRING		x x x x x

FEED MECHANISM (C)

REF.	SINGER PART #	FEED MECHANISM (C)	3 3 3 3 3					3 3 3 3 3				
			0	0	0	0	0	0	0	0	0	0
			1	2	3	4	5	1	2	3	4	5
1	1 7 6 9 5 0	FORKED CONNECTING ROD WASHER	x	x	x	x	x	x	x	x	x	x
2	1 7 6 9 5 1	SLIDE BLOCK STUD	x	x	x	x	x	x	x	x	x	x
3	1 7 6 9 5 2	FORKED CONNECTING ROD						x	x	x	x	x
4	1 7 6 9 5 3	SLIDE BLOCK	x	x	x	x	x	x	x	x	x	x
5	1 7 6 9 5 4	SLIDE BLOCK ASSEMBLY	x	x	x	x	x	x	x	x	x	x
6	1 7 6 9 5 5	CRANK ROD STUD	x	x	x	x	x	x	x	x	x	x
7	1 7 6 6 8 9	CRANK ROD STUD RETAINING RING	x	x	x	x	x	x	x	x	x	x
8	1 7 6 9 5 6	FORKED CONNECTING ROD	x	x	x	x	x					
9	1 7 6 9 5 7	CRANK ROD WASHER (2)	x	x	x	x	x	x	x	x	x	x
10	1 7 6 9 5 8	CRANK ROD SET SCREW (2)	x	x	x	x	x	x	x	x	x	x
11	1 7 6 9 5 9	CRANK ROD						x	x	x	x	x
12	1 7 6 9 6 1	CRANK ROD	x	x	x	x	x					
13	1 7 6 9 6 0	CRANK ROD ASSEMBLY	x	x	x	x	x					
14	1 7 6 9 6 2	CRANK ROD ASSEMBLY						x	x	x	x	x
15	1 7 6 9 6 3	LEVER ADJUSTING SCREW	x	x	x	x		x	x	x	x	
16	1 7 6 9 6 4	FEED REGULATION LEVER SPRING		x	x	x		x	x	x		
16	1 7 6 9 6 5	FEED REGULATION LEVER SPRING. A	x					x				
17	1 7 6 9 6 6	FEED REGULATION LEVER	x	x	x	x		x	x	x	x	
17	1 7 6 9 6 7	Z SELECTING LEVER		x	x	x		x	x	x		
18	1 7 6 9 6 8	LEVER ADJUSTING SCREW NUT		x	x	x		x	x	x		
19	1 7 6 9 6 9	FEED REGULATION LEVER STUD SCREW		x	x	x		x	x	x		
20	1 7 6 9 7 0	FEED REGULATION LEVER SPRING. B	x					x				
21	1 7 6 9 0 9	RELEASE LEVER SHAFT RITAINING RING (3)	x	x	x	x		x	x	x	x	
22	1 7 6 7 2 7	SPRING	x	x	x	x	x	x	x	x	x	x
23	1 7 6 7 2 5	RELEASE LEVER SHAFT SET SCREW	x	x	x	x	x	x	x	x	x	x
24	1 7 6 9 7 1	RELEASE LEVER	x	x	x	x		x	x	x	x	
25	1 7 6 9 7 2	RELEASE LEVER SHAFT	x	x	x	x		x	x	x	x	
26	1 7 6 7 2 6	RELEASE LEVER SHAFT	x					x				

FEED MECHANISM (C)

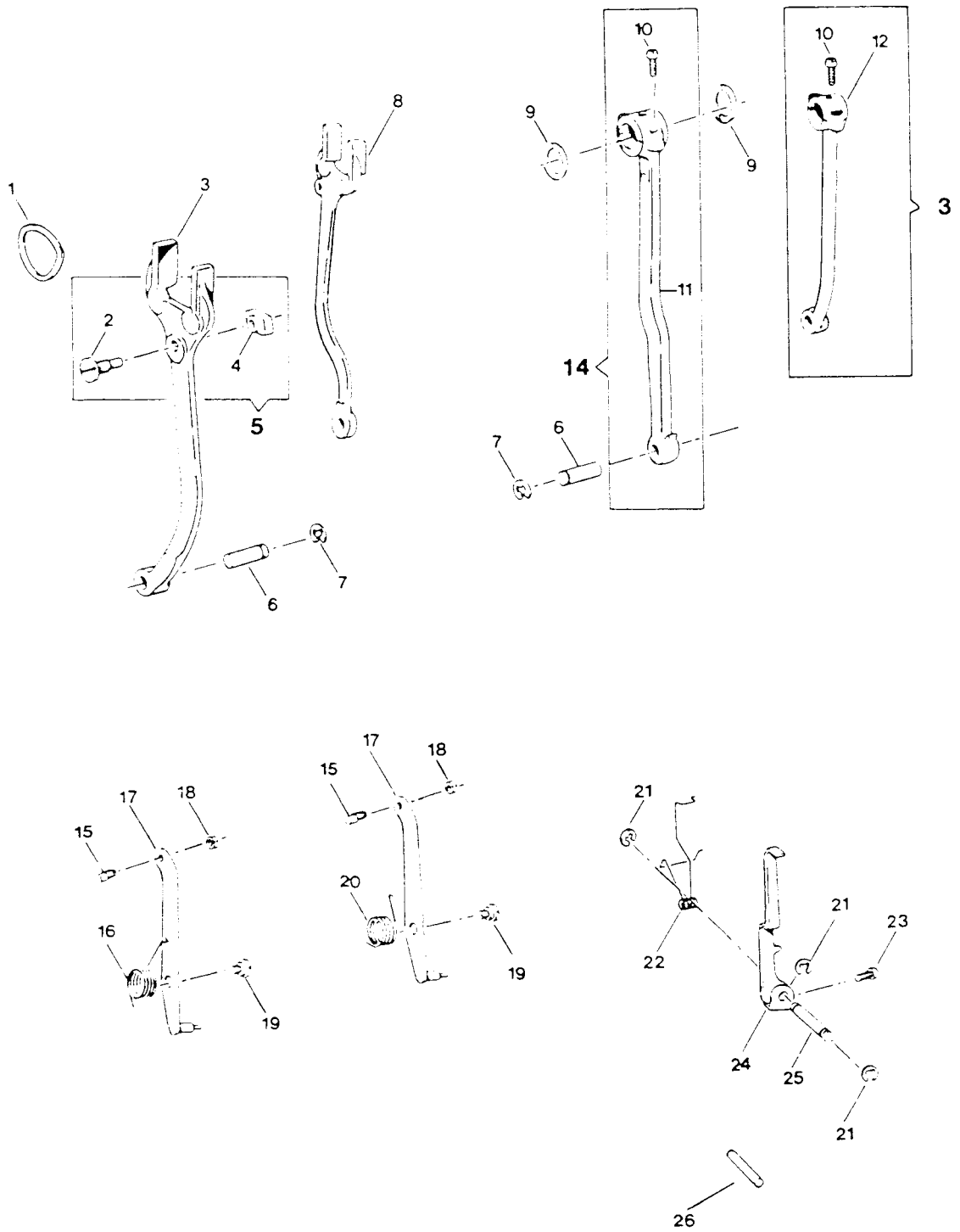

FEED MECHANISM (D)

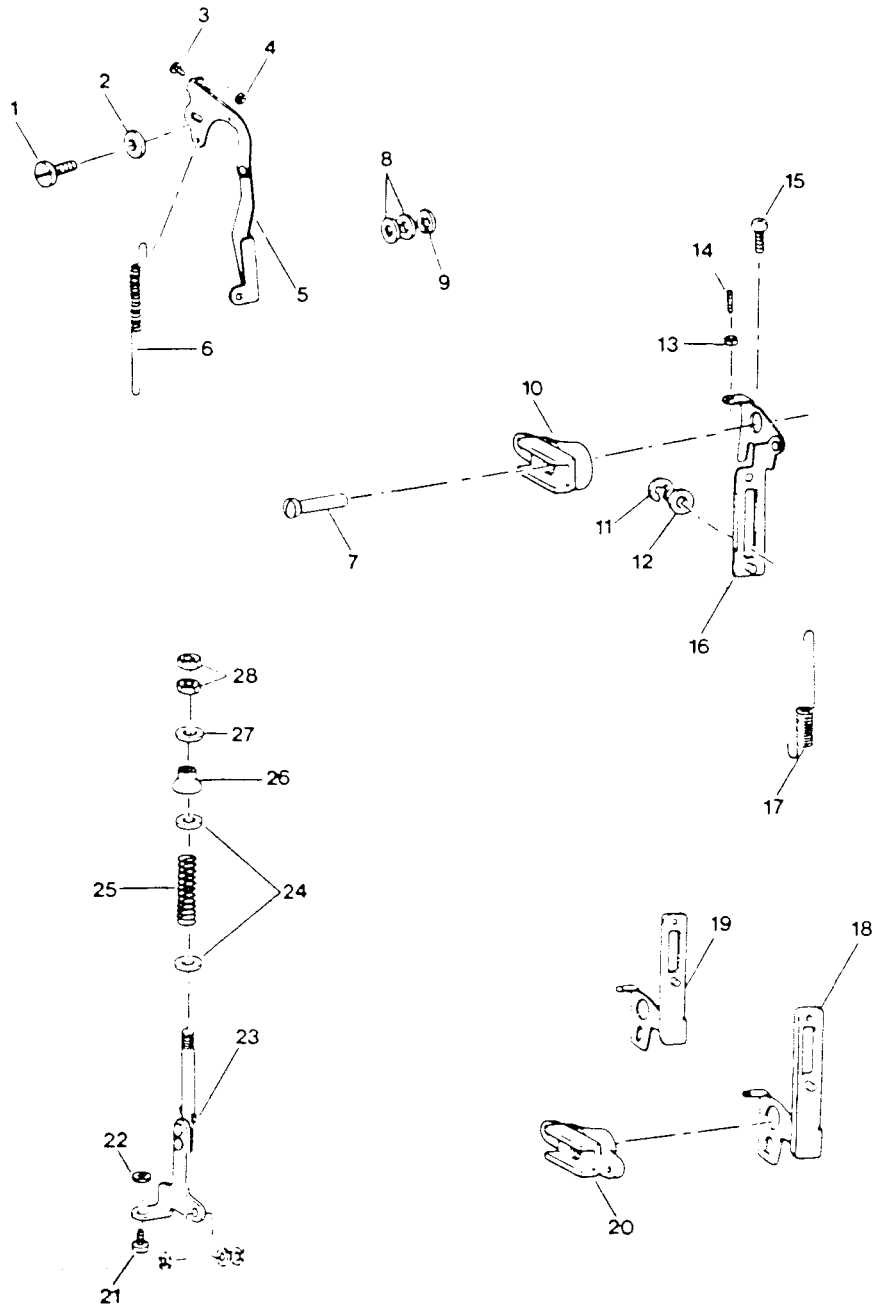

FEED MECHANISM (D)

REF.	SINGER PART #	FEED MECHANISM (D)	3 3 3 3 3					3 3 3 3 3				
			0	0	0	0	0	0	0	0	0	0
			1	2	3	4	5	1	2	3	4	5
1	1 7 6 9 7 3	FEED LEVER MOUNTING SCREW				x						x
2	1 7 6 9 7 4	FEED LEVER MOUNTING SCREW WASHER				x						x
3	1 7 6 9 7 5	FEED LEVER SCREW				x						x
4	1 7 6 9 7 6	FEED LEVER SCREW NUT				x						x
5	1 7 6 9 7 7	FEED LEVER ASSEMBLY				x						x
6	1 7 6 9 7 8	FEED LEVER SPRING				x						x
7	1 7 6 9 7 9	FEED REGULATOR STUD	x	x	x	x	x		x	x	x	x
8	1 7 6 9 8 0	FEED REGULATING BAR WASHER (2)	x	x	x	x			x	x	x	x
9	1 7 6 9 4 5	FEED REGULATING BAR RETAINING RING	x	x	x	x			x	x	x	x
10	1 7 6 9 8 1	FEED REGULATOR							x		x	x
10	1 7 6 9 8 2	FEED REGULATOR										x
11	1 7 6 6 8 9	FEED REGULATING ADJG. PLATE MTG. RING										x
12	1 7 6 6 9 1	FEED REGULATING ADJG. PLATE MTG. WASHER				x						x
13	1 7 6 9 8 3	FEED REGULATOR ADJG. PLATE ADJG. SCREW NUT	x	x	x	x	x		x	x	x	x
14	1 7 6 9 8 4	FEED REGULATOR ADJG. PLATE ADJG. SCREW	x	x	x	x	x		x	x	x	x
15	1 7 6 9 5 8	FEED REGULATOR ADJUSTING PLATE MTG. SCREW	x	x	x	x	x		x	x	x	x
16	1 7 6 9 8 5	FEED REGULATOR ADJG. PLATE				x						x
17	1 7 6 9 8 6	SPRING	x		x	x	x		x		x	x
18	1 7 6 9 8 7	FEED REGULATOR ADJG. PLATE				x	x					x
19	1 7 6 9 8 8	FEED REGULATOR ADJUSTING PLATE	x									x
20	1 7 6 9 8 9	FEED REGULATOR				x						
20	1 7 6 9 9 0	FEED REGULATOR	x			x	x	x				
21	1 7 6 9 7 5	FEED REGULATING BAR ASSEMBLY MTG. SCREW	x	x	x	x			x	x	x	x
22	1 7 6 9 7 6	FEED REGULATING BAR ASSEMBLY MTG. SCREWNUT	x	x	x	x			x	x	x	x
23	1 7 6 9 9 1	FEED REGULATING BAR ASSEMBLY				x	x	x				x
24	1 7 6 9 9 2	FEED REGULATING BAR ROD WASHER (2)				x	x	x				x
25	1 7 6 9 9 3	FEED REGULATING BAR ROD SPRING				x	x	x				x
26	1 7 6 9 9 4	FEED REGULATING BAR ROD COLLAR				x	x	x				x
27	1 7 6 9 9 5	FEED REGULATING BAR ROD NUT WASHER				x	x	x				x
28	1 7 6 9 5 8	FEED REGULATING BAR ROD NUT (2) 177384				x	x	x				x

CAM MECHANISM (A)

REF.	SINGER PART #	CAM MECHANISM (A)	3 3 3 3 3	3 3 3 3 3
			0 0 0 0 0	0 0 0 0 0
			0 0 0 0 0	1 1 1 1 1
			1 2 3 4 5	1 2 3 4 5
1	1 7 6 7 2 5	SHAFT SET SCREW	x x x x	x x x x
2	1 7 6 9 9 6	FEED CAM RETAINING RING (2)	x x x x	x x x x
3	1 7 6 9 9 7	BUTTONHOLE FEED CAM	x x x	x x x
4	1 7 6 9 9 8	SPRING	x x x x	x x x x
5	1 7 6 9 9 9	SPRING	x	x
6	1 7 7 0 0 0	BUTTONHOLE FEED CONTROL CAM	x x x	x x x
7	1 7 6 9 4 5	FEED CONTROL CAM ROD RETAINING RING (2)	x x x	x x x
8	1 7 7 0 0 1	FEED CONTROL CAM ROD	x x x	x x x
9	1 7 7 0 0 2	FEED ADJG. ARM SET SCREW	x x x	x x x
1 0	1 7 7 0 0 3	FEED ADJG. ARM	x x x	x x x
1 1	1 7 7 0 0 4	PATTERN CAM ASSEMBLY	x x	x x
1 1	1 7 7 3 4 8	PATTERN CAM ASSEMBLY		x
1 2	1 7 7 0 0 5	PATTERN CAM SHAFT WASHER (LARGE)	x x x x	x x x x
1 3	1 7 7 0 0 6	PATTERN CAM SHAFT WASHER (SMALL)	x x x x	x x x x
1 4	1 7 7 0 0 7	PATTERN CAM SHAFT	x x x x	x x x x
1 5	1 7 6 7 1 7	SPRING HANGER SET SCREW	x	x
1 6	1 7 7 0 0 8	SPRING HANGER	x	x
1 7	1 7 7 0 0 9	PATTERN CAM WASHER	x	x
1 8	1 7 7 0 1 0	PATTERN CAM ASSEMBLY	x	x
1 9	1 7 6 9 7 3	Z SELECTING CAM SET SCREW	x x x	x x x
2 0	1 7 7 0 1 1	FEED SELECTING CAM	x	x
2 1	1 7 7 0 1 2	Z SELECTING CAM	x	x
2 2	1 7 6 6 8 9	Z SELECTING CAM SHAFT-RETAINING RING	x x x x	x x x x
2 3	1 7 7 0 1 3	FEED SELECTING CAM	x	x
2 3	1 7 7 0 1 4	FEED SELECTING CAM	x	x
2 3	1 7 7 3 4 9	FEED SELECTING CAM	x	x
2 4	1 7 7 0 1 5	Z SELECTING CAM	x	x
2 4	1 7 7 0 1 6	Z SELECTING CAM	x	x
2 4	1 7 7 3 5 0	Z SELECTING CAM	x	x
2 5	1 7 7 0 0 6	Z SELECTING CAM WASHER	x x x x	x x x x

CAM MECHANISM (A)

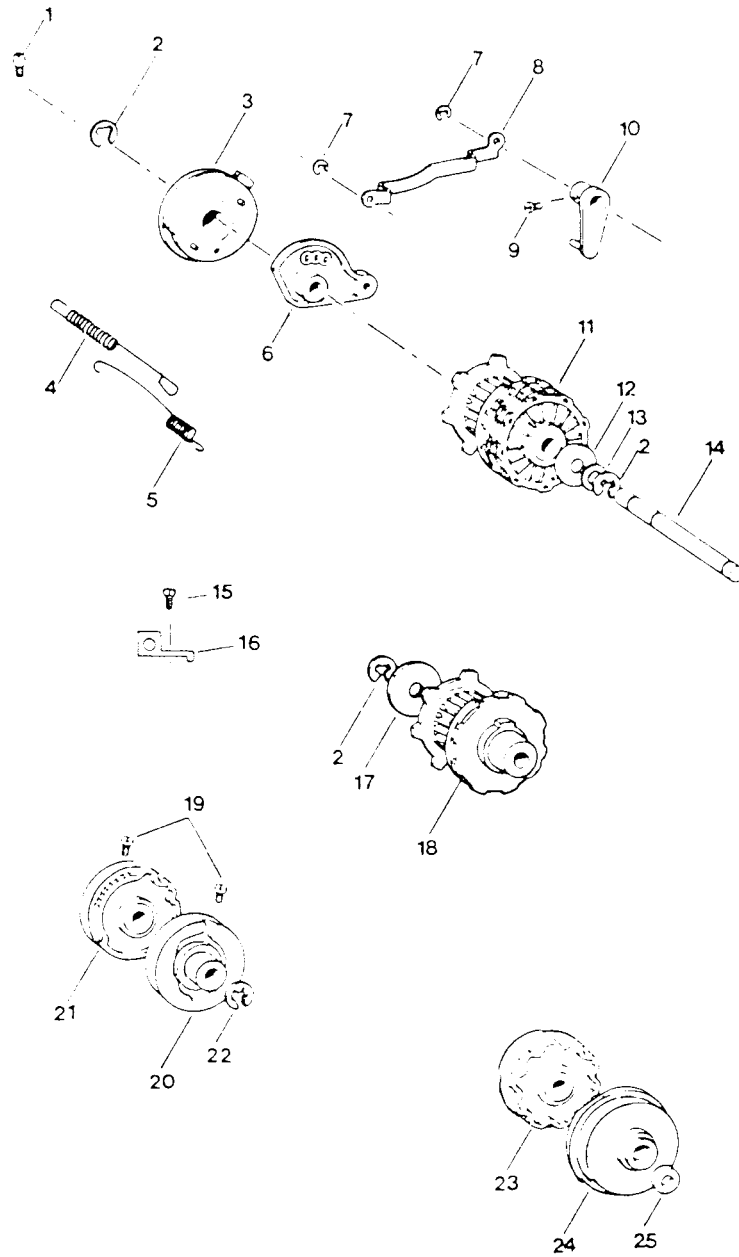

CAM MECHANISM (B)

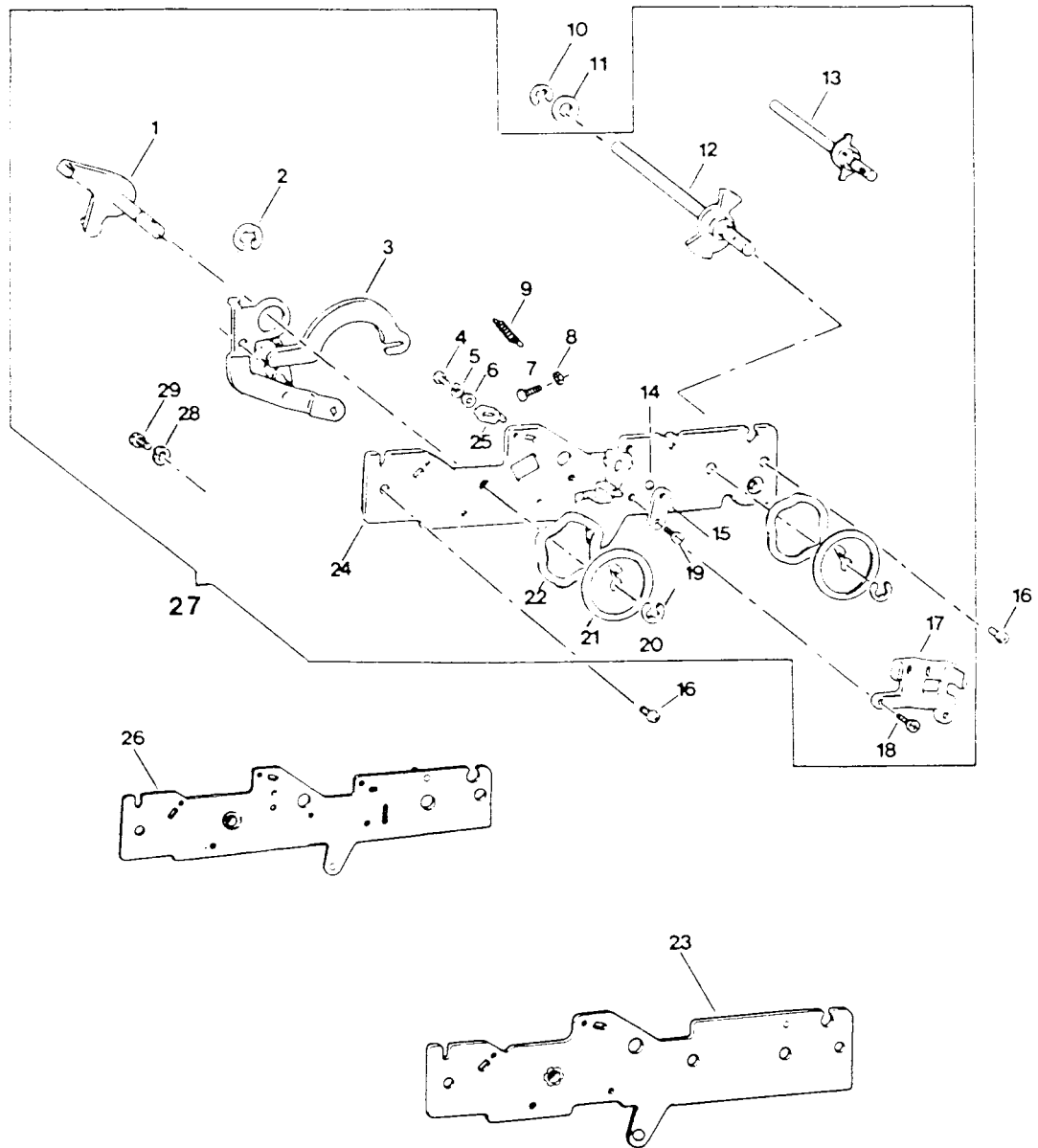

CAM MECHANISM (B)

REF.	SINGER PART #	CAM MECHANISM (B)	3 3 3 3 3					3 3 3 3 3				
			0	0	0	0	0	0	0	0	0	0
			1	2	3	4	5	1	2	3	4	5
1	1 7 7 3 5 1	ZIG-ZAG ADJUSTING LEVER	x	x	x	x	x	x	x	x	x	x
2	1 7 7 0 1 8	RETAINING RING	x	x	x	x	x	x	x	x	x	x
3	1 7 7 0 1 9	ZIG-ZAG ADJUSTING LINK ASSEMBLY	x					x				
3	1 7 7 0 2 0	ZIG-ZAG LINK ASSEMBLY			x	x	x			x	x	x
3	1 7 7 0 2 1	ZIG-ZAG LINK ASSEMBLY		x					x			
4	1 7 7 0 2 2	ZIG-ZAG WIDTH CONTROL PLATE MTG. SCREW (2)	x	x	x	x	x	x	x	x	x	x
5	1 7 7 0 2 3	ZIG-ZAG WIDTH CONTROL PLATE LOCK WASHER(2)	x	x	x	x	x	x	x	x	x	x
6	1 7 7 0 2 4	ZIG-ZAG WIDTH CONTROL PLATE WASHER (2)	x	x	x	x	x	x	x	x	x	x
7	1 7 7 0 2 5	ADJUSTING SCREW	x					x				
8	1 7 6 9 7 6	ADJUSTING SCREW NUT	x					x				
9	1 7 7 0 2 5	SPRING (177389)	x					x				
10	1 7 6 9 0 9	DIAL SHAFT RETAINING RING (2)	x		x	x	x	x		x	x	x
11	1 7 7 0 2 6	DIAL SHAFT WASHER	x		x	x	x	x		x	x	x
12	1 7 7 3 5 2	STITCH REGULATING DIAL SHAFT			x	x	x			x	x	x
13	1 7 7 3 5 3	STITCH REGULATING DIAL SHAFT	x					x				
14	1 7 7 0 2 9	STEEL BALL	x	x				x	x			
15	1 7 7 0 3 0	NEEDLE POSITION NOTCHED SPRING	x	x				x	x			
16	1 7 6 7 2 5	CONTROL FRAME MOUNTING SCREW (2)	x	x	x	x	x	x	x	x	x	x
17	1 7 7 0 3 1	NEEDLE POSITION STOPPER	x	x				x	x			
18	1 7 7 0 3 2	POSITION STOPPER MOUNTING SCREW	x	x				x	x			
19	1 7 7 0 3 3	NOTCHED SPRING MOUNTING SCREW	x	x				x	x			
20	1 7 6 9 0 9	ADJUSTING LEVER RETAINING RING (2)	x	x	x	x	x	x	x	x	x	x
21	1 7 7 3 5 4	DIAL STOPPER (2)	x	x	x	x	x	x	x	x	x	x
22	1 7 7 0 3 5	DIAL STOPPER SPRING WASHER (2)	x	x	x	x	x	x	x	x	x	x
23	1 7 7 0 3 7	CONTROL FRAME BODY		x					x			
24	1 7 7 0 3 6	CONTROL FRAME BODY			x	x	x			x	x	x
25	1 7 7 0 3 8	ZIG-ZAG WIDTH CONTROL PLATE (2)	x	x	x	x	x	x	x	x	x	x
26	1 7 7 0 3 9	CONTROL FRAME BODY	x					x				
27	1 7 7 3 5 5	FRAME ASSEMBLY	x					x				
27	1 7 7 3 5 6	FRAME ASSEMBLY			x	x	x			x	x	x
27	1 7 7 3 5 7	FRAME ASSEMBLY		x					x			
28	1 7 7 0 4 3	CONTROL FRAME SCREW WASHER								x	x	x
28	1 7 7 0 4 4	ZIG-ZAG LINK ASS. MTG. SCREW WASHER									x	x
29	1 7 6 9 2 1	ZIG-ZAG LINK ASSEMBLY MTG. SCREW									x	x

CAM MECHANISM (C)

REF.	SINGER PART #	CAM MECHANISM (C)	3 3 3 3 3					3 3 3 3 3				
			0 0 0 0 0	0 0 0 0 0	0 0 0 0 0	1 1 1 1 1	1 1 1 1 1					
			1	2	3	4	5	1	2	3	4	5
1	1 7 7 0 4 4	FINGER SHAFT ASSEMBLY MOUNTING SCREW	x	x	x	x		x	x	x	x	
2	1 7 6 9 7 4	FINGER SHAFT ASSEMBLY MTG. SCREW WASHER	x	x	x	x		x	x	x	x	
3	1 7 7 0 4 5	FINGER ASSEMBLY	x	x	x	x		x	x	x	x	
4	1 7 6 6 8 9	FINGER SHAFT RETAINING RING	x	x	x	x		x	x	x	x	
5	1 7 7 0 4 6	FINGER SHAFT	x	x	x	x		x	x	x	x	
6	1 7 6 9 4 5	FRAME SHAFT RETAINING RING (2)	x	x	x	x		x	x	x	x	
7	1 7 7 0 4 7	FINGER FRAME SHAFT	x	x	x	x		x	x	x	x	
9	1 7 7 0 4 8	FINGER FRAME	x					x				
10	1 7 7 0 4 9	FINGER FRAME		x	x	x			x	x	x	
11	1 7 7 0 5 0	RELEASE LEVER ADJUSTING SCREW	x	x	x	x		x	x	x	x	
12	1 7 7 0 5 1	RELEASE LEVER ADJUSTING SCREW NUT	x	x	x	x		x	x	x	x	
13	1 7 7 0 5 2	RELEASE LEVER	x	x	x	x		x	x	x	x	
14	1 7 7 0 5 3	Z FINGER ASSEMBLY		x	x	x			x	x	x	
16	1 7 7 0 5 4	Z FINGER FRAME	x	x	x	x		x	x	x	x	
17	1 7 7 0 5 5	Z ADJUSTING ARM	x	x	x	x		x	x	x	x	
18	1 7 6 9 8 3	Z ADJUSTING ARM ADJUSTING SCREW NUT	x	x	x	x		x	x	x	x	
19	1 7 6 9 8 4	Z ADJUSTING ARM ADJUSTING SCREW	x	x	x	x		x	x	x	x	
20	1 7 6 7 4 3	Z ADJUSTING ARM MTG. SCREW WASHER	x	x	x	x		x	x	x	x	
21	1 7 7 0 5 6	Z ADJUSTING ARM MOUNTING SCREW	x	x	x	x		x	x	x	x	
22	1 7 7 0 5 7	Z FINGER FRAME SHAFT	x	x	x	x		x	x	x	x	
23	1 7 7 0 5 8	FINGER SHAFT ASSEMBLY		x	x	x			x	x	x	
23	1 7 7 0 5 9	FINGER SHAFT ASSEMBLY	x					x				
24	1 7 6 7 1 7	ZIG-ZAG CAM ASSEMBLY MOUNTING SCREW (2)	x					x				
25	1 7 6 9 7 4	ZIG-ZAG CAM ASS. MTG. SCREW WASHER	x					x				
26	1 7 7 0 6 0	ZIG-ZAG CAM FRAME	x					x				
27	1 7 6 9 0 9	ZIG-ZAG CAM SHAFT RETAINING RING (2)	x					x				
28	1 7 7 0 6 1	ZIG-ZAG CAM SHAFT WASHER	x					x				
29	1 7 7 0 6 2	ZIG-ZAG CAM	x					x				
30	1 7 7 0 6 3	ZIG-ZAG CAM SHAFT	x					x				
31	1 7 7 0 6 4	ZIG-ZAG CAM SHAFT ASSEMBLY	x					x				
32	1 7 7 0 6 5	ECCENTRIC STUD	x	x	x	x	x	x	x	x	x	x
33	1 7 7 0 6 6	ZIG-ZAG CONNECTING ROD	x	x	x	x	x	x	x	x	x	x
34	1 7 7 0 6 7	ROLLER	x	x	x	x	x	x	x	x	x	x
35	1 7 7 0 6 8	ZIG-ZAG CONNECTING ROD SPRING	x	x	x	x	x	x	x	x	x	x
36	1 7 6 9 4 5	RETAINING RING	x	x	x	x	x	x	x	x	x	x

CAM MECHANISM (C)

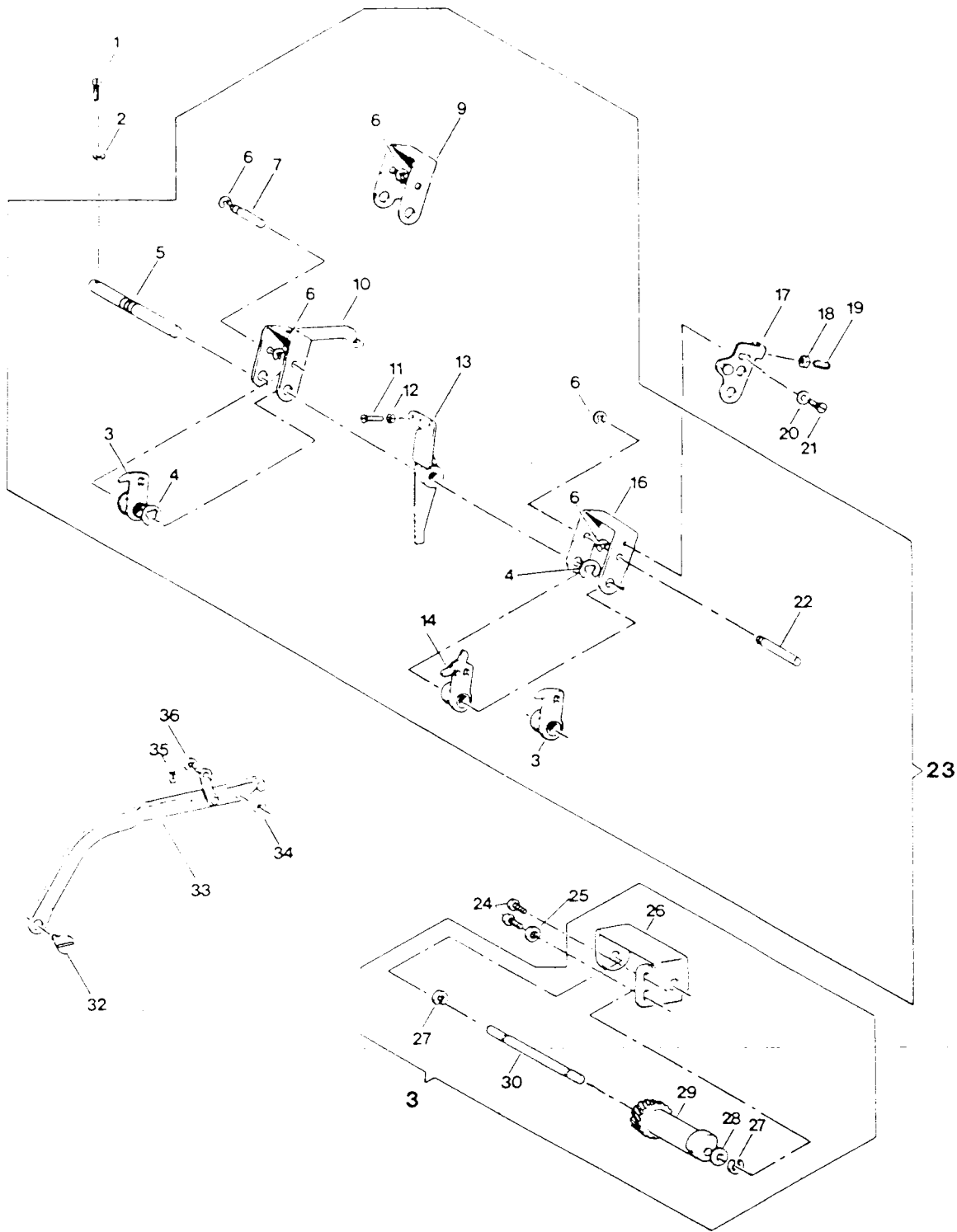

ELECTRICAL EQUIPMENT

REF	SINGER PART #	ELECTRICAL EQUIPMENT	3 3 3 3 3					3 3 3 3 3					
			0	0	0	0	0	0	0	0	0	0	
			0	0	0	0	0	1	1	1	1	1	
			1	2	3	4	5	1	2	3	4	5	
1	177358	SEW LIGHT ASSEMBLY-EUROPE (FREE ARM)							X	X	X	X	X
1	177360	SEW LIGHT ASSEMBLY-AUST/N.Z.(FREE ARM)							X	X	X	X	X
2	176725	SEW LIGHT HOLDER SET SCREW	X	X	X	X	X		X	X	X	X	X
3	177361	SEW LIGHT HOLDER (UL/CSA)	X	X	X	X	X		X	X	X	X	X
4	176717	CORD GUIDE PLATE SET SCREW	X	X	X	X	X		X	X	X	X	X
5	177072	CORD GUIDE PLATE	X	X	X	X	X		X	X	X	X	X
6	177073	SEW LAMP (120V)	X	X	X	X	X		X	X	X	X	X
7	177359	SEW LIGHT ASSEMBLY-UL/CSA (FREE ARM)							X	X	X	X	X
8	177077	MOTOR MTG. BRACKET SCREW WASHER (RIGHT)	X	X	X	X	X						
9	177076	MOTOR MTG. BRACKET SCREW STAR WASHER (RIGHT)	X	X	X	X	X						
10	177075	MOTOR MOUNTING BRACKET SCREW	X	X	X	X	X						
11	177078	MOTOR MOUNTING BRACKET SCREW	X	X	X	X	X						
12	177079	MOTOR MTG. BRACKET STAR WASHER	X	X	X	X	X						
13	177080	MOTOR ADJUSTING STUD	X	X	X	X	X						
14	177081	MOTOR ADJUSTING STUD NUT	X	X	X	X	X						
15	177082	PULLEY (BELT) SET NUT	X	X	X	X	X		X	X	X	X	X
16	177083	PULLEY (BELT)	X	X	X	X	X		X	X	X	X	X
17	177084	PULLEY SET SCREW	X	X	X	X	X		X	X	X	X	X
18	177085	RECEPTACLE PLUG HOUSING SET SCREW (2)	X	X	X	X	X						
19	177986	MOTOR BELT (FLAT BED)	X	X	X	X	X						
20	177087	MOTOR BELT (FREE ARM)							X	X	X	X	X
21	177109	CORD GUARD (UL/CSA)	X	X	X	X	X		X	X	X	X	X
22	177088	RECEPTACLE PLUG MTG. BRACKET SCREWS (2)	X	X	X	X	X		X	X	X	X	X
23	177089	RECEPTACLE PLUG UPPER HOUSING	X	X	X	X	X						
24	177090	RECEPTACLE PLUG LOWER HOUSING	X	X	X	X	X						
25	177091	RECEPTACLE PLUG MTG. BRACKET							X	X	X	X	X
26	177092	CONTROLLER COMPLETE (120V) (988274090)	X	X	X	X	X		X	X	X	X	X
26	177362	CONTROLLER COMPLETE (EUROPE) (988274051)*	X	X	X	X	X		X	X	X	X	X
26	177363	CONTROLLER COMPLETE (UK) (988274055)	X	X	X	X	X		X	X	X	X	X
26	177364	CONTROLLER COMPLETE (AUSTRALIA) (988274057)	X	X	X	X	X		X	X	X	X	X
27	176732	MOTOR MOUNTING BRACKET (RIGHT) MTG. SCREW (2)							X	X	X	X	X
28	177079	MOTOR MTG. BRACKET SCREW STAR WASHER (2)							X	X	X	X	X
29	176943	MOTOR MTG. BRACKET (RT.) MTG. SCREW WASHER (2)							X	X	X	X	X
30	177093	MOTOR MOUNTING BRACKET (RIGHT)							X	X	X	X	X
31	177094	MOTOR MOUNTING BRACKET (LEFT)	X	X	X	X	X		X	X	X	X	X
32	177095	MOTOR MOUNTING BRACKET (LEFT) WASHER (2)	X	X	X	X	X		X	X	X	X	X
33	177096	MOTOR MTG. BRACKET (LEFT) RETAINING NUT	X	X	X	X	X		X	X	X	X	X
34	177097	MOTOR MTG. BRACKET (LEFT) MTG. SCREW	X	X	X	X	X		X	X	X	X	X
35	177098	MOTOR MTG. BRACKET (LEFT) MTG. SCREW WASHER	X	X	X	X	X		X	X	X	X	X
36	177103000	MOTOR 220V FREE ARM							X	X	X	X	X
36	177103002	MOTOR 240V FREE ARM							X	X	X	X	X
36	177099	MOTOR 120V FREE ARM							X	X	X	X	X
37	177100	RECEPTACLE PLUG RETAINING PLATE	X	X	X	X	X		X	X	X	X	X
38	177101	RECEPTACLE PLUG MTG. BRACKET	X	X	X	X	X						
39	177102	RECEPTACLE PLUG	X	X	X	X	X		X	X	X	X	X
40	177103003	MOTOR 220V FLAT BED	X	X	X	X	X						
40	177103001	MOTOR 240V FLAT BED	X	X	X	X	X						
41	177104	MOTOR MTG. BRACKET SCREW NUT	X	X	X	X	X						
42	177105	CORD GUIDE PLATE	X						X				
43	176975	CORD GUIDE PLATE SCREW	X						X				
44	176976	CORD GUIDE PLATE SCREW NUT	X						X				
45	176717	CORD GUIDE PLATE SCREW	X						X				
46	177106	LAMP (220-240V)	X	X	X	X	X		X	X	X	X	X
47	177107	MOTOR MTG. BRACKET (RIGHT)											

ELECTRICAL EQUIPMENT

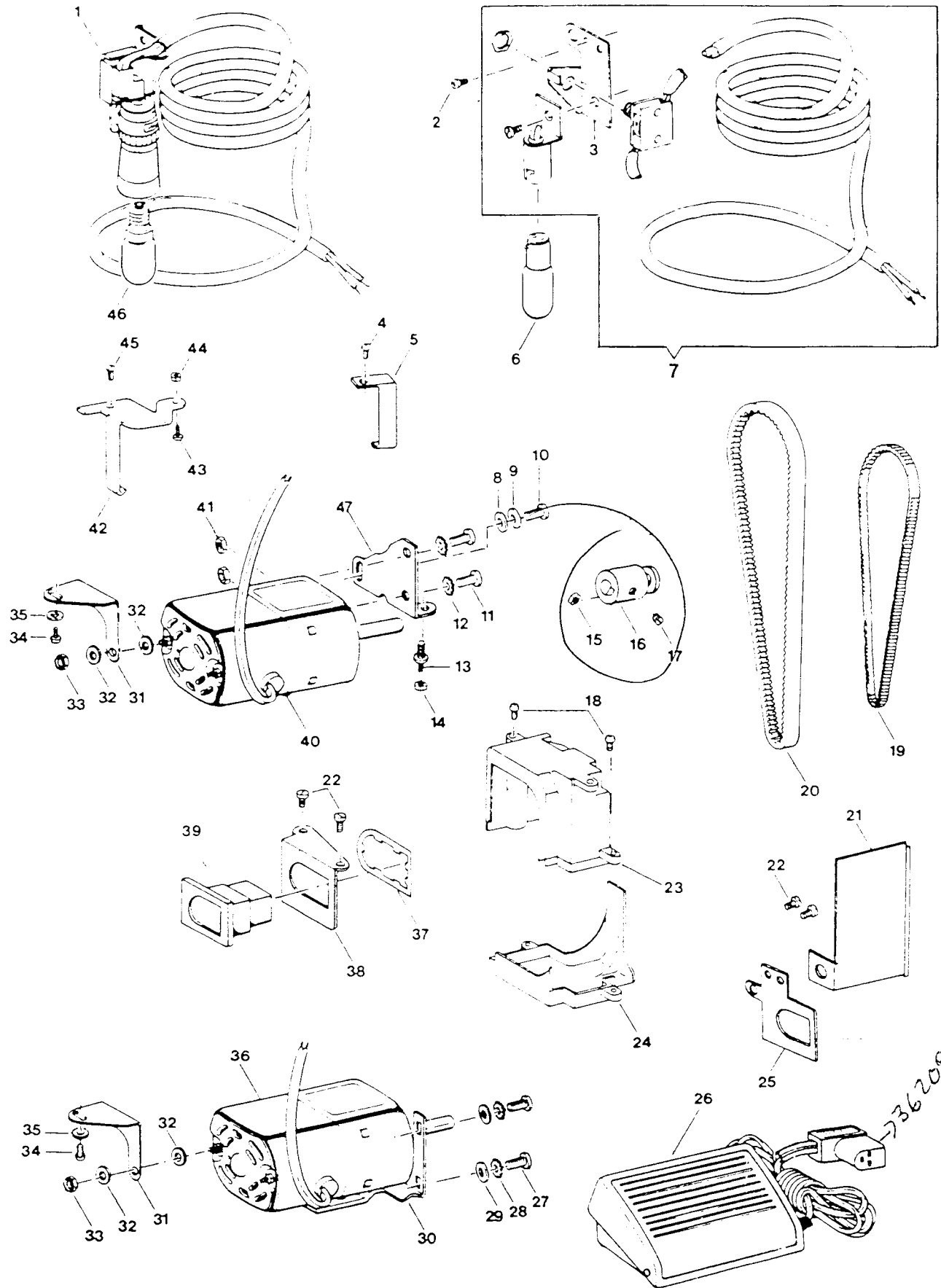

362095-001

OPTIONAL PARTS

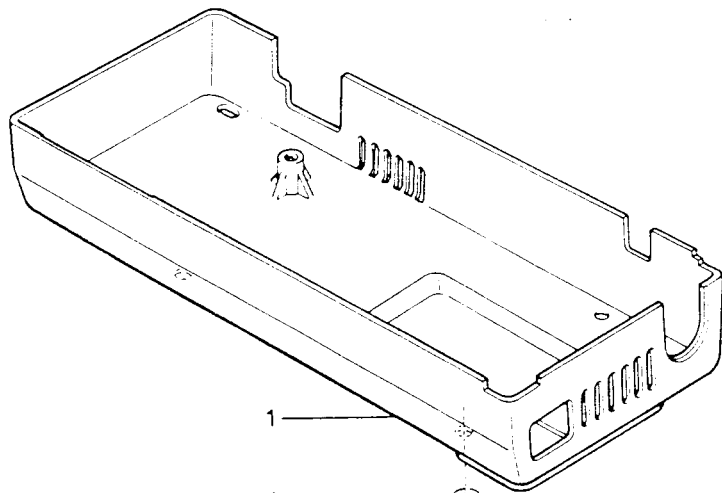

- 1 —
- 4 —
- 2 —
- 5 —
- 3 —

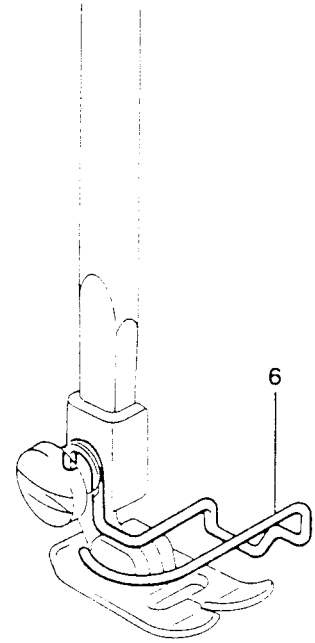

OPTIONAL PARTS

REF.	SINGER PART #	OPTIONAL PARTS	3 3 3 3 3 0 0 0 0 0 0 0 0 0 0 1 2 3 4 5	3 3 3 3 3 0 0 0 0 0 1 1 1 1 1 1 2 3 4 5
1	1 7 7 3 6 5	BOTTOM COVER FOR FLAT BED (OPTIONAL)	x x x x x	
2	1 7 7 1 1 9	RUBBER FEET FOR B/COVER (4)	x x x x x	
3	1 7 7 1 2 0	SCREW FOR B/COVER (4)	x x x x x	
4	1 7 7 1 2 1	WASHER FOR B/COVER (4)	x x x x x	
5	1 7 7 1 2 2	WASHER FOR B/COVER (4)	x x x x x	
6	1 7 7 2 2 1	FINGER GUARD(OPTIONAL)	x x x x x	x x x x x